

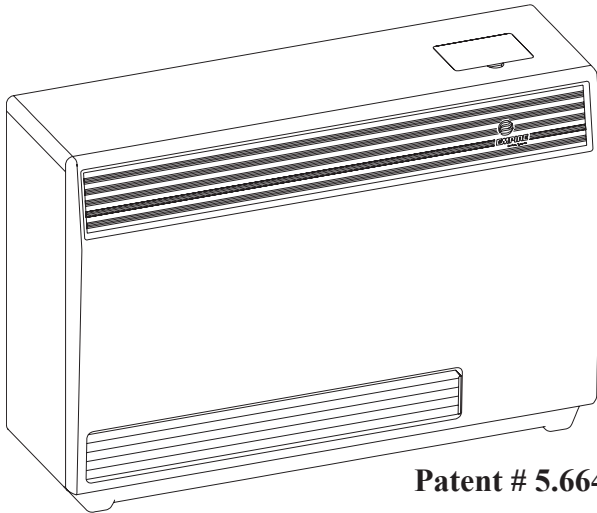

# INSTALLATION INSTRUCTIONS AND OWNER'S MANUAL



Patent # 5.664.555

## FAN TYPE DIRECT VENT WALL FURNACE

For Installation in  
Manufactured (Mobile Home),  
Modular or Residential Homes

MODELS  
DV-20E-5  
DV-40E-5



**Installer:** Leave this manual with the appliance.

**Consumer:** Retain this manual for future reference.

**WARNING:** If the information in these instructions are not followed exactly, a fire or explosion may result causing property damage, personal injury or loss of life.

- Do not store or use gasoline or other flammable vapors and liquids in the vicinity of this or any other appliance.
- **WHAT TO DO IF YOU SMELL GAS**
  - Do not try to light any appliance.
  - Do not touch any electrical switch; do not use any phone in your building.
  - Immediately call your gas supplier from a neighbor's phone. Follow the gas supplier's instructions.
  - If you cannot reach your gas supplier, call the fire department.
- Installation and service must be performed by a qualified installer, service agency or the gas supplier.

This appliance may be installed as an OEM installation in a manufactured home (USA only) or mobile home and must be installed in accordance with the manufacturer's instructions and the Manufactured Home Construction and Safety Standard, Title 24 CFR, Part 3280, in the United States, or the Mobile Home Standard, CAN/CSA Z240 MH Series, in Canada.

This appliance is only for use with the type(s) of gas indicated on the rating plate. A conversion kit is supplied with the appliance.

**WARNING:** If not installed, operated and maintained in accordance with the manufacturer's instructions, this product could expose you to substances in fuel or from fuel combustion which can cause death or serious illness.

# TABLE OF CONTENTS

SECTION	PAGE
Important Safety Information .....	3
Safety Information for Users of LP Gas .....	4
Requirements for Massachusetts .....	5
Introduction.....	6
Specifications .....	6
Gas Supply.....	7
Gas Conversion Instructions .....	8
Clearances.....	9
Furnace Installation.....	9-12
Lighting Instructions .....	13
Wiring .....	14
Maintenance.....	15
Operation and Troubleshooting .....	15-16
How to Order Repair Parts.....	16
Parts List .....	17
Parts View .....	18
Master Parts Distributor List.....	19
Warranty .....	20

# IMPORTANT SAFETY INFORMATION

**THIS IS A HEATING APPLIANCE  
DO NOT OPERATE THIS APPLIANCE WITHOUT FRONT PANEL INSTALLED.**

- Due to high temperatures the appliance should be located out of traffic and away from furniture and draperies.
- Children and adults should be alerted to the hazards of high surface temperatures and should stay away to avoid burns or clothing ignition.
- Young children should be carefully supervised when they are in the same room as the appliance.
- Clothing or other flammable material should not be placed on or near the appliance.
- Any safety screen or guard removed for servicing an appliance must be replaced prior to operating the appliance.
- Keep burner and control compartment clean.
- Vent cap hot while furnace is in operation.
- For manufactured home (USA only) or mobile home or residential installation convertible for use with natural gas and liquefied petroleum gases when provision is made for the simple conversion from one gas to the other.
- Installation and repair should be done by a **QUALIFIED SERVICE PERSON**. The appliance should be inspected before use and at least annually by a qualified service person. More frequent cleaning may be required due to excessive lint from carpeting, bedding materials, etc. It is imperative that control compartments, burners and circulating air passageways of the appliance be kept clean.
- **DO NOT** put anything around the furnace that will obstruct the flow of combustion and ventilation air.
- **DO** keep the appliance area clear and free from combustible material, gasoline and other flammable vapors and liquids.
- **DO** examine venting system periodically and replace damaged parts.
- **DO** make a periodic visual check of burner. Clean and replace damaged parts.
- **DO NOT** use this heater if any part has been under water. Immediately call a qualified service technician to inspect the heater and to replace any part of the control system and any gas control which has been under water.

# SAFETY INFORMATION FOR USERS OF LP-GAS

Propane (LP-Gas) is a flammable gas which can cause fires and explosions. In its natural state, propane is odorless and colorless. You may not know all the following safety precautions which can protect both you and your family from an accident. Read them carefully now, then review them point by point with the members

of your household. Someday when there may not be a minute to lose, everyone's safety will depend on knowing exactly what to do. If, after reading the following information, you feel you still need more information, please contact your gas supplier.

## LP-GAS WARNING ODOR

**If a gas leak happens, you should be able to smell the gas because of the odorant put in the LP-Gas. That's your signal to go into immediate action!**

- Do not operate electric switches, light matches, use your phone. Do not do anything that could ignite the gas.
- Get everyone out of the building, vehicle, trailer, or area. Do that IMMEDIATELY.
- Close all gas tank or cylinder supply valves.
- LP-Gas is heavier than air and may settle in low areas such as basements. When you have reason to suspect a gas leak, keep out of basements and other low areas. Stay out until firefighters declare them to be safe.
- Use your neighbor's phone and call a trained LP-Gas service person and the fire department. Even though you may not continue to smell gas, do not turn on the gas again. Do not re-enter the building, vehicle, trailer, or area.
- **Finally**, let the service man and firefighters check for escaped gas. Have them air out the area before you return. Properly trained LP-Gas service people should repair the leak, then check and relight the gas appliance for you.

## NO ODOR DETECTED - ODOR FADE

Some people cannot smell well. Some people cannot smell the odor of the chemical put into the gas. You must find out if you can smell the odorant in propane. Smoking can decrease your ability to smell. Being around an odor for a time can affect your sensitivity or ability to detect that odor. Sometimes other odors in the area mask the gas odor. People may not smell the gas odor or their minds are on something else. Thinking about smelling a gas odor can make it easier to smell.

The odorant in LP-gas is colorless, and it can fade under some circumstances. For example, if there is an underground leak, the movement of the gas through soil can filter the odorant. Odorants

in LP-Gas also are subject to oxidation. This fading can occur if there is rust inside the storage tank or in iron gas pipes.

The odorant in escaped gas can adsorb or absorb onto or into walls, masonry and other materials and fabrics in a room. That will take some of the odorant out of the gas, reducing its odor intensity.

LP-Gas may stratify in a closed area, and the odor intensity could vary at different levels. Since it is heavier than air, there may be more odor at lower levels. Always be sensitive to the slightest gas odor. If you detect any odor, treat it as a serious leak. Immediately go into action as instructed earlier.

## SOME POINTS TO REMEMBER

- Learn to recognize the odor of LP-gas. Your local LP-Gas Dealer can give you a "Scratch and Sniff" pamphlet. Use it to find out what the propane odor smells like. If you suspect that your LP-Gas has a weak or abnormal odor, call your LP-Gas Dealer.
- If you are not qualified, do not light pilot lights, perform service, or make adjustments to appliances on the LP-Gas system. If you are qualified, consciously think about the odor of LP-Gas prior to and while lighting pilot lights or performing service or making adjustments.
- Sometimes a basement or a closed-up house has a musty smell that can cover up the LP-Gas odor. Do not try to light pilot lights, perform service, or make adjustments in an area where the conditions are such that you may not detect the odor if there has been a leak of LP-Gas.
- Odor fade, due to oxidation by rust or adsorption on walls of new cylinders and tanks, is possible. Therefore, people should be particularly alert and careful when new tanks or cylinders are placed in service. Odor fade can occur in new tanks, or
- reinstalled old tanks, if they are filled and allowed to set too long before refilling. Cylinders and tanks which have been out of service for a time may develop internal rust which will cause odor fade. If such conditions are suspected to exist, a periodic sniff test of the gas is advisable. If you have any question about the gas odor, call your LP-gas dealer. A periodic sniff test of the LP-gas is a good safety measure under any condition.
- If, at any time, you do not smell the LP-Gas odorant and you think you should, assume you have a leak. Then take the same immediate action recommended above for the occasion when you do detect the odorized LP-Gas.
- If you experience a complete "gas out," (the container is under no vapor pressure), turn the tank valve off immediately. If the container valve is left on, the container may draw in some air through openings such as pilot light orifices. If this occurs, some new internal rusting could occur. If the valve is left open, then treat the container as a new tank. Always be sure your container is under vapor pressure by turning it off at the container before it goes completely empty or having it refilled before it is completely empty.

# REQUIREMENTS FOR MASSACHUSETTS

For all side wall horizontally vented gas fueled equipment installed in every dwelling, building or structure used in whole or in part for residential purposes, including those owned or operated by the Commonwealth and where the side wall exhaust vent termination is less than seven (7) feet above finished grade in the area of the venting, including but not limited to decks and porches, the following requirements shall be satisfied:

1. **INSTALLATION OF CARBON MONOXIDE DETECTORS.** At the time of installation of the side wall horizontal vented gas fueled equipment, the installing plumber or gasfitter shall observe that a hard wired carbon monoxide detector with an alarm and battery back-up is installed on the floor level where the gas equipment is to be installed. In addition, the installing plumber or gasfitter shall observe that a battery operated or hard wired carbon monoxide detector with an alarm is installed on each additional level of the dwelling, building or structure served by the side wall horizontal vented gas fueled equipment. It shall be the responsibility of the property owner to secure the services of qualified licensed professionals for the installation of hard wired carbon monoxide detectors
  - a. In the event that the side wall horizontally vented gas fueled equipment is installed in a crawl space or an attic, the hard wired carbon monoxide detector with alarm and battery back-up may be installed on the next adjacent floor level.
  - b. In the event that the requirements of this subdivision can not be met at the time of completion of installation, the owner shall have a period of thirty (30) days to comply with the above requirements; provided, however, that during said thirty (30) day period, a battery operated carbon monoxide detector with an alarm shall be installed.
2. **APPROVED CARBON MONOXIDE DETECTORS.** Each carbon monoxide detector as required in accordance with the above provisions shall comply with NFPA 720 and be ANSI/UL 2034 listed and IAS certified.
3. **SIGNAGE.** A metal or plastic identification plate shall be permanently mounted to the exterior of the building at a minimum height of eight (8) feet above grade directly in line with the exhaust vent terminal for the horizontally vented gas fueled heating appliance or equipment. The sign shall read, in print size no less than one-half (1/2) inch in size, **“GAS VENT DIRECTLY BELOW. KEEP CLEAR OF ALL OBSTRUCTIONS”**.
4. **INSPECTION.** The state or local gas inspector of the side wall horizontally vented gas fueled equipment shall not approve the installation unless, upon inspection, the inspector observes carbon monoxide detectors and signage installed in accordance with the provisions of 248 CMR 5.08(2)(a) 1 through 4.
  - (b) **EXEMPTIONS:** The following equipment is exempt from 248 CMR 5.08(2)(a)1 through 4:
    1. The equipment listed in Chapter 10 entitled “Equipment Not Required To Be Vented” in the most current edition of NFPA 54 as adopted by the Board; and
    2. Product Approved side wall horizontally vented gas fueled equipment installed in a room or structure separate from the dwelling, building or structure used in whole or in part for residential purposes.
  - (c) **MANUFACTURER REQUIREMENTS - GAS EQUIPMENT VENTING SYSTEM PROVIDED.** When the manufacturer of Product Approved side wall horizontally vented gas equipment provides a venting system design or venting system components with the equipment, the instructions provided by the manufacturer for installation of the equipment and the venting system shall include:
    1. Detailed instructions for the installation of the venting system design or the venting system components; and
    2. A complete parts list for the venting system design or venting system.
  - (e) A copy of all installation instructions for all Product Approved side wall horizontally vented gas fueled equipment, all venting instructions, all parts lists for venting instructions, and/or all venting design instructions shall remain with the appliance or equipment at the completion of the installation.

# INTRODUCTION

## Introduction

Always consult your local Building Department regarding regulations, codes or ordinances which apply to the installation of a direct vent wall furnace.

## Instructions to Installer

1. Installer must leave instruction manual with owner after installation.
2. Installer must have owner fill out and mail warranty card supplied with furnace.
3. Installer should show owner how to start and operate furnace and thermostat.
4. Installer must locate unit near a grounded wall receptacle for 115VAC power and must provide gas supply and vent the unit properly for safe operation.

### Warning:

**Any change to this furnace or its control can be dangerous. This is a heating appliance and any panel, door or guard removed for servicing an appliance must be replaced prior to operating the appliance.**

## General Information

This series is design certified in accordance with American National Standard/CSA Standard Z21.86 and CSA 2.32 by the Canadian Standards Association as a Fan Type Direct Vent Wall Furnace to be installed according to these instructions.

**Any alteration of the original design, installed other than as shown in these instructions or use with a type of gas not shown on the rating plate is the responsibility of the person and company making the change.**

## Important

All correspondence should refer to complete Model Number, Serial Number and type of gas.

**Notice:** During initial firing of this unit, oil from the heat exchanger may bake out and smoke may occur. To prevent triggering of smoke alarms, ventilate the room in which the unit is installed.

## Installation in Residential Garages

Gas utilization equipment in residential garages shall be installed so that all burners and burner ignition devices are located not less than 18" (457mm) above the floor.

Such equipment shall be located, or protected, so it is not subject

to physical damage by a moving vehicle.

## Qualified Installing Agency

Installation and replacement of gas piping, gas utilization equipment or accessories and repair and servicing of equipment shall be performed only by a qualified agency. The term "qualified agency" means any individual, firm, corporation or company which either in person or through a representative is engaged in and is responsible for (a) the installation or replacement of gas piping or (b) the connection, installation, repair or servicing of equipment, who is experienced in such work, familiar with all precautions required and has complied with all the requirements of the authority having jurisdiction.

**State of Massachusetts:** The installation must be made by a licensed plumber or gas fitter in the Commonwealth of Massachusetts.

The installation must conform with local codes, or in the absence of local codes, the National Fuel Gas Code, ANSI Z223.1/NFPA 54 or Natural Gas and Propane Installation Code, CSA B149.1.

\*Available from the American National Standards Institute, Inc., 11 West 42nd St., New York, NY 10036.

A manufactured home (USA only) or mobile home OEM installation must conform with the Manufactured Home Construction and Safety Standard, Title 24 CFR, Part 3280, or, when such a standard is not applicable, the Standard for Manufactured Home Installations, ANSI Z225.1, or Standard for Gas Equipped Recreational Vehicles and Mobile Housing, CSA Z240.4.

## High Altitudes

For altitudes/elevations above 2,000 feet (610m), input ratings should be reduced at the rate of 4 percent for each 1,000 feet (305m) above sea level, this may be accomplished by reducing manifold pressure. The maximum allowable reduction in manifold pressure for Natural gas shall be from 3.5" w.c. (.872kPa) to 2.8" w.c. (.697kPa). The maximum allowable reduction in manifold pressure for Propane (LP) gas shall be from 10.0" w.c. (2.49kPa) to 8.0" w.c. (1.99kPa). For Canadian high altitude applications, this appliance is suitable for installation at elevations between 0 feet (0m) and 4,500 feet (1,372m) without change.

# SPECIFICATIONS

Model	DV-20E	DV-40E
Input BTU/HR (KW/H)	20,000 (5.9)	40,000 (11.7)
Height	26" (660mm)	26" (660mm)
Width	37" (940mm)	37" (940mm)
Depth with Shroud	15 3/4" (400mm)	15 3/4" (400mm)
Gas Inlet (Pipe)	1/2" (13mm)	1/2" (13mm)
Electrical - Unit as a 5' (1.5m) 3 pronged cordset for connection to an approved 115 VAC 60HZ minimum AMPs - 5A wall receptacle.		

Accessories	
Extended Vent Terminal For walls up to 32" (813mm)	DVT-2
Intake/Exhaust Extension Kit 54" (1371mm) Vent Kit with 2 Elbows	DVE-1
54" (1371mm) Vent Kit (straight) for Extended Vent Runs	DVE-2 (use with DVE-1)
Floor Pad	DVP-1



# GAS SUPPLY

Consult the current National Fuel Gas Code, ANSI Z223.1 CAN/CGA-B149 (.1 or .2) installation code.

### Recommended Gas Pipe Diameter

Pipe Length	Schedule 40 Pipe Inside Diameter		Tubing, Type L Outside Diameter	
	Nat.	L.P.	Nat.	L.P.
0-10 feet 0-3 meters	1/2"	3/8"	1/2"	3/8"
10-40 feet 4-12 meters	1/2"	1/2"	5/8"	1/2"
40-100 feet 13-30 meters	1/2"	1/2"	3/4"	1/2"
100-150 feet 31-46 meters	3/4"	1/2"	7/8"	3/4"

**Note:** Never use plastic pipe. Check to confirm whether your local codes allow copper tubing or galvanized.

**Note:** Since some municipalities have additional local codes, it is always best to consult your local authority and installation code.

The use of the following gas connectors is recommended:

- ANS Z21.24 Appliance Connectors of Corrugated Metal Tubing and Fittings
- ANS Z21.45 Assembled Flexible Appliance Connectors of Other Than All-Metal Construction

The above connectors may be used if acceptable by the authority having jurisdiction. The state of Massachusetts requires that a flexible appliance connector cannot exceed three feet in length.

A manual main gas cock should be located in the vicinity of the unit. Where none exists, or where its size or location is not adequate, contact your local authorized installer for installation or relocation.

Compounds used on threaded joints of gas piping shall be resistant to the action of liquefied petroleum gases. The gas lines must be checked for leaks by the installer. This should be done with a soap solution watching for bubbles on all exposed connections, and if unexposed, a pressure test should be made.

**Never use an exposed flame to check for leaks. Appliance must be disconnected from piping at inlet of control valve and pipe capped or plugged for pressure test. Never pressure test with appliance connected; control valve will sustain damage!**

A gas valve and ground joint union should be installed in the gas line upstream of the gas control to aid in servicing. It is required by the National Fuel Gas Code that a drip line be installed near the gas inlet. This should consist of a vertical length of pipe tee connected into the gas line that is capped on the bottom in which condensation and foreign particles may collect.

### Pressure Testing of the Gas Supply System

1. To check the inlet pressure to the gas valve, a 1/8" (3mm) N.P.T. plugged tapping, accessible for test gauge connection, must be placed immediately upstream of the gas supply connection to the appliance.
2. The appliance and its individual shutoff valve must be disconnected from the gas supply piping system during any pressure testing of that system at test pressures in excess of 1/2 psig (3.5 kPa).
3. The appliance must be isolated from the gas supply piping system by closing its individual manual shutoff valve during any pressure testing of the gas supply piping system at test pressures equal to or less than 1/2 psig (3.5 kPa).

**Attention! If one of the procedures results in pressures in excess of 1/2 psig (14" w.c.) (3.5 kPa) on the fireplace gas valve, it will result in a hazardous condition.**

### Checking Manifold Pressure

Both Propane and Natural gas valves have a built-in pressure regulator in the gas valve. Natural gas models will have a manifold pressure of approximately 3.5" w.c. (.872kPa) at the valve outlet with the inlet pressure to the valve from a minimum of 5.0" w.c. (1.245kPa) for the purpose of input adjustment to a maximum of 10.5" w.c. (2.614kPa) Propane gas models will have a manifold pressure approximately 10.0" w.c. (2.49kPa) at the valve outlet with the inlet pressure to the valve from a minimum of 11.0" w.c. (2.739kPa) for the purpose of input adjustment to a maximum of 13.0" w.c. (3.237kPa).

A 1/8" (3mm) N.P.T. plugged tapping, accessible for test gauge connection, is located on the outlet side of the gas control.

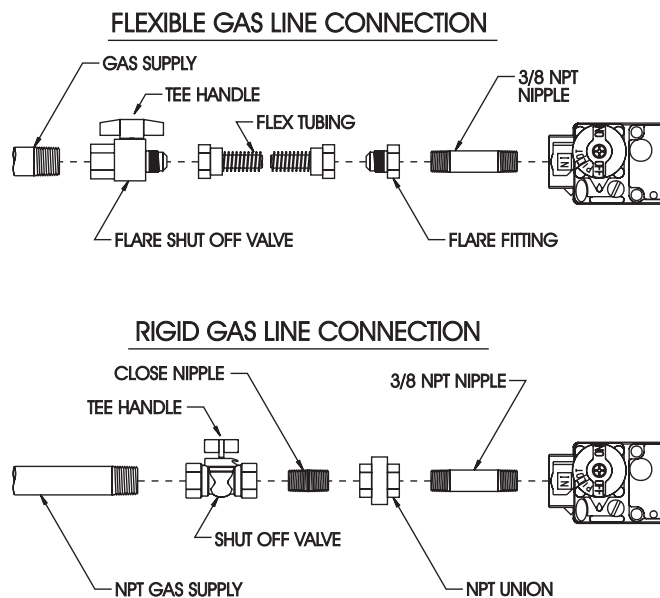

Figure 1

### Installing a New Main Gas Cock

Each appliance should have its own manual gas cock.

# GAS CONVERSION INSTRUCTIONS

**Warning: Conversion must be done by a qualified service technician. Main burner orifice(s) and new gas conversion label are provided in conversion kit attached to manifold pipe.**

## CONVERSION INSTRUCTIONS FROM (LP) PROPANE GAS TO NATURAL GAS

1. Make sure gas supply to furnace is off prior to conversion and disconnect electrical power to unit.
2. Open brass union located between the gas valve and burner box. Remove the 4 mounting screws securing manifold plate to the burner box. Remove the top 2 screws holding the burner box top in place and then remove the 1 screw holding the end of the manifold pipe in place. Grasp union and remove manifold pipe.
3. Remove (1) LP gas main burner orifice marked 55 for DV-20E or (2) LP gas main burner orifices marked 55 for DV-40E located in the manifold pipe and replace with (1) Natural gas main burner orifice marked 44 for DV-20E or (2) Natural gas main burner orifices marked 44 for DV-40E supplied in conversion kit.
4. Replace manifold pipe being sure to locate orifice(s) in the end of the burner. Secure the manifold and top burner box cover in place using the screws earlier removed. Reconnect the brass union.
5. Remove the vinyl cap and unscrew the gas control convertible regulator and reverse to Natural gas side and screw back into place. The red LP ring will be up just under the vinyl cap. Reattach vinyl cap. Refer to figure illustrating the gas valve.
6. Place LP gas main burner orifice(s) in conversion kit. Attach conversion kit to manifold pipe. Attach new label to unit nameplate indicating that the unit was converted to Natural gas.
7. Turn on gas supply to furnace and check all gas connections for leaks with soap solution, watching for bubbles on all gas connections.
8. Turn on electrical power to unit and turn on furnace to verify proper operation. It may take several tries for ignition to completely purge all the air from the gas line.

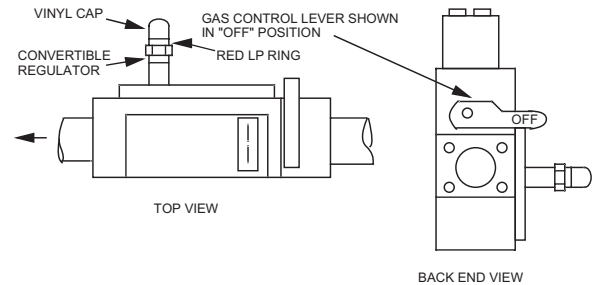

**Warning: Conversion must be done by a qualified service technician. Main burner orifice(s) and new gas conversion label are provided in conversion kit attached to manifold pipe.**

## CONVERSION INSTRUCTIONS FROM NATURAL GAS TO (LP) PROPANE GAS

1. Make sure gas supply to furnace is off prior to conversion and disconnect electrical power to unit.
2. Open brass union located between the gas valve and burner box. Remove the 4 mounting screws securing manifold plate to the burner box. Remove the top 2 screws holding the burner box top in place and then remove the 1 screw holding the end of the manifold pipe in place. Grasp union and remove manifold pipe.
3. Remove (1) Natural gas main burner orifice marked 44 for DV-20E or (2) Natural gas main burner orifices marked 44 for DV-40E located in the manifold pipe and replace with (1) LP gas main burner orifice marked 55 for DV-20E or (2) LP gas main burner orifices marked 55 for DV-40E supplied in conversion kit.
4. Replace manifold pipe being sure to locate orifice(s) in the end of the burner. Secure the manifold and top burner box cover in place using the screws earlier removed. Reconnect the brass union.
5. Remove the vinyl cap and unscrew the gas control convertible regulator and reverse to LP gas side (red ring on regulator) and screw back into place. Reattach vinyl cap. Refer to figure illustrating the gas valve.
6. Place Natural gas main burner orifice(s) in conversion kit. Attach conversion kit to manifold pipe. Attach new label to unit nameplate indicating that the unit was converted to LP gas.
7. Turn on gas supply to furnace and check all gas connections for leaks with soap solution, watching for bubbles on all gas connections.
8. Turn on electrical power to unit and turn on furnace to verify proper operation. It may take several tries for ignition to completely purge all the air from the gas line.

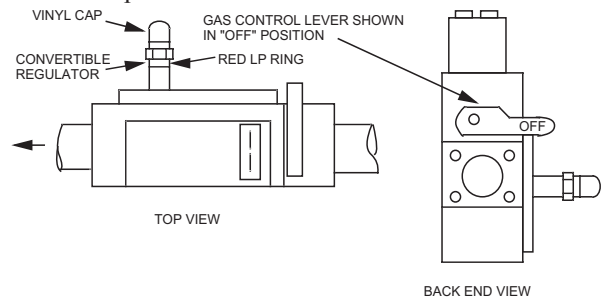



# CLEARANCES

1. Pick a location on a wall with a clear space of 36" (91.4cm) high by 43" (109cm) wide in the room. In selecting a location for installation, it is necessary to provide adequate accessibility clearances for servicing and proper installation. Be sure to locate the unit close enough to a 115 VAC wall receptacle to properly power appliance.
2. Unit is supported by a wall bracket secured to the wall.
3. When facing the front of the furnace the minimum clearances from casing to combustible construction are 10" (254mm) on top, 3" (76mm) on each side, recommend 18" (457mm) on right side for servicing and 0" (0mm) from the floor and 0" (0mm) to rear wall.
4. The black flocked exhaust pipe, contained in DVE-1 Kit or DVE-2 Kit, has zero (0") inches (0mm) clearance to combustibles.
5. The minimum distance from the center of the vent cap to the nearest outside corner or obstruction is 12" (305mm).
6. The minimum wall depth is 2" (51mm) and the maximum is 10" (254mm) [or 32" (813mm) using the extended vent terminal kit accessory]. The use of vent tubes not supplied by the manufacturer may result in unsatisfactory performance.

The vent terminal of a direct vent appliance, with an input of 50,000 BTU (14.6KW) per hour or less shall be located at least 9" (229mm) from any opening through which flue gases could enter a building.

The bottom of the exhaust vent terminal and the air intake shall be located at least 12" (305mm) above grade and must be vented outside.

**WARNING: The nearest point of the vent cap should be a minimum horizontal distant of six (6) feet (1.83m) from any pressure regulator. In case of regulator malfunction, the six (6) feet (1.83m) distance will reduce the chance of gas entering the vent cap.**

## Installation on Rugs and Tile

If this appliance is to be installed directly on carpeting, tile, or other combustible material, other than wood flooring, the appliance shall be installed on a metal or wood panel extending the full width and depth of the appliance.

The base referred to above does not mean the fire-proof base as used on wood stoves. The protection is primarily for rugs that may be extremely thick and light-color tile that can discolor.

# FURNACE INSTALLATION

## Locating Wall Opening (Figures 2, 3 and 4)

The recommended location for this furnace is on an outside wall. (The unit can be located on an inside wall but must be vented using the extended vent kit and should not exceed 15' (4.6m) in exhaust vent length.) Locate wall studs so that wall vent opening will be located between wall studs. The wall studs can be used for attachment of wall mounting bracket. The wall opening required for venting is a 3 1/4" (83mm) minimum diameter opening.

Refer to Figure 2 for positioning the furnace on wall and for locating gas line connection and vent opening. Furnace can sit on the floor and should be secured to the wall through the wall bracket secured to the rear top shroud.

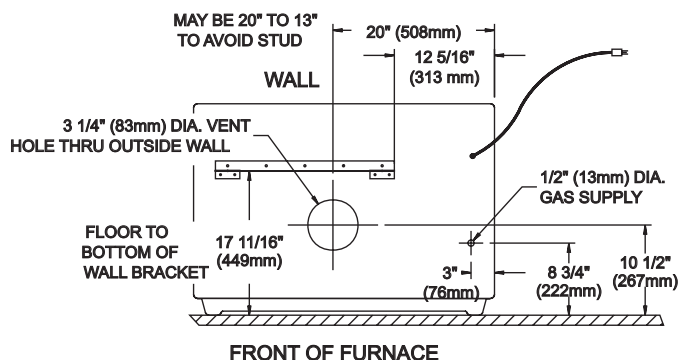

Figure 2

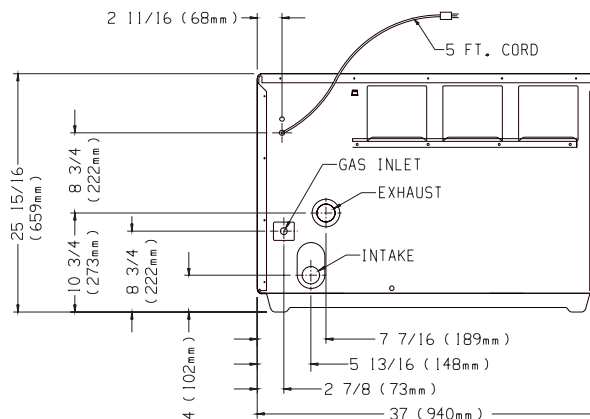

Figure 3

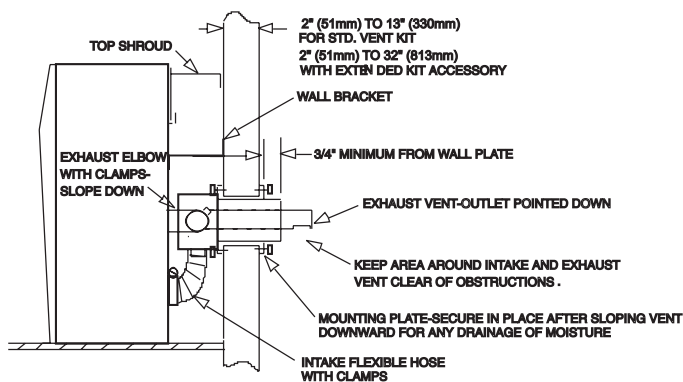

Figure 4

### Installing Wall Bracket (Figures 5 and 6)

After finding a location for the furnace, gas supply and vent, the wall bracket must be positioned and installed. The bracket should be mounted to the wall studs, if possible, or anchored solidly to the wall. Use the (2) 10 x 1" (25mm) hex-head screws or (2) plastic anchors provided. Drill (2) 5/16" (8mm) diameter holes in wall if plastic anchors are used. Attach the two wall mounting brackets to the casing back by using (4) 10 x 1/2" (13mm) hex-head screws provided.

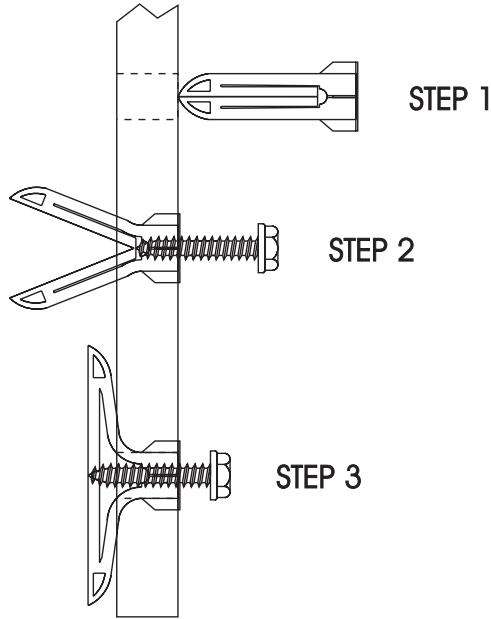

Figure 5

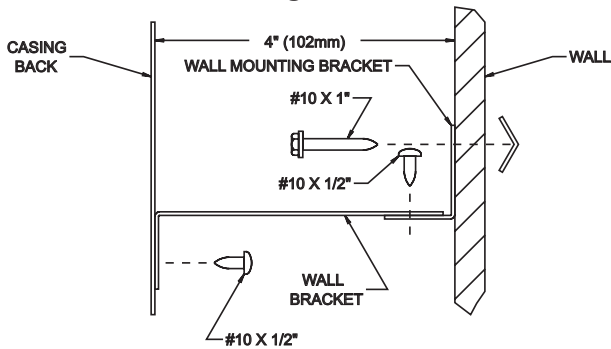

Figure 6

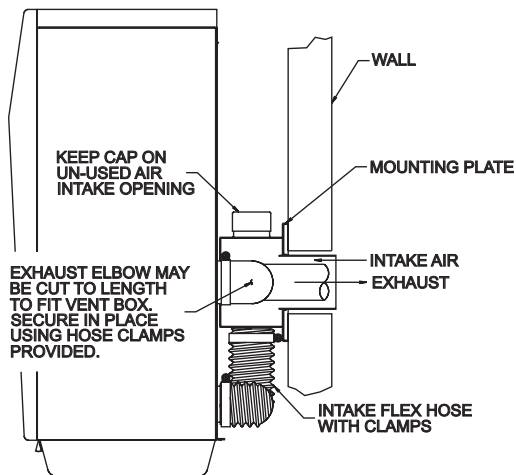

Figure 7

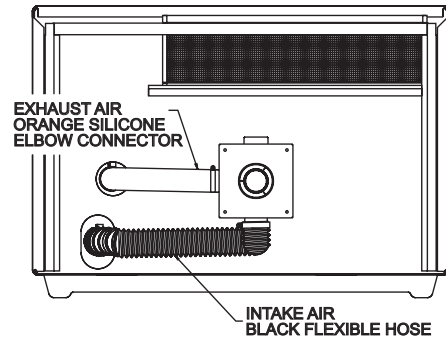

Figure 8

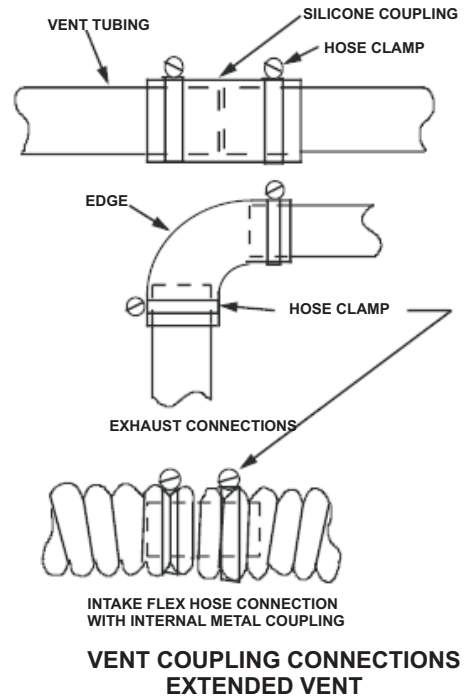

Figure 9

### Venting (Figures 7, 8 and 9)

This unit is vented directly out the back using the concentric vent tube assembly provided. See Figure 2 for vent hole location. This hole location can be conveniently moved closer to unit exhaust outlet tube to avoid wall stud interference if necessary. The orange silicone exhaust elbow would need to be cut to length. Do not locate vent directly behind the exhaust outlet. Do not use the orange silicone elbow for extended vent runs where the possibility of flue condensate exists unless the run is horizontal and the elbow is sloped downward away from the heater. See Figure 12 for extended vertical venting.

The vent provided will accommodate walls up to 10" thick and can be cut shorter for thinner walls if desired by using a hacksaw or cut-off saw. Be sure to leave the minimum 3/4" of tube length extending beyond the outside wall plate. Both the inner and outer tube will be cut to the same length as the inner exhaust tube has an extension piece which is added during final outside assembly.

# FURNACE INSTALLATION (continued)

Be sure to deburr the ends with a file after cutting. Installation is easy after cutting the wall opening secure the vent terminal box in place using the (4) 10 x 1" hex-head screws provided. Locate the box so that the middle exhaust tube is directed toward the furnace exhaust outlet opening. See Figure 8. Attach the black 2" flexible inlet air hose to the bottom 2" connector on the vent box using a hose clamp. Secure the other end to the lower inlet air box connector using the hose clamp. Do not kink hose. Attach the long straight end of the 2" orange silicone exhaust elbow to the middle vent terminal tube and rotate the elbow toward the furnace exhaust outlet. Secure the hose to the vent box using a hose clamp. Carefully push the furnace back closer to the wall and secure the exhaust elbow to the 2" exhaust tube exiting the unit. Secure the elbow in place using the last remaining hose clamp. The furnace can now be secured to the wall.

The furnace can be vented with up to a maximum length of 15' (4.6m) including termination vent and using 2 - 90° elbows. Also, the furnace can be vented with up to a maximum length of 10' (3m) including termination vent and using 3 - 90° elbows. For longer vent lengths order the vent kit, Part Number DVE-1 and DVE-2. See Figures 11 and 12 illustrating extended vent run and venting options.

**Note:** If the extended vent kit is used and the exhaust vent pipe is run through a cold space, such as an attic or a garage, the pipe should be insulated using 1/2" (13mm) thick fiberglass insulation or equivalent to keep the flue products warm enough to avoid condensation. Also, slope 1/4" (6mm) per foot (305mm) the vent terminal horizontal run downward toward the outside of the house to assure any condensate flow out of vent system. Horizontal vent pipe runs of 5 feet (1.5m) or more in length may accumulate condensation in the exhaust pipe and must, therefore, be sloped downward to drain any condensate out of the end vent terminal. Use straps or other suitable supports spaced every 5 feet (1.5m) to adequately hold pipe. Be sure to avoid any low spots or sags in pipe run. Be sure all connections are tight using the hose clamps as shown in Figure 9, "Vent Coupling Connections."

For wall depths thicker than 10" (254mm) order the extended vent terminal kit which will cover walls to 32" (813mm) thickness. The vent pipes must be cut to length to assemble for desired wall thickness.

For extended venting, it is also acceptable to use 2" (51mm) diameter PVC or ABS pipe for the **combustion air intake supply** piping **only** to the unit. If this is used, the pipe and fittings must conform to ANSI and ASTM Standards D1785 for SCH. 40 PVC, D2665 for PVC-DWV, D2241 for SDR-21 and SDR-26 PVC, D2661 for ABS-DWV and F628 for SCH. 40 ABS. Pipe cement and primer must be used and conform to ASTM Standard D2564 for PVC or D2235 for ABS. **This PVC or ABS pipe must not be used for the exhaust vent pipe run.**

Note: Type SDR pipe is not approved for use in Canada.

For new construction installation, the intake and exhaust vent can be run inside a wall, a vertical or horizontal distance prior to exiting the wall. This can be done but not the preferred method of installation due to the inability to perform periodic inspection of

the vent system. In doing this, it is important to securely seal the vent system and slope all horizontal runs downward 1/4" (6mm) per foot (305mm) toward the vent terminal outside to drain out any condensate. It is also necessary to adequately support both the exhaust and intake and to center the exhaust pipe in the wall.

Be sure to consult local codes prior to installation to verify allowable procedures.

## Installation of Shroud

To complete inside installation, secure furnace to the wall bracket by attaching the two wall mounting brackets to the wall bracket by using (2) 10 x 1/2" (13mm) hex-head screws provided (See Figures 4 and 6). To attach the right shroud and left shroud to the casing back, the 3/4" wide flange on the shroud must be positioned toward the casing side. When positioned correctly, the (6) louvers on the shroud will be facing up and the knock-out on the shroud will be facing down. Attach the right shroud and left shroud to the casing back with (3) 10x1/2" hex-head screws supplied in hardware package, for each shroud. Attach top shroud to right shroud and left shroud with (4) Phillips-head screws, supplied in hardware package. Insert air filter into top shroud.

**Attention:** If the right shroud and left shroud are installed incorrectly, with the 3/4" wide flanges facing inward, the top shroud will not be able to be installed onto the side shrouds. The top shroud will appear to be 2 inches, too narrow.

## Vent Terminal (Figure 10)

Place the 6 3/8" x 6 3/8" (162mm x 162mm) black foam, wall plate gasket within the mounting plate. The 4 3/4" (121mm) diameter hole in the black foam gasket will allow for installation of the concentric vent tube assembly. Slide the outside mounting plate into place on the concentric vent tube assembly. The outside mounting plate should seal against the face of the building and be secured in place using (4) 10 x 1" hex-head screws. Be sure to caulk and seal around the pipe on the exterior using high temperature exterior grade, silicone caulk rated at 204°C/400°F. Wipe some silicone sealant on the 2" (51mm) exhaust pipe extension. The end cap can be pushed into place on the exhaust outlet tube.

**Attention:** The opening on the bottom of the end cap must be positioned toward the ground. The opening on the bottom cannot be pivoted to the right or left, it must be centered toward the ground.

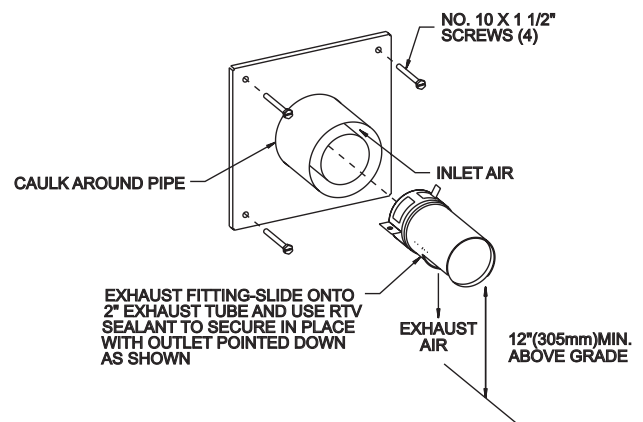

Figure 10

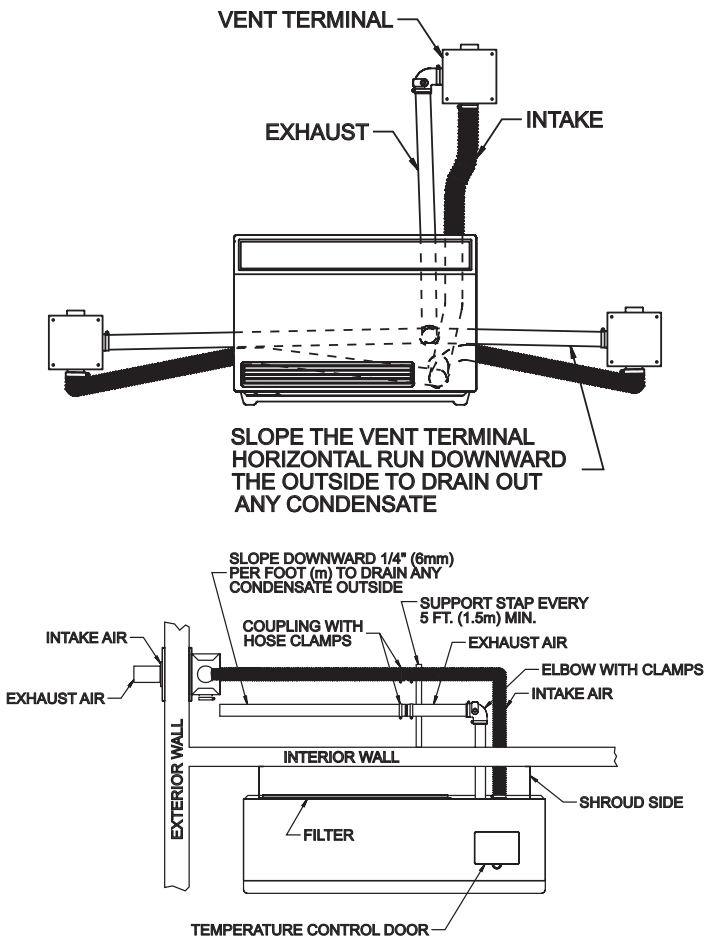

Figure 11

### Condensate Removal (Figures 11 and 12)

The condensate drain kit is used in conjunction with DVE and DVE-2, intake/exhaust extension kits. The condensate drain kit is required whenever there is a vertical vent run, in a heated room [10 ft. (3m) or more for DV-40E or 6 ft. (1.8m) or more for DV-20E], in the intake/exhaust venting.

Whenever a vertical vent run, in a heated room [10 ft. (3m) or more for DV-40E or 6 ft. (1.8m) or more for DV-20E] and a horizontal vent run are combined, you must purchase the optional condensate drain kit, part number DV-1108. If the vertical vent run lengths are less than those required for the condensate drain kit, you can slope the horizontal vent run portion, downward 1/4" (6mm) per foot (.3m) to the outside. However, if local codes prohibit condensate from draining outside and the appliance produces condensate, the horizontal portion of the vent run must slope downward, to the appliance, 1/4" (6mm) per foot (.3m). This will allow any condensate to flow into the condensate drain kit. Do not use the orange silicone elbow supplied with unit to catch condensate. You can route the condensate from the condensate drain kit to an existing drain or into the condensate drain pan located within the appliance.

Whenever a horizontal vent run is used, where local codes allow, you can slope the exhaust pipe downward, to the outside, 1/4" (6mm) per foot (305mm). The downward slope on the exhaust pipe will allow any condensate to flow out of the exhaust pipe. If local codes prohibit condensate from draining to the outside and the appliance produces condensate you must purchase condensate drain kit, part number DV-1108.

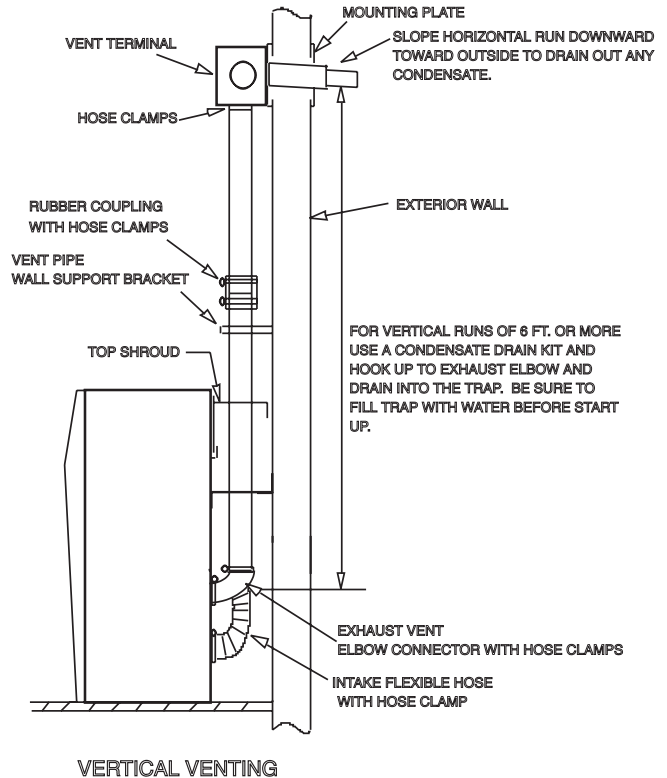

Figure 12

### Reassembly and Resealing Vent-Air Intake System

When vent-air intake system is removed for servicing the furnace, the following steps will assure proper reassembly and resealing of the vent-air intake assembly. Be sure all hose connections and elbow assemblies are re-secured in place using the hose clamps removed. Reattach all screws securing mounting flanges and inspect all connections for a tight fit. Use high temperature silicone caulk rated at 204°C/400°F to reseal the inlet air vent pipe and exhaust air vent pipe to the mounting plate.

# LIGHTING INSTRUCTIONS

## FOR YOUR SAFETY READ BEFORE OPERATING



**WARNING:** If you do not follow these instructions exactly, a fire or explosion may result causing property damage, personal injury or loss of life.

- A. This appliance does not have a pilot. It is equipped with an ignition device which automatically lights the burner. Do not try to light the burner by hand.
- B. BEFORE OPERATING smell all around the appliance area for gas. Be sure to smell next to the floor because some gas is heavier than air and will settle on the floor.
- WHAT TO DO IF YOU SMELL GAS
- Do not try to light any appliance.
  - Do not touch any electrical switch; do not use any phone in your building.
  - Immediately call your gas supplier from a neighbor's phone. Follow the gas supplier's instructions.
- If you cannot reach your gas supplier, call the fire department.
- C. Use only your hand to push in or turn the gas control knob. Never use tools. If the knob will not push in or turn by hand, don't try to repair it; call a qualified service technician. Force or attempted repair may result in a fire or explosion.
- D. Do not use this appliance if any part has been under water. Immediately call a qualified service technician to inspect the appliance and to replace any part of the control system and any gas control which has been under water.

## OPERATING INSTRUCTIONS

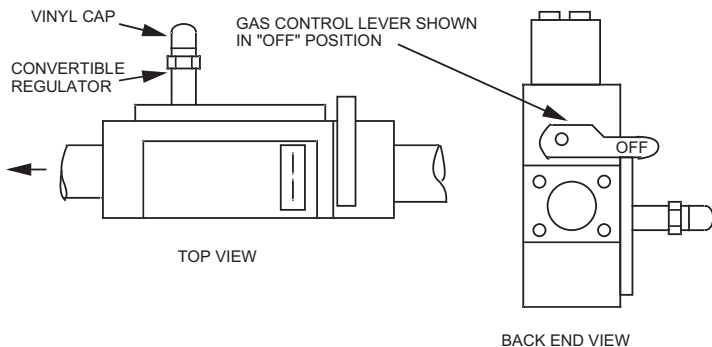
1. **STOP!** Read the safety information above.
2. Set the thermostat to lowest setting.
3. Turn off all electric power to the appliance.
4. This appliance is equipped with an ignition device which automatically lights the burner. Do not try to light the burner by hand.



5. Remove control access panel (front panel).
6. Turn gas control knob clockwise  to "OFF."
7. Wait ten (10) minutes to clear out any gas. Then smell for gas, including near the floor. If you smell gas, STOP! Follow "B" in the safety information above. If you don't smell gas, go to the next step.
8. Turn gas control knob counterclockwise  to "ON".
9. Replace control access panel (front panel).
10. Turn on all electric power to the appliance.
11. Set thermostat to desired setting.
12. If the appliance will not operate, follow the instructions "TO TURN OFF GAS TO APPLIANCE" and call your service technician or gas supplier.

## TO TURN OFF GAS TO APPLIANCE

1. Set the thermostat to lowest setting.
2. Turn off all electric power to the appliance if service is to be performed.
3. Remove control access panel (front panel).
4. Turn gas control knob clockwise  to "OFF." Do not force.
5. Replace control access panel (front panel).



# WIRING

## WIRING DIAGRAM

WARNING: DISCONNECT THE ELECTRIC POWER BEFORE SERVICING

GV = GAS VALVE  
 LS = LIMIT SWITCH  
 FS = FLAME SENSOR  
 XFMR = TRANSFORMER  
 PS = PRESSURE SWITCH  
 IGN = HOT SURFACE IGNITOR  
 ROS = ROLLOUT LIMIT SWITCH

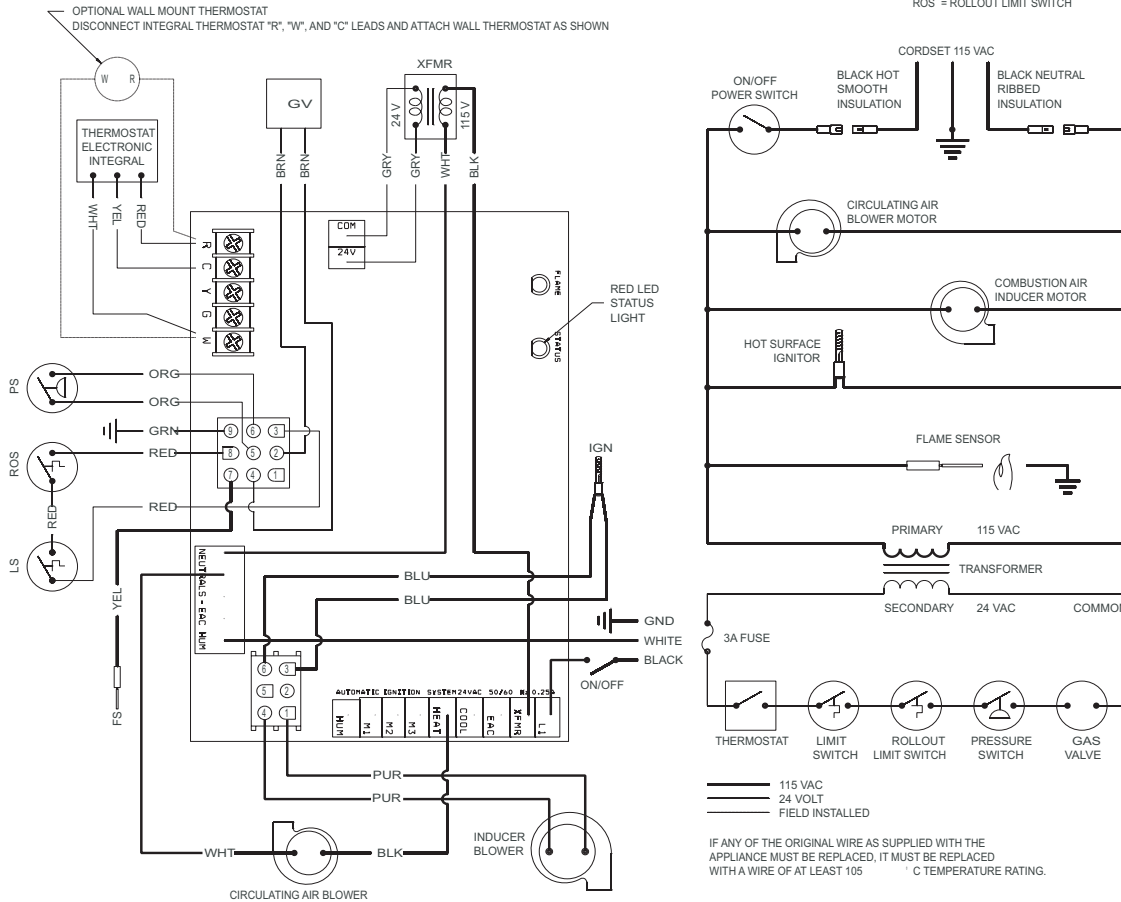

The appliance, when installed, must be electrically grounded in accordance with local codes or, in the absence of local codes, with the National Electrical Code, ANSI/NFPA 70 or Canadian Electrical Code, CSA C22.1, if an external electrical source is utilized. **This appliance is equipped with a three-prong [grounding] plug for your protection against shock hazard and should be plugged directly into a properly grounded three-prong receptacle. Do not cut or remove the grounding prong from this plug.** For an ungrounded receptacle, an adapter, which has two prongs and a wire for grounding, can be purchased, plugged into the ungrounded receptacle and its wire connected to the receptacle mounting screw. With this wire completing the ground, the appliance cord plug can be plugged into the adapter and be electrically grounded.

**CAUTION:** Label all wires prior to disconnection when servicing controls. Wiring errors can cause improper and dangerous operation. Verify proper operation after servicing.

Note: For testing flame sensor circuit use a micro-amp meter in series with sensor. Minimum current should be 1 micro-amp during operation. Be careful as flame sensor is in the 115VAC circuit. If current is below 1 micro-amp, remove sensor, clean with light sandpaper and retest.

Note: This heater is equipped with a remote bulb electronic thermistor control located down low at the back of the furnace. Sometimes due

to field locations different air currents may effect the control sensing of the thermistor. This sensing bulb can be re-located if necessary to provided for better room air sensing and control.

### Replacement of Thermistor with 24 Volt Wall Thermostat

1. If furnace is installed, turn off gas supply and electric supply.
2. Remove casing front.
3. Remove black hose from front nipple on pressure switch.
4. Remove junction box cover (4 screws).
5. Please refer to wiring diagram for removal of the following wires.
6. **Internal Electronic Thermostat/Temperature Control Board**  
**Attention! No 24 volt wall thermostat wires are to be attached to the internal electronic thermostat.**
7. Control Board
  - A. Remove white wire from screw marked W.
  - B. Remove yellow wire from screw marked R.
  - C. Remove red wire from screw marked R.
8. Route (2) wires from any 24 volt wall thermostat through the casing back of furnace to the screws marked W and R on the control board.
9. Replace junction box cover (4 screws).
10. Replace black hose onto front nipple on pressure switch.
11. Replacement of thermistor with 24 volt wall thermostat is completed.

# MAINTENANCE

## Proper Main Burner Flame

The proper main burner flame will be a blue primary (inner) flame with a larger, lighter blue secondary (outer) blue flame.

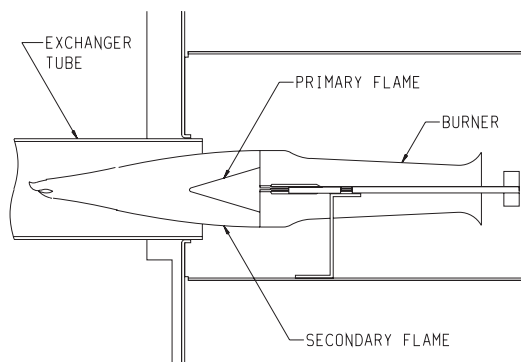

Figure 13

## Cleaning Main Burner(s)

Remove main burner(s) and apply air pressure inside the throat and ports of the main burner(s).

## Removing Main Burner(s)

1. Remove front grill assembly.
2. Remove burner compartment access panel (2 screws).
3. Remove main burner(s) from burner compartment (2 screws per main burner).

## Removing Gas Valve

1. Remove front grill assembly.
2. Disconnect manifold union assembly at gas valve.
3. Remove (2) two 24 volt wires from gas valve. Label wires prior to disconnection from gas valve.
4. Remove gas valve from gas valve bracket.

## Removing Main Burner Orifice(s)

1. Remove front grill assembly.
2. Remove burner compartment access panel (2 screws).
3. Disconnect manifold union assembly.
4. Disconnect manifold union assembly brackets (5 screws).

## Removing Ignitor and Flame Sensor

1. Remove front grill assembly.
2. Remove ignitor from burner compartment (2 screws).
3. Remove flame sensor from burner compartment (1 screw).

## Cleaning Combustion (Exchanger) Assembly

A QUALIFIED SERVICE PERSON should remove the combustion (exchanger) assembly. Apply air pressure to the inside of the combustion (exchanger) assembly in order to clear all passageways.

## Oiling

The blower motor has an oil hole located on each end of the motor. Use #20 motor oil only. It is best to oil the motor several times during the heating season using 2 or 3 drops each time.

# OPERATION AND TROUBLESHOOTING

Your new furnace should provide many years of trouble free performance, however, a yearly inspection of the burners, flue passageways and the outlet vent assembly should be done. Be sure all passageways are open and clear of any obstruction, or soot build up. Be sure to shut off all power to the unit while performing this inspection.

Periodically remove the circulating air filter and clean with water to remove all dirt. Shake dry and reinstall in unit.

## System Operation

1. This furnace has an electronic thermostat and control board to monitor the room temperature and then control the furnace operation to provide the best comfort and performance from a heating appliance. To operate unit turn ON/OFF switch to ON and then turn temperature control knob clockwise slowly till furnace turns on. For typical room comfort, the control knob should be pointed toward medium.
2. The furnace control board follows sequence of operation which allows for self diagnosis in the event there is a problem. The control then blinks a status light, a set number of blinks based on what problem has been encountered. When the furnace is on and there is a no fault condition, the red LED is on. On a typical call for heat by the integral thermostat 24 VAC is applied to the W terminal on the board. The inducer blower circuit is energized and the inducer blower comes on for 15 seconds pre-purging out any gas and closing the pressure switch.

3. The hot surface ignitor is energized and after a 17 second warm-up, the gas valve circuit is energized, opening the gas valve and igniting the burners. After burning for about 30 seconds, the circulating air blower comes on, delivering warm air to the room. If ignition does not occur, the ignition sequence is repeated again up to 2 more times. (3 trials for ignition-total)
3. After the furnace operates and satisfies the thermostat, the gas valve closes and the circulating air blower continues to run for about 2 minutes and then shuts off. The inducer blower runs for 5 seconds and shuts off.

If for any reason ignition and operation does not occur, the control board will blink the red fault status LED, a sequence code, indicating what to look for as a troubleshooting guide. If the red LED is ON but not blinking check the electronic temperature control to verify its operation. This can be easily done by disconnecting the 3 electronic temperature control leads from the main furnace board and using a pig tail jumper to connect R & W together on the board. If the furnace comes on and runs normally the temperature control board is malfunctioning. If the heater still does not come on, then the main furnace board is malfunctioning. Look for any fault codes below and verify the 3 amp fuse is not blown.

**FURNACE CONTROL BOARD  
DIAGNOSTICS  
FAULT SEQUENCE CODE — TROUBLE SHOOTING GUIDE**

# of Blinks	Fault Condition	Fault Correction
Steady On	Control OK	
1 Flash	Temperature limit switch is open	-Check Circulating Air Blower Inlet or Grill Outlet for Blockage, Inducer Blower/Circulating Air Blower Run to Cool Heat Exchanger and Limit -Check for Flame Roll Out Condition Causing Roll Out Limit Switch on Burner Box to Open -Clean Circulating Air Filter
2 Flashes	Pressure switch is open with inducer on	-Check Heat Exchanger and Flue System, Outlet and Inlet for Restriction -Check Inducer Blower/Wheel for Operation/Airflow -Check Pressure Switch
3 Flashes	Pressure switch is closed with inducer off	-Check Pressure Switch and Replace
4 Flashes	Lockout due to failed ignition	-Check for Broken Ignitor -Check for Bent Ignitor Bracket - Ignitor too far from Burner -Check for Flame Sensor Malfunction/or False Ground -Check Gas Valve -Reset Thermostat
5 flashes	L1/Neutral reversed or voltage not present on L1	-Shut Off Power to Unit and Dis-Connect Cordset Plug from Wall Receptacle. Open Junction Box and Un-Reverse Polarity of Incoming Power Leads
Rapid Flash	Flame sense or internal control fault	-Check Ignitor Operation -Check Flame Sensor for Malfunction or False Grounding -Check Gas Valve -Reset Thermostat

**Note:** If the hot surface ignitor is to be replaced, be sure to disconnect all power to the unit. Be very careful in handling the new ignitor as they are fragile and can be broken easily if hit or dropped.

## HOW TO ORDER REPAIR PARTS

Parts can be ordered only through your **service person or dealer**. For best results, the service person or dealer should order parts through the distributor. Parts can be shipped directly to the **service person/dealer**.

All parts listed in the Parts List have a Part Number. When ordering parts, first obtain the Model Number from the name plate on your equipment. Then determine the Part Number (not the Index Number) and the Description of each part from the following appropriate illustration and list. Be sure to give all this information.

Furnace Model Number \_\_\_\_\_ Part Description \_\_\_\_\_

Furnace Serial Number \_\_\_\_\_ Part Number \_\_\_\_\_

Type of Gas (Propane or Natural) \_\_\_\_\_

Do not order bolts, screws, washers or nuts. They are standard hardware items and can be purchased at any local hardware store.

Shipments contingent upon strikes, fires and all causes beyond our control.

# PARTS LIST

PLEASE NOTE: When ordering parts, it is very important that part number and description of part coincide.

INDEX NO.	PART NO.	DESCRIPTION
1	DV-1378	SHROUD TOP
2	DV-1376	SHROUD SIDE RIGHT
3	R-2521	AIR FILTER
4	DV-1375	FILTER RETAINER
5	DV-1379	WALL MOUNTING BRACKET
6	DV-1048	WALL BRACKET - 2 REQUIRED
7	R-2586	CONTROL DOOR PIN - 2 REQUIRED
8	19676	CONTROL DOOR ASSEMBLY
9	DV-1373	CASING TOP
10	DV-1368	BLOWER HOUSING - 2 REQUIRED
11	R-2584	BLOWER WHEEL - 2 REQUIRED
12	R-2573	BLOWER MOTOR
13	R-2598	MOTOR BASE WASHER - 4 REQUIRED
14	R-1279	LIMIT SWITCH
15	DV-1367	INNER TOP
16	R-2546	CONTROL KNOB
17	R-2522	ON/OFF SWITCH
18	19561	JUNCTION BOX
19	DV-1370	JUNCTION BOX COVER
20	R-1995	TRANSFORMER
21	R-6989	PRESSURE SWITCH
22	R-8140	CONTROL BOARD
23	R-2577A	TEMPERATURE CONTROL BOARD
24	DV-1365	CASING WELDED ASSEMBLY
25	R-1468	STRAIN RELIEF BUSHING
26	R-2099	CORD SET
27	DV-1371	INNER END
28	DV-1372	CASING SIDE - 2 REQUIRED
29	15790	COLLECTOR BOX (DV-20E-5 ONLY)
29	15791	COLLECTOR BOX (DV-40E-5 ONLY)
30	R-2519	INDUCER WHEEL
31	DV-1169	INDUCER BLOWER HOUSING
32	R-2523	INDUCER MOTOR
33	15783	EXCHANGER ASSEMBLY (DV-20E)
33	15784	EXCHANGER ASSEMBLY (DV-40E)
34	27523	IGNITOR KIT
37	R-2543	FLAME SENSOR
38	R-2541	BURNER (2 REQUIRED ON DV-40E-5)

INDEX NO.	PART NO.	DESCRIPTION
39	R-2575	FLAME ROLLOUT SWITCH
40	DV-1038	BURNER COMPARTMENT ACCESS PANEL
41	DV-1039	BURNER COMPARTMENT
42	R-3237	GAS VALVE (NAT GAS)
42	R-3238	GAS VALVE (LP GAS)
43	DV-1366	VALVE BRACKET ASSEMBLY
44	DV-1016	MANIFOLD ASSEMBLY (DV-20E-5 ONLY)
44	DV-1013	MANIFOLD ASSEMBLY (DV-40E-5 ONLY)
45	P-88-44	ORIFICE (NAT GAS) - 1 REQUIRED ON DV-20E-5
45	P-88-55	ORIFICE (LPG GAS) - 1 REQUIRED ON DV-20E-5
45	P-88-44	ORIFICE (NAT GAS) - 2 REQUIRED ON DV-40E-5
45	P-88-55	ORIFICE (LPG GAS) - 2 REQUIRED ON DV-40E-5
46	M-148	MANIFOLD GASKET
47	DV-781	OBSERVATION HOLE COVER ASSEMBLY
48	M-155	OBSERVATION HOLE COVER GASKET
49	DV-1040	FRONT SHIELD ASSEMBLY
50	DV-1024	BOTTOM SHIELD
51	DV-1363	FRONT GRILL ASSEMBLY
52	DV-1380	CASING FRONT ASSEMBLY
53	R-2539	HOSE CLAMP - 4 REQUIRED
54	R-3113	INLET HOSE
55	R-3111	OUTLET ELBOW
56	DV-1192	VENT PAN ASSEMBLY
57	R-3114	INLET CAP
58	R-3115	WALL PLATE GASKET - INSIDE
59	R-2587	WALL PLATE GASKET - OUTSIDE
60	DV-1195	WALL PLATE - OUTSIDE
61	DV-1193	TUBE SPACER
62	DV-1194	END CAP ASSEMBLY
63	DV-1377	SHROUD SIDE LEFT
NS	DV-1361	BAFFLE - 1 REQUIRED ON DV-20E-5
NS	DV-1108	Condensate Kit
NS	DV-1132	Elbow Kit
NS	R-8142	WIRE ASSEMBLY - CONTROL BOARD

NS - NOT SHOWN

# PARTS VIEW

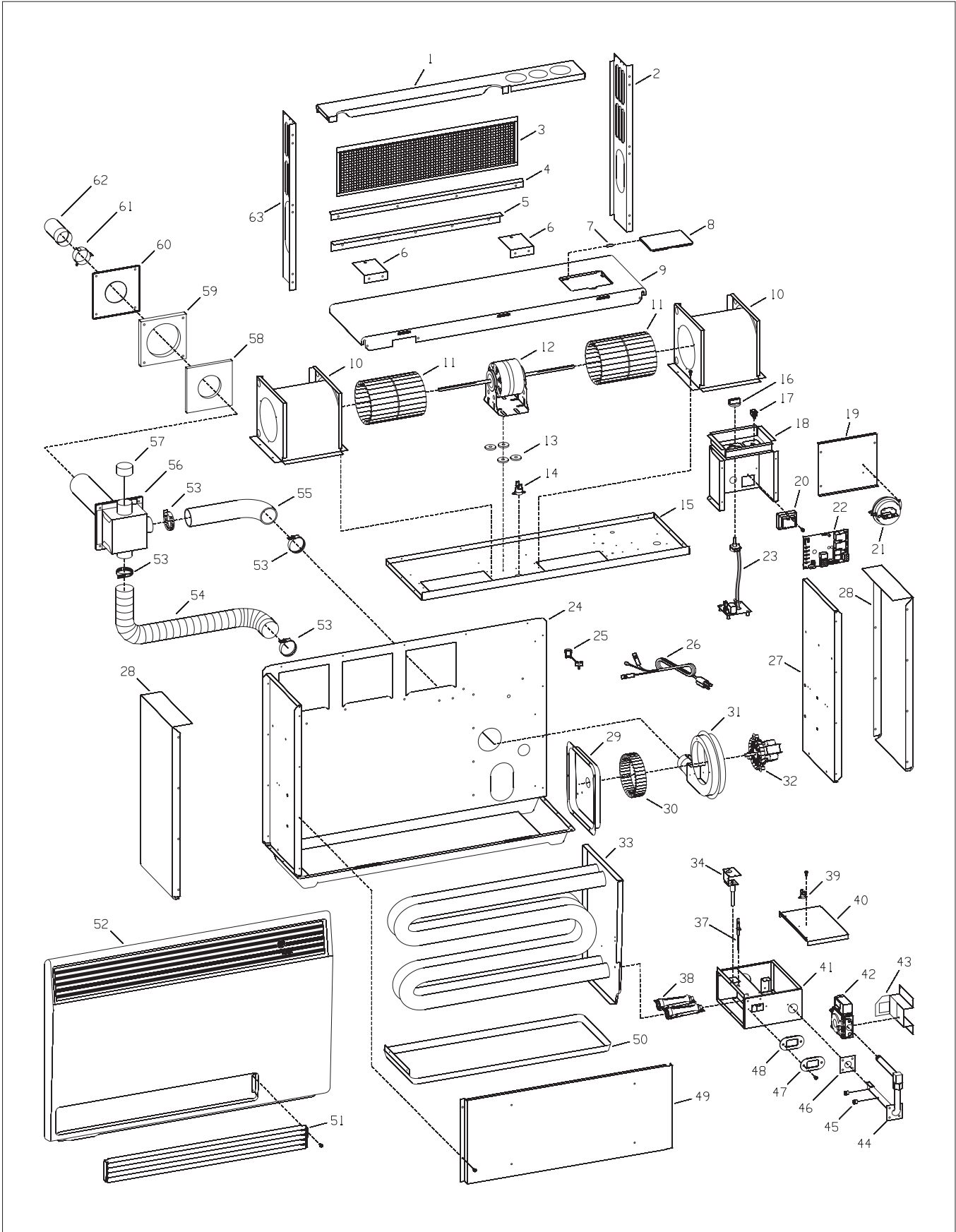



# MASTER PARTS DISTRIBUTOR LIST

To Order Parts Under Warranty, please contact your local Empire dealer. See the dealer locator at [www.empirecomfort.com](http://www.empirecomfort.com). To provide warranty service, your dealer will need your name and address, purchase date and serial number, and the nature of the problem with the unit.

To Order Parts After the Warranty Period, please contact your dealer or one of the Master Parts Distributors listed below. This list changes from time to time. For the current list, please click on the Master Parts button at [www.empirecomfort.com](http://www.empirecomfort.com).

Please note: Master Parts Distributors are independent businesses that stock the most commonly ordered Original Equipment repair parts for Heaters, Grills, and Fireplaces manufactured by Empire Comfort Systems Inc.

## Dey Distributing

1401 Willow Lake Boulevard  
Vadnais Heights, MN 55101

**Phone:** 651-490-9191

**Toll Free:** 800-397-1339

**Website:** [www.deydistributing.com](http://www.deydistributing.com)

**Parts:** Heater, Hearth and Grills

## Victor Division of F. W. Webb Company

200 Locust Street  
Hartford, CT 06114

**Phone:** 860-722-2433

**Toll Free:** 800-243-9360

**Fax:** 860-293-0479

**Toll Free Fax:** 800-274-2004

**Websites:** [www.fwwebb.com](http://www.fwwebb.com) & [www.victormfg.com](http://www.victormfg.com)

**Parts:** Heater, Hearth and Grills

## East Coast Energy Products

10 East Route 36  
West Long Branch, NJ 07764

**Phone:** 732-870-8809

**Toll Free:** 800-755-8809

**Fax:** 732-870-8811

**Website:** [www.eastcoastenergy.com](http://www.eastcoastenergy.com)

**Parts:** Heater, Hearth and Grills

## Able Distributors

2501 North Central Avenue  
Chicago, IL 60639

**Phone:** 773-889-5555

**Toll Free:** 800-880-2253

**Fax:** 773-466-1118

**Website:** [www.abledistributors.com](http://www.abledistributors.com)

**Parts:** Heater

# HOW TO ORDER REPAIR PARTS

## Parts Not Under Warranty

Parts can be ordered through your Service Person, Dealer, or a Master Parts Distributor. See this page for the Master Parts Distributors list. For best results, the **service person or dealer** should order parts through the distributor. Parts can be shipped directly to the **service person/dealer**.

## Warranty Parts

Warranty parts will need a proof of purchase and can be ordered by your Service Person or Dealer. Proof of purchase is **required** for warranty parts.

All parts listed in the Parts List have a Part Number. When ordering parts, first obtain the Model Number and Serial Number from the name plate on your equipment. Then determine the Part Number (**not** the Index Number) and the Description of each part from the following illustration and part list. Be sure to give all this information . . .

Appliance Model Number \_\_\_\_\_ Part Description \_\_\_\_\_

Appliance Serial Number \_\_\_\_\_ Part Number \_\_\_\_\_

Type of Gas (Propane or Natural) \_\_\_\_\_

Do not order bolts, screws, washers or nuts. They are standard hardware items and can be purchased at any local hardware store.

Shipments contingent upon strikes, fires and all causes beyond our control.

# WARRANTY

Empire Comfort Systems Inc. warrants this space heating product to be free from defects at the time of purchase and for the periods specified below. Space heating products must be installed by a qualified technician and must be maintained and operated safely, in accordance with the instructions in the owner's manual. This warranty applies to the original purchaser only and is not transferable. All warranty repairs must be accomplished by a qualified gas appliance technician.

**Limited Lifetime Parts Warranty with a Five-Year Limited Labor Warranty – Combustion Chamber and Heat Exchanger**

*If the combustion chamber or heat exchanger (see parts list) fails because of defective workmanship or material, Empire will repair or replace at Empire's option.*

*Within five years from the date of purchase, Empire will pay reasonable labor to have the defective part repaired or replaced at Empire's option.*

**Limited Five-Year Parts & Labor Warranty – All Other Components (Except Thermostats)**

*Should any part fail because of defective workmanship or material within five years from the date of purchase, Empire will repair or replace at Empire's option.*

*Within five years from the date of purchase, Empire will pay reasonable labor to have that defect repaired at Empire's option.*

**Limited One-Year Parts Warranty – Remote Controls, Thermostats, Accessories, and Parts**

*Should any remote control, thermostat, accessory, or other part fail because of defective workmanship within one year from the date of purchase, Empire will repair or replace at Empire's option.*

**Duties of the Owner**

The appliance must be installed by a qualified installer and operated in accordance with the instructions furnished with the appliance.

A bill of sale, cancelled check, or payment record should be kept to verify purchase date and establish warranty period.

Ready access to the appliance for service

**What Is Not Covered**

Damages that might result from the use, misuse, or improper installation of this appliance.

Travel, diagnostic costs and freight charges on warranted parts to and from the factory.

Claims that do not involve defective workmanship or materials.

Unauthorized service or parts replacements.

Removal and reinstallation cost.

Inoperable due to improper or lack of maintenance.

**How To Get Service**

To make a claim under this warranty, please have your receipt available and contact your installing dealer. Provide the dealer with the model number, serial number, type of gas, and purchase verification. The installing dealer is responsible for providing service and will contact the factory to initiate any warranted parts replacements. Empire will make replacement parts available at the factory. Shipping expenses are not covered.

If, after contacting your Empire dealer, service received has not been satisfactory, contact: Consumer Relations Department, Empire Comfort Systems Inc., PO Box 529, Belleville, Illinois 62222, or send an e-mail to [info@empirecomfort.com](mailto:info@empirecomfort.com) with "Consumer Relations" in the subject line.

**Your Rights Under State Law**

This warranty gives your specific legal rights, and you may also have other rights, which vary from state to state.



Empire Comfort Systems Inc.  
918 Freeburg Ave. Belleville, IL 62220

If you have a general question about our products, please e-mail us at [info@empirecomfort.com](mailto:info@empirecomfort.com).

If you have a service or repair question, please contact your dealer.

[www.empirecomfort.com](http://www.empirecomfort.com)