

INSTRUCTION MANUAL AND OWNERS GUIDE



24/30 Inch
Outdoor Rated
Wall Mount Air Circulators

SPECIFICATIONS	
Volts	120V
Frequency	60Hz
Fan Speeds	3
Cord Length	9 ft.



WFO-24
WFO-30

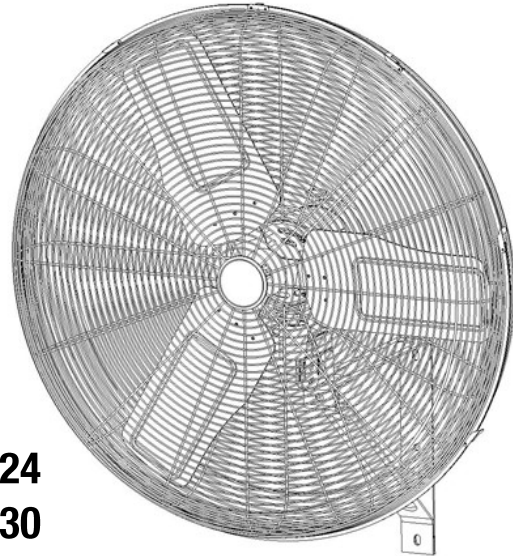

DO NOT RETURN TO STORE

If you experience any difficulties installing or operating this product.
Call us Toll Free at: 1-800-603-5464 (Select Option 2 from the Menu) / 7:00am to 3:30pm PST Mon-Fri
Support at king-electric.com or email us at info@king-electric.com



WARNING



READ CAREFULLY - Use the fan only as described in this manual. Any other use is not recommended and could result in fire, electric shock, and personal injury. Following these instructions will prevent difficulties that might occur during the installation and use of the fan. Please study the instructions first, as they may save considerable time and trouble during use addition to providing important safety information. Make sure to save these instructions for future use.

- WARNING**
1. Read and save these instructions. Do not operate fan unless you have read these instructions.
 2. Unplug the fan before moving it or performing maintenance. Do not touch the fan when your hands are wet.
 3. Those who are not qualified electricians should not disassemble, repair or rebuild the fan.
 4. Unplug the fan when it is not in use.
 5. DO NOT unplug the fan by pulling the cable cord. Unplug by holding the plug and pulling.
 6. DO NOT use the fan when there is damage to the cable cord or plug. If the supply cord is damaged, it has to be replaced by the manufacturer, its service agent or similarly qualified persons.
 7. DO NOT use the fan with extension cord.
 8. DO NOT use the fan close to fires.
 9. DO NOT insert your hand or other objects into the grille or the movable parts.
 10. To reduce the risk of fire or electric shock, do not use this fan with any solid-state speed control device.

- CAUTION**
1. Unplug the fan from the socket and clean it with a soft cloth.
 2. DO NOT immerse the fan.
 3. Fit the guard onto fan before starting up the fan.
 4. This fan is not intended for use by people (including children) with reduced physical, sensory or mental capabilities or lack of experience and knowledge unless they have been given supervision or instruction concerning use of the fan by a person responsible for their safety. Supervise children to ensure they do not play with the fan.

ASSEMBLY INSTRUCTIONS

1. Mark the mounting hole locations by using the holes in the bracket as a guide, then drill the holes.
 - A. For concrete wall installation, after drilling, you would insert the wall anchors and tap them flush with the wall, position the bracket and then screw the two bolts into the anchors, securely attaching the bracket to the wall.
 - B. For wall stud installation, after drilling the smaller diameter pilot hole, position the bracket and screw the two bolts into the wall until they are secured.



CAUTION

The fan is only suitable for concrete wall or direct to stud installation. Do not use for dry wall mounting. Use the mounting accessories shipped with products for wall mounting.



WARNING

This fan is to be mounted with the wall bracket, it **MUST** be mounted and secured on a solid wall that is structurally sound to support the fan and mounting bracket. The wall bracket along with the fan **MUST NOT** be mounted on any surface that is subject to vibration, wobbling, movement or the like. The fan **MUST** be mounted and properly secured to a **STATIONARY** structure.

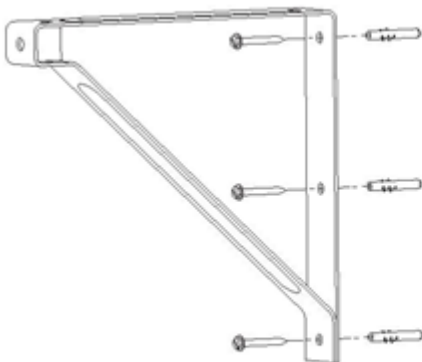

a. concrete wall

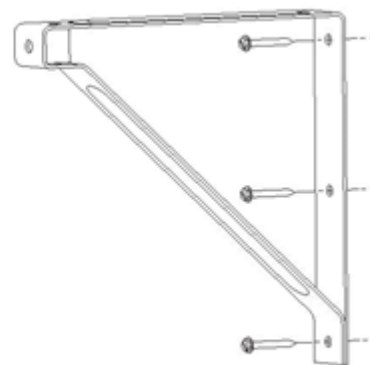

b. wall stud

ASSEMBLY INSTRUCTIONS

2. Remove four sets of hexagonal nuts, spring washers, and flat washers from the motor.
Save them for step 3.

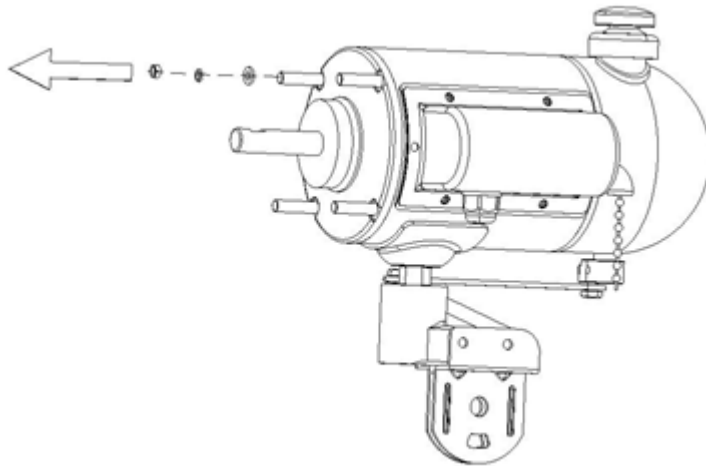

3. Set the rear guard in the proper position and affix it to the motor using the hex nuts, spring washers and flat washers.

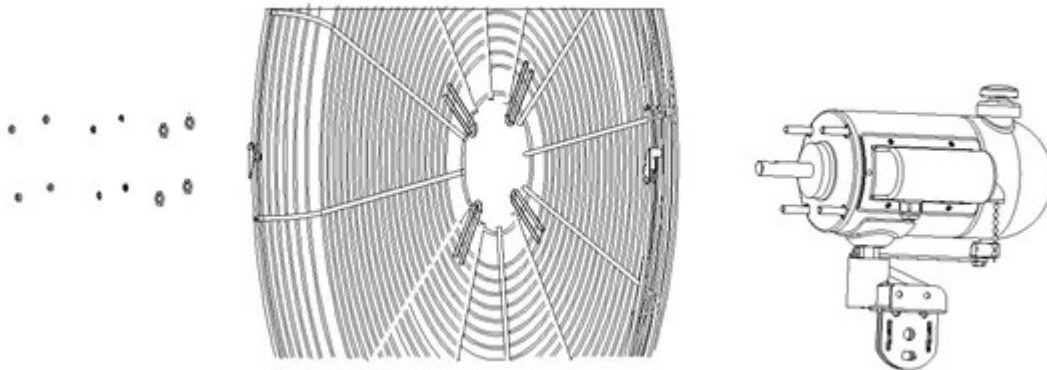

4. Assemble the fan blade onto the motor shaft by tightening the one screw.
Make sure the screws are tightly secured.

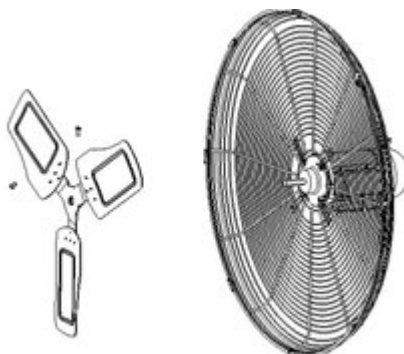

ASSEMBLY INSTRUCTIONS

5. Attach the front guard to the rear guard and secure them together using the clips on the front guard.

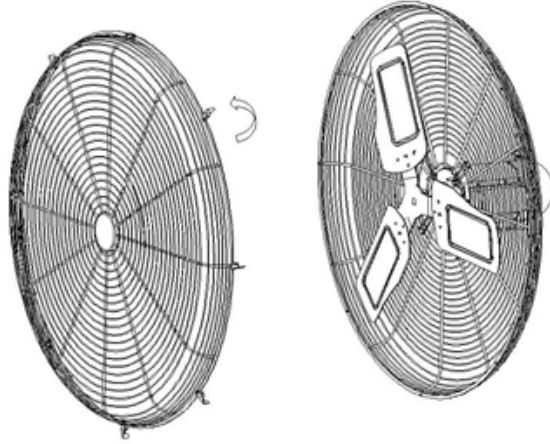

6. Secure the assembly on the front guard and rear guard by tightening the screw, washer and nut at the bottom of the fan guards.

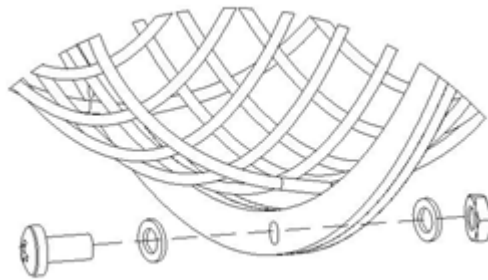

7. **For Motor Bracket Assembly,** Remove the two screws (g) and nuts (h) from the motor frame and retain for future use.

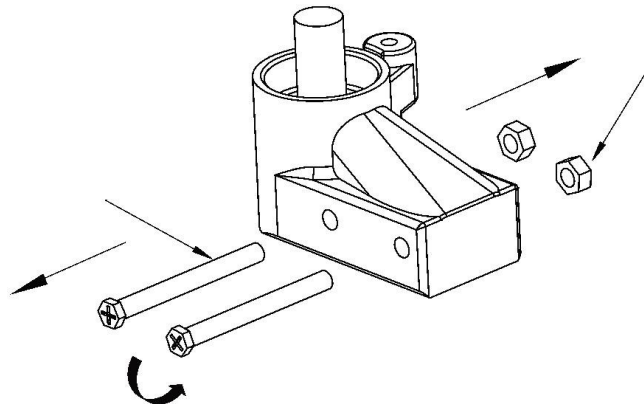

ASSEMBLY INSTRUCTIONS

8. Insert the swivel bracket into motor frame bracket and fasten it with bolt (a), flat washer (b), spring washer (c) and nut (d). Fasten the bolt (f) with the knob (e) for adjusting the tilt angle of the fan or fix the tilt angle of the fan.

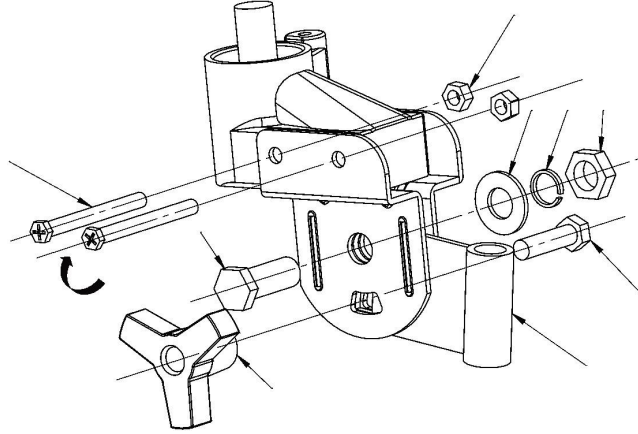

9. Assemble the swivel bracket with wall bracket and fasten with hexagon screw, flat washer, spring washer and nut.

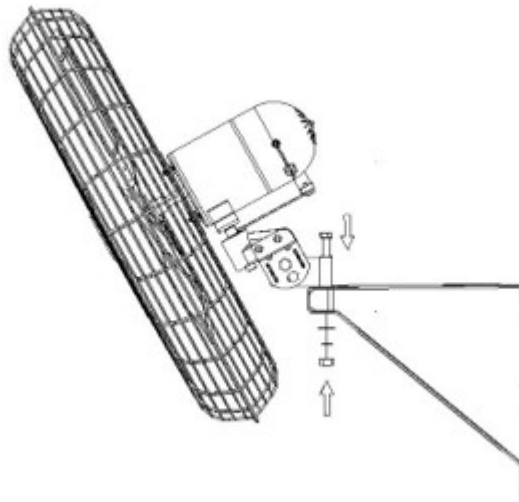

10. Loosen the washer nut (g) and adjust until the fan head is at the desired angle. Tighten the washer nut (g).

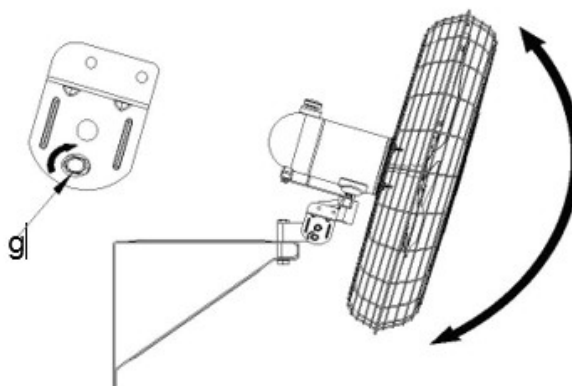

ASSEMBLY INSTRUCTIONS

Secondary Safety Support Cable

Use of secondary safety support cable does not guarantee protection against injury of persons. Mounting of both the air circulator and cable could fail if subject to abuse, neglect or if improperly installed. To avoid personal injury, circulators must be supported anytime angle is adjusted.

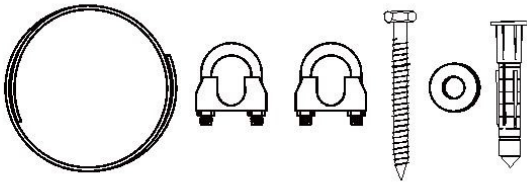

PARTS	SPECIFICATION	QTY
	Ø3*3050	1
	M5*13	2
	ST8*50	1
	Ø8* 24* 52	1
	Ø10*60	1

1. Loop one end of the cable around the large diameter wires of both the front and rear guard as shown below. Attach a cable retainer with the "U" on the tail side of the loop leaving a tail of approximately 1 to 2 inches. Tighten clamp nuts forming a tight loop, 32in. lbs of torque. Make sure the cable does not interfere with the propeller.

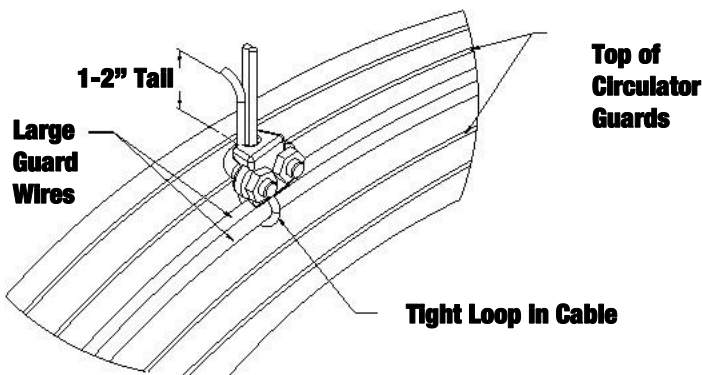

2. Wrap the other end of the cable around a secure building joist, beam, truss or other support near the fan as shown below. Take up all excess slack in the cable. If the fan is an oscillating model and wall mounted, leave enough slack to allow free movement through range of motion.

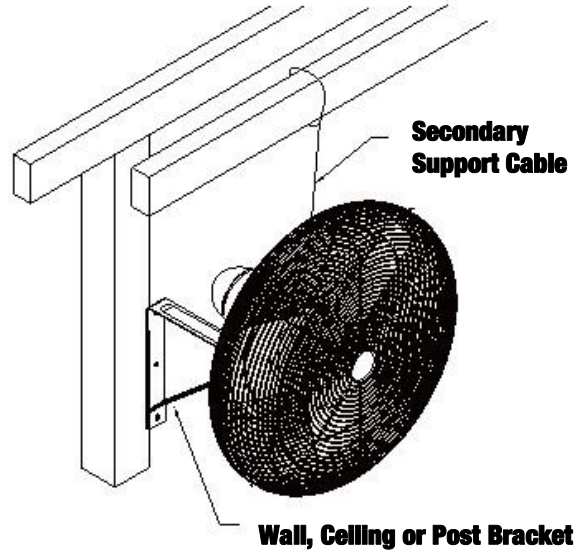

3. Attach the remaining cable retainers as done previously in "step 1". The excess tail should be trimmed to extend 1 to 2 inches past the second clamp.
4. Check the assembly to assure the propeller is free of all obstructions and turns freely.
5. Connect the air circulator to the proper power supply ensuring that it confirms to the electrical rating listed on the circulators motor nameplate.

For Concrete wall installation

1. Drill hole in concrete wall, insert the wall anchor and tap it flush with the wall.
2. Fasten a bolt and a washer through the terminal of secondary safety support cable and insert into the anchor for security.

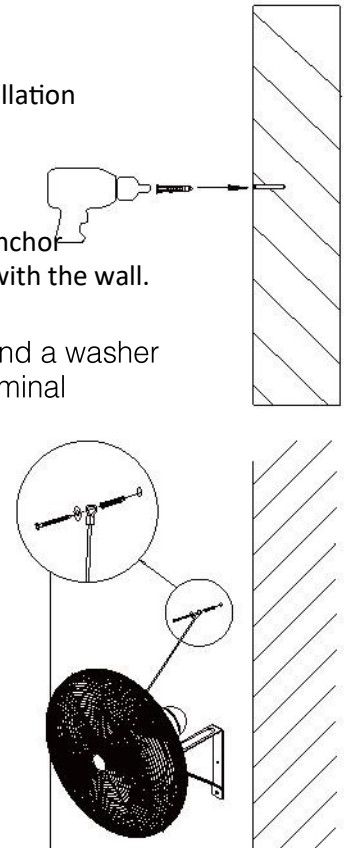

OPERATING INSTRUCTIONS

1. Test GFCI (Ground Fault Circuit Interrupter) plug BEFORE EACH USE.
 Plug GFCI into power outlet. Press RESET button (b).
 Indicator (a) should turn red.
 Press TEST button (c). Indicator (a) should turn off.
 GFCI plug is tripped.
 Press RESET button (b) again for use.
2. Fan is turned ON and the 3 speeds are selected using pull chain switch (e) located at back of motor.
3. Pressing the oscillation knob (d) will allow the fan head to be turned. Pulling up on the oscillation knob (d) will lock the fan head at the desired position.

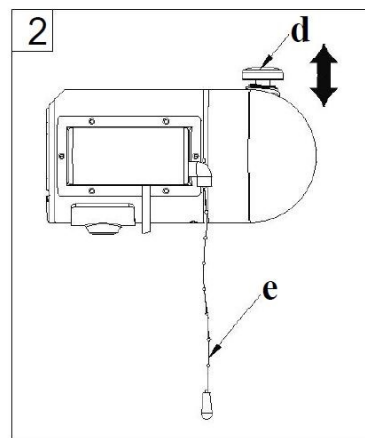
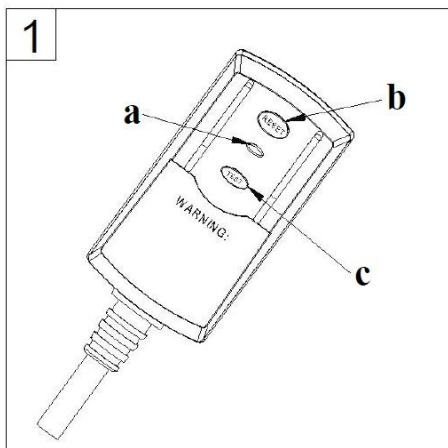

CARE AND MAINTENANCE

Unplug the appliance before cleaning. Don't use any water for cleaning metal surfaces. Slightly moisten a cloth and then wipe off the surfaces of the fan. In order to remove dust from the grill, use a vacuum cleaner or remove the front grill by removing the securing screws on the edge of the grill. After cleaning, remount the grill. After doing this, fasten the screws on the edge of the grill.

1-YEAR LIMITED WARRANTY

The manufacturer warrants this product to be free from manufacturing defects in the material and workmanship under normal use for a period of one year after the date of purchase by the original purchaser. This warranty does not cover transit damages. This warranty does not apply to damages from accident, misuse, alteration of any kind to the fan or where the connected voltage is more than above the nameplate voltage. This warranty does not apply to the finish on any portion of the product. Servicing performed by unauthorized persons shall render the warranty invalid. The warranty is not responsible for damages of any kind, including accident and consequential damages. Some states do not allow the exclusion or limitation of the incidental or consequential damages, so the above exclusion or limitation may not apply to you. This warranty gives you specific legal rights, and you may also have other rights which vary from state to state.