

Models:
TR11, TR11T-B
**Round Termination Cap and
Storm Collar**



These chimney termination caps have been tested for use with specific Hearth & Home Technologies fireplaces and are UL listed as fireplace parts. Refer to the installation instructions supplied with the fireplace for the correct accessories to be used. Check with your local building code agency before you begin installation to ensure compliance with local codes, including the need for permits and follow-up inspections. If you encounter any problems regarding code approvals, or if you need clarification of any of the instructions contained here, contact your local distributor/dealer or visit www.hearthnhome.com.

Note: An arrow (➡) found in the text signifies change in content.

CAUTION



Sharp Edges

- Wear protective gloves and safety glasses during installation.



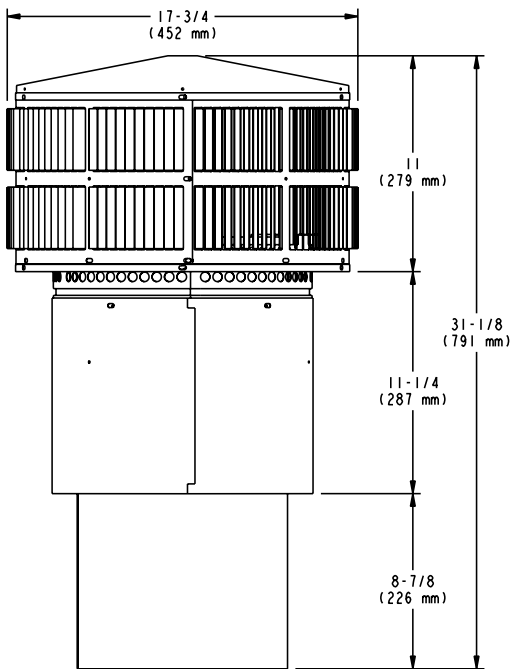

TR11T-B

Description	Qty
Termination Cap	1
Storm Collar	1
Fastener Package	1

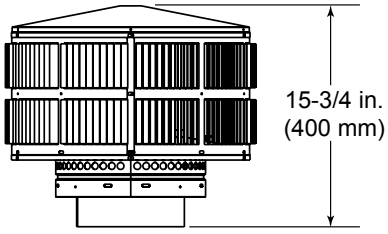

TR11

Note: The chimney must extend at least 3 ft (.91 m) above the highest point where it passes through the roof and at least 2 ft (.61 m) above any portion of the building within 10 ft (3.05 m). These minimum distances comply with national code construction requirements but do not guarantee smoke free operation.

A. TR11 Round Termination Cap

- Install the roof flashing or the chase top. See Table 1 for required dimensions of the chase top if using a shroud.
- Fabricate a chase top as shown in Figure 1.
- The uppermost chimney section must extend 4 in. (102) above the top of the chase top collar to allow for the installation of the TR11 termination cap and the storm collar.

B. Install Chase Top

- You **MUST** use a chase top in a chase installation. Chase tops may be field constructed.
- Include a turndown and drip edge to prevent water from seeping into the chase.
- Include a 2 in. (51 mm) soldered, welded or spun collar around pipe opening to keep water out.
- Provide a 1/8 in. (3 mm) gap around the flue pipe.
- Slope the chase top downward away from the opening.

WARNING! Risk of Fire! DO NOT caulk the pipe to the chase top collar.

- Caulk all seams to prevent leaks.

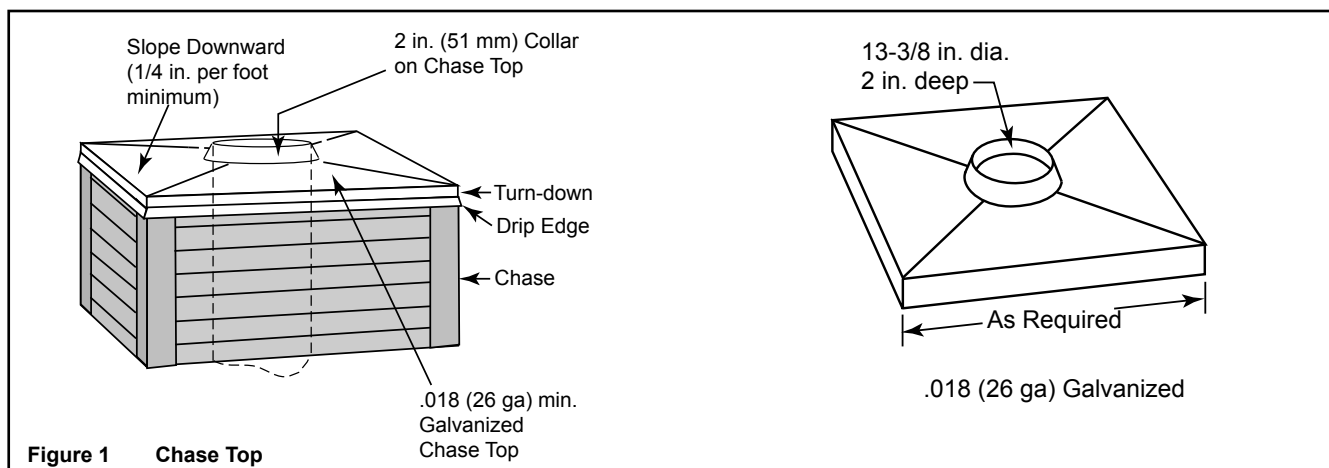

Figure 1 Chase Top

- Install the storm collar over the uppermost chimney section and secure in place with the provided bolt. Caulk the gaps between the chimney and the top of the storm collar to prevent leaks. Any seams along the storm collar must also be sealed.
- Position the round termination cap over the uppermost chimney section and snap-lock it into position.

WARNING! Risk of Fire! The minimum overlap of cap to pipe (as shown in the following illustrations) MUST be met or chimney may separate from cap. Separation allows sparks, heat and embers to escape.

- Caulk the overlap seam of any exposed pipe sections that are located above the roof line to prevent leaks.
- Paint the termination cap with a rust-resistant paint to protect against the effects of corrosion on those parts exposed to the weather.

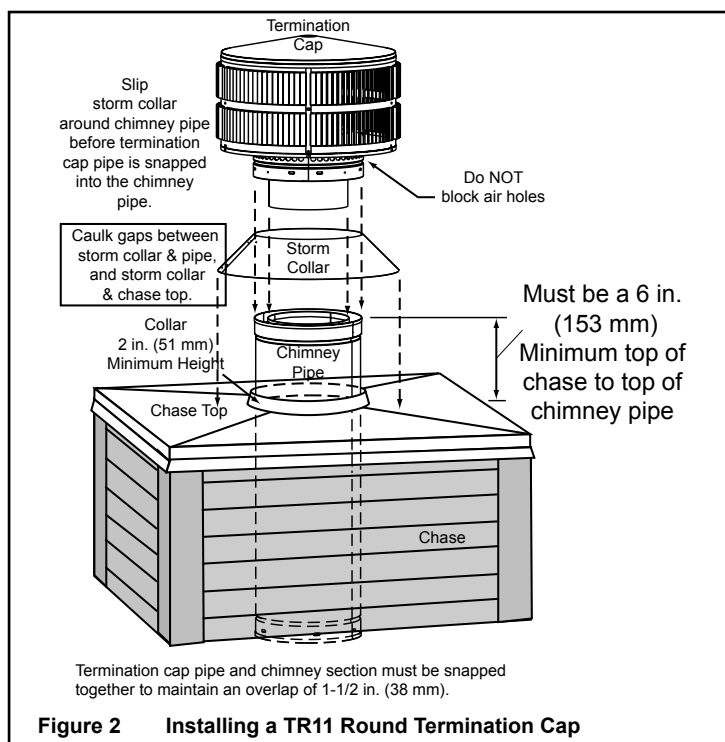

Figure 2 Installing a TR11 Round Termination Cap

Note: If you do not want to snap-lock the round termination cap in place, crush the snap-lock tabs on the termination cap collar flat and attach to the uppermost chimney section with three self-tapping screws.

C. TR11 Telescoping Round Termination Cap

- The uppermost chimney section must terminate no more than 4-3/4 in. (121 mm) below the chase top. See Figure 3 for additional details.
- Position the telescoping round termination cap above the collar of the chase top and lower the cap assembly until the stainless steel telescoping slip section engages 2 in. (51mm) above the top of the chase into the uppermost chimney section. Push the termination cap down until the three support brackets contact with the chase top collar.
- Attach the three support brackets to the chase top collar with the screws provided.
- Wrap the storm collar around the outer slip section. Fasten the ends of the storm collar together with a screw at the bottom and a nut and bolt through the clamp lock at the top. Slide the storm collar down until it contacts the chase top and tighten the clamp lock.
- Caulk the gaps between the outer slip section and the top of the storm collar to prevent leaks. Any seams along the storm collar must also be sealed.

Note: To protect against the effect of corrosion on those parts exposed to the weather, the termination cap can be painted with a rust-resistant paint.

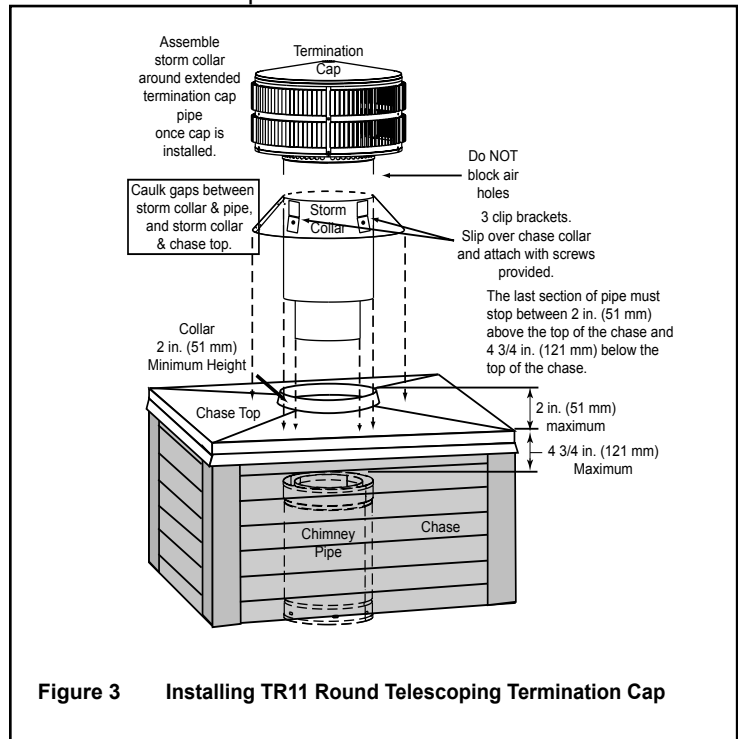

Figure 3 Installing TR11 Round Telescoping Termination Cap

D. Shrouds

- Field Constructed Shrouds
 - Different shroud designs have been tested for Hearth & Home Technologies fireplace systems using the TR11 and TR11T termination caps. These shrouds may be field constructed if the dimensional requirements specified in Table 1 are maintained. Some examples are shown in Figure 4. These shrouds must be constructed from a minimum .018 in. (26 ga) thick aluminized steel. The wire mesh is optional but recommended and must be .018 in. thick minimum aluminized steel with a maximum 1/2 in. (13 mm) mesh opening.
 - The TR-TVK Round Termination Top Vent Kit is available to reduce the minimum sizes required for shrouds. See Table 1.

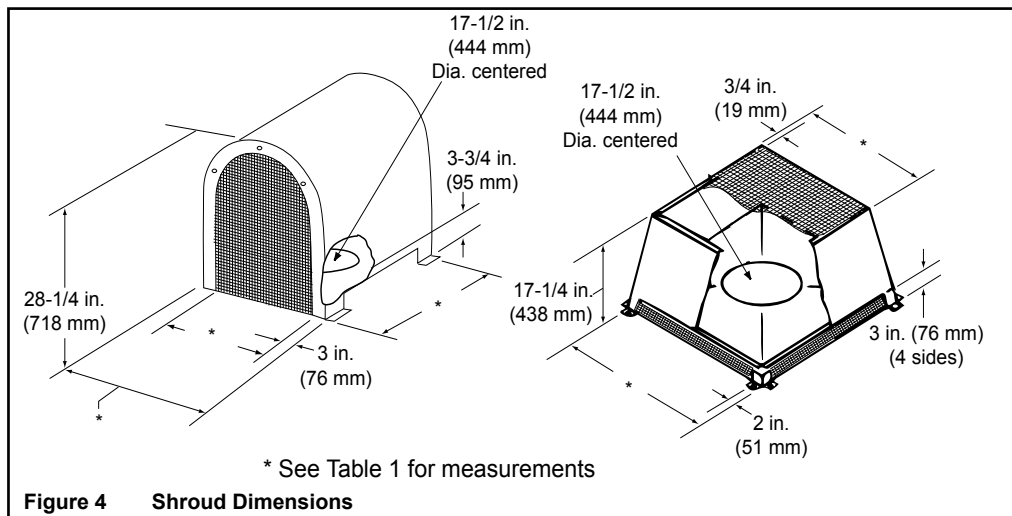

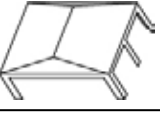

Figure 4 Shroud Dimensions

- Installation of the Shroud
 - Center the hole in the bottom pan (if required) of the shroud over the termination cap and lower the shroud down to the chase top.
 - Be sure to keep the shroud centered over the chimney termination and fasten the shroud to the chase top with screws.
 - Be sure to caulk or seal around the screw heads to prevent leaks.

TABLE 1

Woodburning Termination Cap

Shroud	TS345/T445 (Top Vent)	TR342/TR344 TR442/TR444	TV342 TR342/TR344* TR442/TR444* (* with TR-TVK installed)	TR11/TR11T	TV11/TV11T TR11/TR11T* (* with TR-TVK installed)
	OPEN TOP with solid sides and 3 in. (76 mm) opening at the bottom				
Minimum Base Dimensions	23 in. x 23 in. (584 x 584 mm)	28 x 28 in. (711 x 711 mm) with Radiation Shield	26 x 26 in. (660 x 660 mm)	32 x 32 in. (813 x 813 mm) with Radiation Shield	26 x 26 in. (660 x 660 mm)
Minimum Top Dimensions	20 x 20 in. (508 x 508 mm)	25 x 25 in. (635 x 635 mm)	23 x 23 in. (584 x 584 mm)	29 x 29 in. (737 x 737 mm)	23 x 23 in. (584 x 584 mm)
	MAILBOX STYLE with open ends and 3 in. (76 mm) opening at the bottom of the sides.				
Minimum Base Dimensions	N/A	26.5 x 28 in. (673 x 711 mm) with Radiation Shield	28 x 30 in. (711 x 762 mm)	34 x 34 in. (864 x 864 mm) with Radiation Shield	28 x 30 in. (711 x 762 mm) with Radiation Shield or 34 x 34 in. (864 x 864 mm)
Minimum Height	N/A	28 1/4 in. (718 mm)	27 1/2 in. (699 mm)	28 1/4 in. (718 mm)	27 1/2 in. (699 mm)
	ROOFED STYLE with 12 x 22 in. (264 sq. in.) (305 x 559 mm) opening on each side and 3 in. (76 mm) space between the radiation shield and chase top.				
Minimum Base Dimensions	N/A	27 x 27 in. (686 x 686 mm) with Radiation Shield	27 x 27 in. (686 x 686 mm) with Radiation Shield	34 x 34 in. (864 x 864 mm) with Radiation Shield	34 x 34 in. (864 x 864 mm) with Radiation Shield
Minimum Height	N/A	23 in. (584 mm)	23 in. (584 mm)	23 in. (584 mm)	23 in. (584 mm)
Minimum Height is measured from the bottom of the termination cap: Minimum height is established with the bottom of the termination cap 7 in. (178 mm) above the chase top. Minimum height must increase accordingly for any height above 7 in. (178 mm).					
All dimensions are INSIDE dimensions.					