



AMERICAN FLAME

Electronic Safety Pilot System for Vented Gas Logs

Models:

AFVK-SP-SPLIT

AFVK-SP-HL-SPLIT

AFVK-SP-MHL-SPLIT

IF YOU CANNOT READ OR UNDERSTAND THESE INSTALLATION INSTRUCTIONS DO NOT ATTEMPT TO INSTALL OR OPERATE

INSTALLATION AND OPERATING INSTRUCTION



This intermittent pilot ignition (IPI) gas valve (Safety Pilot) kit is set up for Natural gas only and designed to be used with 18 to 30-inch gas log sets. Optional LP conversions kits LPK-18 or LPK-24 are available.

DUE TO HIGH TEMPERATURES THESE MODELS ARE NOT RECOMMENDED FOR INSTALLATION IN SEE THROUGH FIREPLACES

Warning: Improper installation, adjustment, alteration, service or maintenance can cause injury or property damage. Refer to this manual for assistance or for additional information consult a qualified installer, service agency or gas supplier.

Important: Read these instructions carefully before starting installation of your log set.

FOR YOUR SAFETY

WHAT TO DO IF YOU SMELL GAS

- Do not try to light the appliance.
- Do not touch any electrical switch.
- Do not use any phone in your building.
- Immediately call you gas supplier from a neighbor's phone. Follow the gas suppliers instructions.
- If you cannot reach your gas supplier call the fire department.

FOR YOUR SAFETY

Do not store or use gasoline or other flammable vapors and liquids in the vicinity of this or any other appliance.

Young children should be carefully supervised when they are in same room as the appliance.

CALIFORNIA PROPOSITION 65



This product is designed to operate with one of the following fuel sources: Liquid Propane or Natural Gas. The fuel used to operate this product, and the products of combustion of such fuel, can expose you to chemicals including Benzene which is known to the State of California to cause cancer, birth defects and other reproductive harm and Carbon Monoxide which is known to the State of California to cause birth defects or other reproductive harm.

(For more information go to: www.p65Warnings.ca.gov.)

Be sure Flue Damper and Glass Doors are fully open when operating any vented gas log set.

Notice: Please leave these instructions for the consumer. Retain for future reference

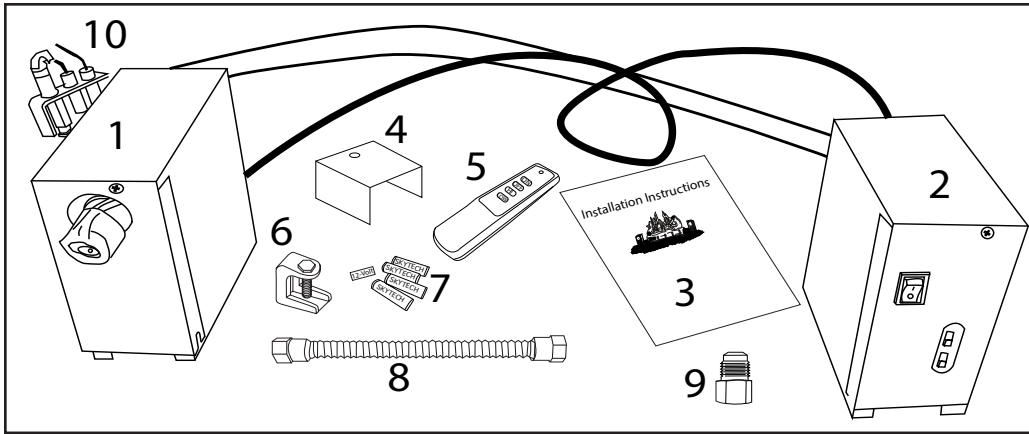

Fig. 1 Contents of Valve Kit

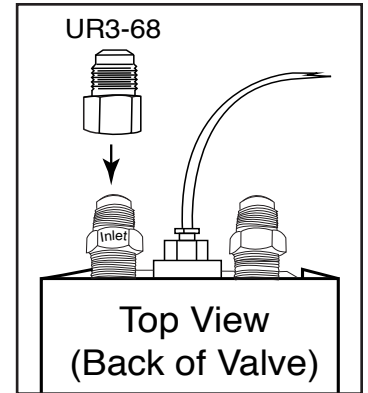

Fig. 2 Installing UR3-68 to the inlet or outlet side of gas valve

CONTENTS: 1- Valve Box, 2- Switch Box (includes battery pack, module and switch - not shown) 3- Installation Instructions, 4- RS-1A Heat Shield, 5- Transmitter, 6- Damper Clamp, 7- (4) AA Batteries, (1) 12-Volt Battery, 8- Flex Connector. 9- Adapter fitting, 10- Pilot assembly

This valve kit is supplied with a (UR3-68) adapter that provides an option to convert the inlet or outlet gas connection from 3/8" flare fitting to a 1/2" flared fitting. Simply thread the UR3-68 on to the inlet/outlet gas flared fitting as shown in Fig. 2.

Note: No pipe joint compound or thread tape is necessary. Ensure fittings are tight and test for gas leaks.

DESCRIPTION: This gas log safety pilot is divided into two sections, the gas Valve Box and the Switch Box. Both boxes are pre-assembled and ready to install. With each box on separate sides of the gas log burner pan it enables the log set to be centered inside fireplace. The Valve Box contains gas valve and pilot assembly and the Switch Box contains electronic module and battery pack. Both boxes are joined together with a high-temperature wiring harness (See Fig. 3).

INSTALLATION PRECAUTIONS

These instructions must be used as a supplement to the instructions supplied with the gas log set. Follow the gas log instructions supplied by the manufacturer on the placement of the burner pan, log basket grate, burner media (sand or vermiculite), ember material and the log placement. Please follow these instructions on the connection of the inlet line to the gas valve and to the burner pan assembly. If this fireplace installation has glass doors, only operate the fireplace with glass doors in the fully open position.

This electronic safety pilot system contains a valve, pilot assembly, module and connector that are certified by CSA under file report number 224930.

NOTE: VALVE BOXES MUST BE LOCATED A MINIMUM OF 2-INCHES FROM SIDES OF BASKET GRATE AND NEVER PLACED DIRECTLY IN FRONT OR BEHIND THE BASKET GRATE. IN ADDITION THE HI-TEMP WIRE HARNESS MUST NEVER BE PLACED UNDER OR IN FRONT THE BURNER PAN.

INSTALLATION INSTRUCTIONS

INSTALLATION: VALVE KIT WITH PRE-INSTALLED LOG SET

1. Make sure gas is completely turned **OFF** to the gas log set. Make sure you have a certified and approved shut-off within 6-feet of the fireplace, or per the local code requirements.
2. Remove all existing logs and basket grate. Set them aside.
3. Disconnect the existing manual valve from the inlet gas supply.
4. Remove existing pilot assembly (if applicable), manual valve and fittings from the burner pan.
5. Locate a position on the back of the burner pan about 4-inches from the right or left side of the burner pan to mount the pilot assembly (See Fig. 4).
6. Mount pilot assembly to burner pan as shown in Fig. 4. **NOTE:** This pilot bracket clips on the burner pan and holds the pilot at a 45° position onto the pan, an attachment screw is recommended. Bend pilot tubing from pilot assembly until the bottom of the pilot bracket is resting against the pan. This will hold the pilot at the 45° position. (Use caution when bending pilot tubing not to kink the tubing and when locating the igniter and flame sensor wires not to locate the wires and the tubing in or over the burner pan.)
7. Locate the Valve Box on the left front corner and the Switch Box in the right front corner of the firebox as far forward as possible (See Fig. 5).

CAUTION: When installing logs on basket grate ensure no logs lay across and touch the valve or switch boxes. Some logs, depending on material, can transfer heat through the metal boxes and cause damage to internal components.

8. Connect inlet supply line to the 3/8" flare fitting on the gas valve. (If using aluminum tubing use caution not to kink the aluminum tube when bending to attach to the valve). **Note:** Use the UR3-68 adapter (if needed) for inlet or outlet gas supply as shown in Fig. 2.
9. Bend 12" stainless flex line (supplied with new kit) and connect to valve outlet. Next connect other end to 3/8" flare fitting on burner pan,
CAUTION: Do not let inlet gas line to the valve kit or gas outlet line from the valve kit be placed inside or overtop of the burner pan. ENSURE HI-TEMP WIRING HARNESS, PILOT ASSEMBLY IGNITION WIRES AND PILOT TUBING ARE LOCATED BEHIND THE BURNER PAN; NOT BURIED UNDER THE SAND AND NOT IN THE PATH OF THE FLAME.
10. Turn gas supply **ON** and check all connections for leaks using soapy water solution before lighting the log set.
11. Follow valve lighting instructions. After the pilot is operating, check **ALL** fittings for leaks.
12. Reinstall basket grate and logs.
13. Install Damper Clamp (supplied with valve kit) which allows damper to remain slightly open to allow the pilot gases to vent).

NOTE: For any PROPANE installations see conversion kit instructions.

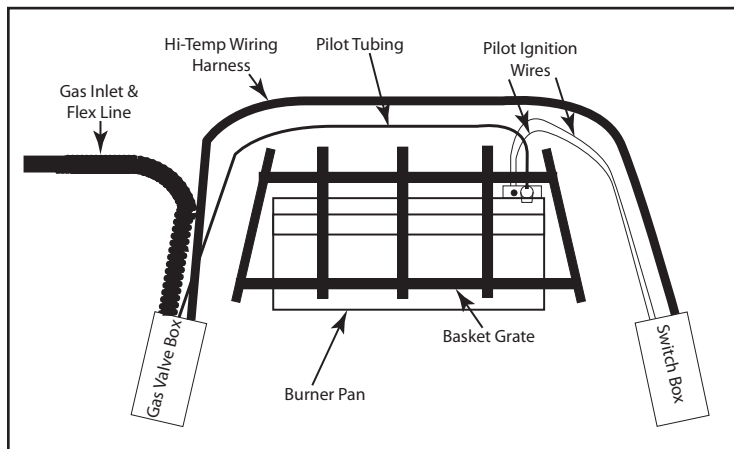

Fig. 3 Basic installation layout centering the grate and components inside the firebox. **NOTE:** This diagram is strictly showing general layout and not to be used for clearance purposes.

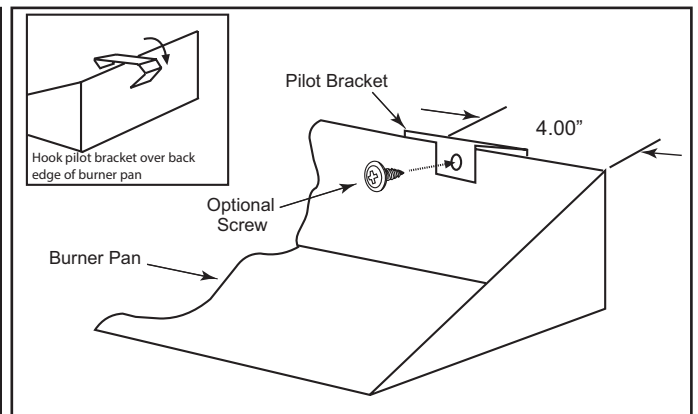

Fig. 4 Pilot Bracket Installation

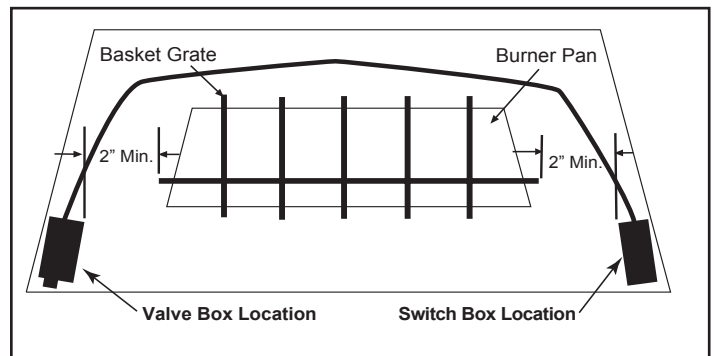

Fig. 5 Minimum Clearances From Basket Grate

INSTALLATION: VALVE KIT WITH A NEW LOG SET

1. Make sure primary gas is turned **OFF** to the log set. Make sure you have a certified and approved shut-off within 6-feet of the fireplace, or per the local code requirements.
2. Follow the instructions supplied with the log set to locate the burner pan. Using the fittings, orifice and gas supply line that came with the log set. Connect the line to the inlet gas supply.
3. Locate a position on the back of the burner pan about 4" from the right or left side of the burner pan (See Figs. 4 & 5).
4. Mount pilot assembly to burner pan as shown in (Fig. 4). **NOTE:** This pilot bracket clips on the burner pan and holds the pilot at a 45° position onto the pan, an attachment screw is recommended. Bend pilot tubing from pilot assembly until the bottom of the pilot bracket is resting against the pan. This will hold the pilot at the 45° position. (Use caution when bending pilot tubing not to kink the tubing and when locating the igniter and flame sensor wires not to locate the wires and the tubing in or over the burner pan.) Locate the Valve Box on the left front corner and the Switch Box in the right front corner of the firebox as far forward as possible (See Fig. 5).

5. Bend inlet gas supply line and connect the 3/8" flare fitting to 3/8" inlet connector on the valve kit (Use caution not to kink the aluminum inlet line when bending to fit to the valve). **Note:** Use the UR3-68 adapter (if needed) for inlet or outlet gas supply as shown in Fig. 2.
6. Bend 12" stainless flex line and connect to valve outlet. Connect other end to 3/8" flare fitting on burner pan. **CAUTION: Do not let inlet gas line to the valve kit or gas outlet line from the valve kit be placed inside or overtop of the burner pan. ENSURE HI-TEMP WIRING HARNESS, PILOT ASSEMBLY IGNITION WIRES AND PILOT TUBING IS LOCATED BEHIND THE BURNER PAN; NOT BURIED UNDER THE SAND AND NOT IN THE PATH OF THE FLAME.**
7. Turn **ON** gas supply and check all connections for leaks using soapy water solution before lighting the log set.
8. Follow valve lighting instructions. After pilot is operating check pilot fittings for leaks.
9. Follow the instructions supplied with the log set to install ember material, basket grate and logs.
10. Install Damper Clamp (supplied with valve kit) which allows damper to remain slightly open to allow the pilot gases to vent).
CAUTION: When installing logs on basket grate ensure no logs lay across and touch the valve or switch boxes. Some logs, depending on material, can transfer heat through the metal boxes and cause damage to internal components.

NOTE: For any PROPANE installations see conversion kit instructions.

IMPORTANT

The new Valve Box **must be placed** a minimum of 2-inches from the basket grate legs and mounted on the left side of the log set. In addition the Switch Box **must be placed** a minimum of 2-inches from the basket grate legs and mounted on the right side of the log set (See Fig. 5). **NOTE:** If a minimum 4-inch clearance can be maintained from the basket grate legs then Valve Box or Switch Box can be placed on either side of the log set. **ALL WIRES MUST BE A MINIMUM OF 2-INCHES AWAY FROM BURNER PAN AT ALL TIMES.**

THIS SECTION IS FOR REFERENCE ONLY

The pilot tubing connection and pilot wiring come pre-assembled to the Valve Box. The electronic module and battery pack come pre-assembled inside the Switch Box.

WIRING FROM THE PILOT ASSEMBLY

1. The "S" (Sensor) and "I" (Ignitor) wires from the pilot assembly are connected at the factory to the "S" & "I" terminals on the electronic module. **NOTE:** The terminal locations in Fig. 7.
2. Route the "S" & "I" wires from the pilot assembly to an area that will be away from the pilot or main burner flame and at least 2-inches from the burner pan.

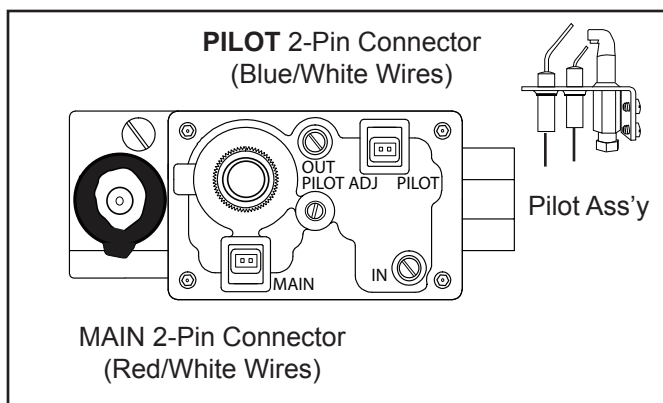

Fig. 6 Gas Valve Identification

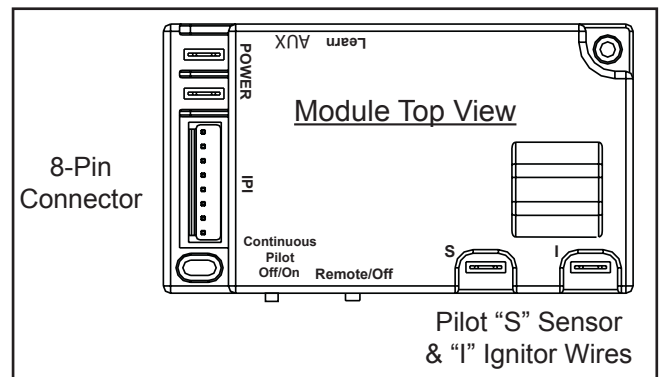

Fig. 7 Module Identification

BATTERY PACK LOCATION

The battery pack is located in the back of the Switch Box inside the black metal case secured with Velcro (See Figs. 8-12). The Switch Box battery pack has a 4-pin connector, 6-inch long wire harness connecting the battery pack to the electronic module. The red and black wires from the battery pack are connected to the coordinating colored wires of the motor drive or solenoid (if applicable to your model). See Figs. 10 & 12. Remove the battery pack during installation. **NOTE:** All Valve Kits are battery powered systems and will not operate without the battery pack. An optional AF-4000ADP24 (120VAC to 7.5VDC adapter) may be used.

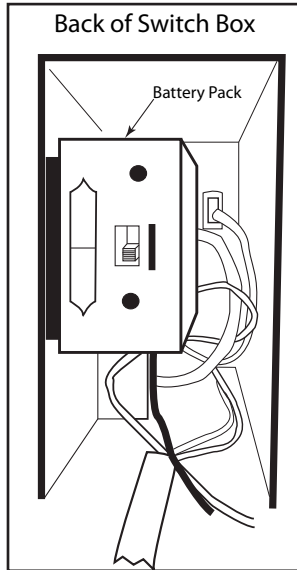

Fig. 8 Battery Pack Location

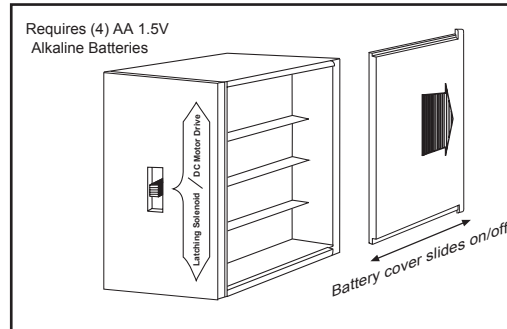

Fig. 9 Installing Batteries

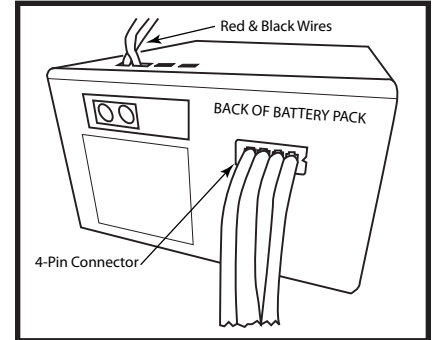

Fig. 10 Battery Pack Wires

INSTALLING BATTERIES INTO THE BATTERY PACK

1. Install (4) AA alkaline batteries (Included) in the battery pack as shown in Fig. 9.
2. The 6-inch 4-pin male connector on the battery pack comes pre-installed to the 4-pin female connector located on the battery pack and module (See Fig. 10).
3. The AFVK-SP-H/L & AFVK-SP-MH/L has (2) 8-inch wires (Red & Black) already connected to the Hi/ Lo solenoid (See Fig.12).
4. After the valve kit installation process is completed reinstall the battery pack back into the back area of the Switch Box as shown in figure 10 install the RS-1A heat shield OVERTOP of battery pack to protect from heat.
5. Ensure any excess wire from the 4-pin wire harness and Hi/Lo wire harness are tucked in the metal box to protect them from heat.

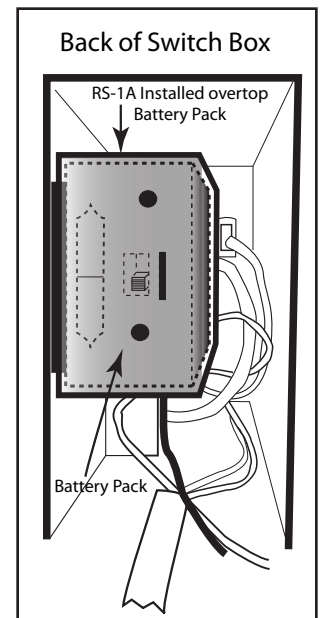

Fig. 11 RS-1A Heat Shield

AFVK-SP-H/L-SPLIT the battery pack switch must be set to *LATCHING SOLENOID* position to operate the HI/LO solenoid. This switch is located on the face of the battery pack (See Fig. 12).

AFVK-SP-MH/L-SPLIT the battery pack switch must be set to *DC MOTOR DRIVE* position to operate the HI/LO feature of the DC Motor Drive. This switch is located on the face of the battery pack (See Fig. 12).

AFVK-SP-SPLIT the battery pack switch can be placed in either position because the red and black wires are removed and not required for this system. Because this kit has a manual flame height control knob the position on the battery pack switch does not matter.

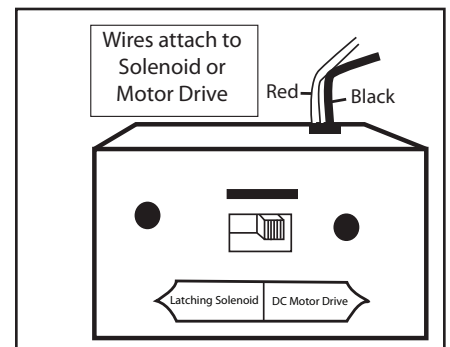

Fig. 12 Battery Pack Switch

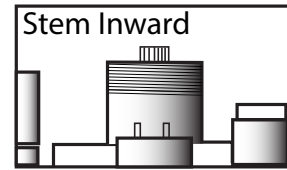
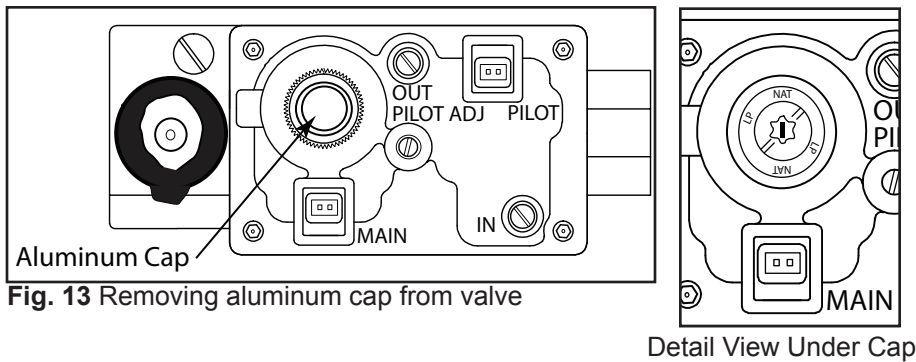

Fig. 14 Gas Valve LP View

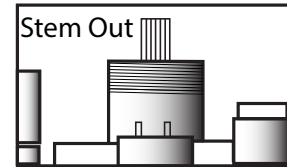

Fig. 15 Gas Valve NAT View

CONVERTING VALVE KITS FROM NATURAL TO LP (PROPANE) GAS

NOTE: When converting a vented log set from NATURAL to LP (PROPANE) it will be necessary to use the LPK-18 or LPK-24. The LPK-18 is used for 18-inch or smaller log sets and the LPK-24 is used for 24 to 30-inch log sets.

The **AFVK-SPLIT VALVE SYSTEMS** use electronic control valves that are convertible from Natural to LP gas by a *Simple Rotary Knob* located on the front “face” of the gas valve (See Fig. 14).

1. Remove the black metal cover from the front of the Valve Box to access the “face” of the control valve.
2. Unscrew the aluminum cap on the front of the gas valve (See Fig. 13). Note the position of the marker on top of the rotary knob shaft. This mark will point to NAT or LP indicating the type of gas the valve is currently set.
3. To convert the valve from the factory setting (NAT) gently push the rotary knob inward with two fingers and rotate left or right to the LP position (See Fig.14). **NOTE:** The marker will now point to LP and the shaft will stay recessed inward.
4. To convert the valve back to the factory setting (NAT) push in the rotary knob and rotate back to NAT. **NOTE:** the marker will now point to NAT and the shaft will remain in the outward position.
5. After the conversion has been made check the outlet pressure with a manometer (main burner must be ON). The factory setting on the internal regulator is 3.5”WC Natural and 10.5”WC LP.
6. Replace the aluminum cap.

NOTE: See the LPK-18 or LPK-24 instructions to convert the burner pan to LP gas this involves installing an orifice air shutter, pilot orifice and media (removing sand and using vermiculite for LP gas).

SPECIAL FEATURES OF THE VALVE KIT ELECTRONIC MODULE

All valve kits modules have (2) special features built into the system as follows:

1. CONTINUOUS PILOT FEATURE:

The AFVK-SPLIT valve kits have a Continuous Pilot feature that may be activated in cold climate conditions or to maintain a draft in the chimney. The continuous pilot can be activated by the following two methods.

Switch on the Front Valve Kit

The Continuous Pilot feature may be activated by placing the “Off/Continuous Pilot” switch located on the front of the valve kit in the “Continuous Pilot” position. See Fig. 16. When this switch is turned to the Continuous pilot position the pilot will immediately begin sparking to light the pilot and the pilot will remain ON.

Button on the Hand Held Remote

To use the continuous pilot feature from the hand held remote control ensure the “Off/Remote” switch on the front of the valve kit is in the “remote” position. See Fig. 16. Simply press the button on the hand held remote marked “Continuous Pilot” (See Fig. 17). The pilot will immediately begin sparking to light the pilot and the pilot will remain ON.

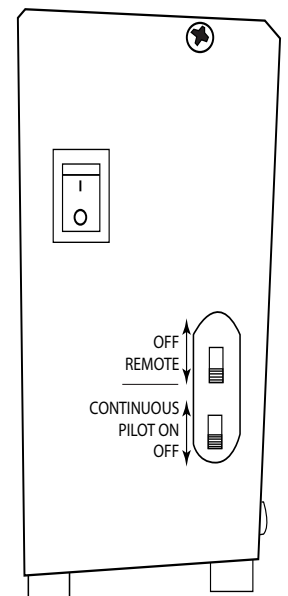

Fig. 16 Module Switches

Note: 7-Day On-Demand Pilot

When the control module is set in the Continuous Pilot mode (either manually or by remote control), a 7-day countdown timer will be started. After 7-days if the main flame has not been turned ON, the control module will turn the pilot OFF. If the main flame is turned ON during the 7-day countdown, the timer is reset and the cycle restarted again.

2. REMOTE CONTROL FEATURE:

NOTE: All Valve Kits come with a remote control transmitter.

The Switch Box electronic module has a built in remote control receiver that allows the user to program a hand held remote transmitter to the appliance at any time during or after installation of the appliance.

1. There is a rocker switch located on the front of the Switch Box (See Fig. 16).
2. When the Remote/Off switch is in the OFF position the Switch Box will operate from the front mounted rocker switch (See Fig. 16). **NOTE:** "O" is Off and "I" is for Ignite.
3. When the Remote/Off switch is in the REMOTE position the appliance will operate from the Remote Control transmitter. **NOTE:** The Switch Box module must be programmed to the Remote transmitter.
4. To program the module; ensure the batteries have been installed in the battery pack and battery pack is removed from Switch Box. Locate the learn button on the module (See Fig. 18). Press and release the learn button with a pen. There will be a beep sound from the module. Then press any key on the remote transmitter. Once the modules internal receiver accepts the transmitter code, there will be a series of rapid beeps. Then remote system is ready for use.

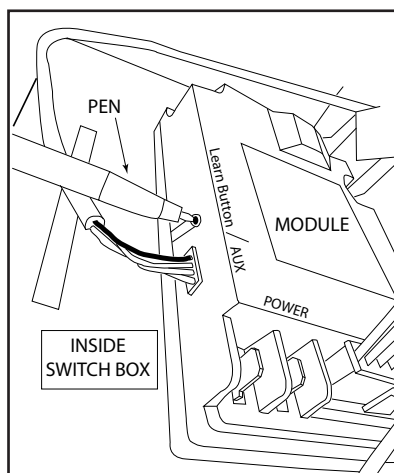

Fig. 18 Learn button on module

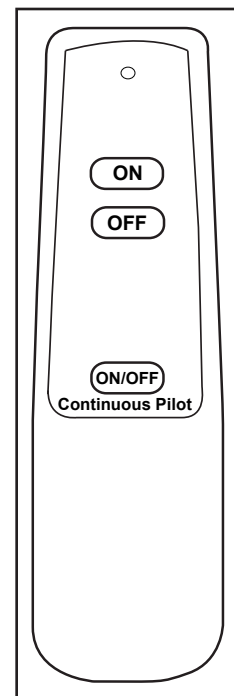

Fig. 17 SP1001 Transmitter

MAINTENANCE OF YOUR AFVK-SP-SPLIT SERIES VALVE KIT SYSTEM

1. Your system should be checked once a year (at the start of the heating season) for proper operation by a qualified service representative.
2. Replace all batteries at the start of the season. Items to check: electronic valve operation, Spark to pilot operation, ON/OFF switch operation, damper operation, visual check of the burner and gas connections for leaks.

FOR YOUR SAFETY READ BEFORE LIGHTING

WARNING: IF YOU DO NOT FOLLOW THESE INSTRUCTIONS EXACTLY, A FIRE OR EXPLOSION MAY RESULT CAUSING PROPERTY DAMAGE, PERSONAL INJURY OR LOSS OF LIFE.

1. This installation should be installed with provisions for combustion and ventilation air, must conform with local codes or in the absence of local codes to the national fuel Gas Code ANSI Z223 latest addition.
2. This product must be on a gas supply line that is less than 1/2 psi. and an individual manual shut-off.
3. Never operate this new system with the glass fireplace enclosures (doors) in the closed position.
4. Connecting 110-volt electrical power to this product directly will cause damage and will void warranty.

OPERATING PROCEDURE

After installation is completed follow these steps to operate the AFVK-SP-SPLIT.

1. Turn **ON** the main gas supply and check all fittings and connections for leaks with soap and water solution.
2. Move the OFF/REMOTE slide switch on the front of Switch Box to the REMOTE position (See Fig. 16).
3. Push the ON button on the remote transmitter this will start the ignition system. The pilot will begin to spark and then light. Once the pilot is lit for 2 seconds the main burner will light.
4. Adjust the main flame from HI to LO with the manual HI/LO knob on front of valve kit.

NOTE: To manually start the valve kit, move the OFF/REMOTE slide switch on the front of the Switch Box to the OFF position then push the rocker switch to the "I" position this will light the main burner. Once the pilot is lit for 2 seconds the main burner will light.

After the installation is complete follow these steps to operate the AFVK-SP-HL-SPLIT or AFVK-SP-MHL-SPLIT

1. Turn **ON** the main gas supply and check all fittings and connections for leaks with soap and water solution.
2. Move the OFF/REMOTE slide switch on the front of Switch Box to the REMOTE position (See Fig. 16).
3. Push the ON button on the remote transmitter position this will start the ignition system. The pilot will begin to spark and then light once the pilot is lit 2 for seconds later the main burner will light.
4. Adjust the main flame from HI to LO with the HI/LO buttons on the remote transmitter.

NOTE: To manually start the valve kit, move the OFF/REMOTE slide switch on the front of the Switch Box to the OFF position then push the rocker switch to the "I" position this will light the main burner. Once the pilot is lit 2 seconds the main burner will light.

AFVK-SP-H/L press and release the LO button and the flame will switch to LO. Press and release the HI button and the flame will switch to HI.

AFVK-SP-MH/L press and hold the LO button and the flame will modulate to LO. Press and hold the HI button and the flame will modulate to HI.

IMPORTANT NOTE: On initial start up: due to air in the gas supply line it may take an extended amount of time for the pilot to light. There is a 60 second lockout built into the module. To reset, turn the rocker switch OFF, then ON, or push the OFF button on the remote transmitter, then push the ON button.

TROUBLESHOOTING

CAUTION: An experienced qualified service technician should only perform troubleshooting procedures.

PILOT WILL NOT STAY LIT:

1. Confirm that the "S" sensor wire and the "I" igniter wires are properly connected to the module "S" and "I" terminals on the module (See figure 6 for terminal locations).
2. Confirm that the Spark to Pilot burner is properly grounded to the gas control valve (Ground is provided through the pilot tubing).
3. Check the ground wire from the module to the gas control valve (Black ground wire on the 8 pin connector)
4. Check the power source battery pack connections and voltage of batteries.
5. Optional check the position of the CONTINUOUS PILOT switch on the Switch Box (See Fig. 17).

MAIN BURNER DOES NOT COME ON WHEN THE MANUAL ROCKER SWITCH OR REMOTE CONTROL IS ON:

1. Confirm that the pilot sparks and lights.
2. Check the (2) pin plastic connectors that plug in the face of the gas control valve (See Fig. 6).
3. Confirm that the gas control valve is properly grounded to the valve kit module.

CONTINUOUS PILOT SHUT OFF AFTER A PERIOD OF TIME

1. If the control module is set in the Continuous Pilot mode (either manually or by remote control), a 7-day countdown timer will be started. After 7-days if the main flame has not been turned ON, the control module will turn the pilot OFF. If the main flame is turned ON during the 7-day countdown, the timer is reset and the cycle restarted again.
2. When continuous pilot is turned OFF, simply press the ON button on the remote control or press the rocker switch to ON to light the system in a normal fashion. The 7-day timer will reset unless you turn the continuous pilot switch to the OFF position.

REMOTE WON'T OPERATE VALVE

1. Ensure the module switch is in Remote position and check batteries in the remote and the battery pack.
2. Clear Codes: Memory in the module might be full if the learn button is pressed too many times. If this happens no audible beep will be heard. To clear memory, place the module slide switch into the REMOTE position. Press the learn button and release after 10 seconds. You should hear three (3) long audible beeps indicating all codes have cleared. You can now "relearn" the transmitter to the module as described below.
3. Press the LEARN button on the module to accept the transmitter security code. Ensure the slide button on the module is in the REMOTE position; the module will not LEARN if the slide switch is in the OFF position. The LEARN button is located on the side of the module (See Fig. 18). Using the pen or toothpick gently press and release the black LEARN button inside the hole. When you release the LEARN button the module will emit an audible "beep". After the module emits a beep press the transmitter ON button and release. The module will emit several beeps indicating that the transmitter's code has been accepted into the module then you can presume normal operation.

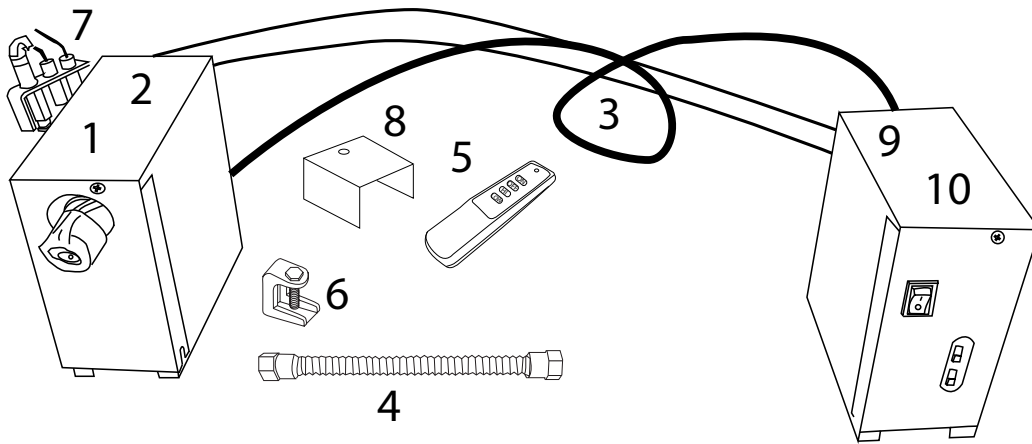

AFVK-SP-SPLIT SERIES VALVE KIT PARTS LIST

Item	Description	Part Number
1	AFVK-SP-SPLIT Gas Valve with Manual Hi/Lo Control	AF-4014
1	AFVK-SP-HL-SPLIT Gas Valve with Solenoid	AF-4024
1	AFVK-SP-MHL-SPLIT Gas Valve with DC Motor Drive	AF-4034
2	3/8" Flare x 3/8" NPT Fitting (not shown)	685-22
3	Wire Harness (392°F High Temperature Wire) with Black Silicon Sleeve	AF-40008PINSKIT42
4	10" Stainless Steel Flex Connector	T102-9898-10
5	Transmitter for AFVK-SP Models	SP1001
5	Transmitter For AFVK-SP-H/L & MH/L Models	SP1001H/L
6	Damper Clamp	685-14
7	Complete Pilot Assembly (Spark to Pilot with 60-inch leads)	AFVK-SP-PILOT60
8	Heat Shield (Protects battery pack)	RS-1A
9	Battery Pack (not shown)	AF-4000BP
10	Control Module (not shown)	AF-4000MOD-1
11	3/8" to 1/2" adapter (increases 3/8" flare to 1/2" flared; not shown)	UR3-68

OPTIONAL ACCESSORIES

TMR-AF1-TX	Wireless Wall Mounted Timer (30-60-120 Minute Time Options)
1001D-AF1-TX	Wireless ON/OFF Wall Switch
AF-4000ADP24	120VAC to 6-volt Adapter (Allows system to operate without batteries)

Limited Warranty

American Flame warrants the AFVK-SP-SPLIT VALVE KIT SYSTEMS for 12 months from the date of purchase or installation to the original purchaser to be free from defects in materials and workmanship. Damage to the AFVK-SP-SPLIT VALVE KIT SYSTEMS caused by accident, misuse, abuse, or installation error, whether performed by a contractor, Service Company, or owner, is not covered by this warranty. American Flame will not be responsible for labor charges and/or damage incurred in installation, repair, replacement, or for incidental or consequential damage. Some states, provinces, and nations do not allow exclusion or limitations of incidental or consequential damages, so the above limitations or exclusions may not apply.

This warranty gives you specific legal rights. You may also have other rights that vary by state, province, or nation.

FOR TECHNICAL QUESTIONS, CALL: (855) 498-8324

Sales Support: (888) 699-6167

www.skytechpg.com

Skytech Products Group, 9230 Conservation Way, Fort Wayne, IN 46809

