



Portable Air Conditioner

Instruction Manual



WA-P903E: 14,000BTU (cooling only)

Thank you for purchasing our Portable Air Conditioner.
Before using your air conditioner, please read this instruction manual carefully and keep it for future reference.
READ AND SAVE THESE INSTRUCTIONS!

| Contents

Preparation	2
Safety Precautions	3
Cautions	4
Design and Compliance Notes	4
Installation	5
Operation	9
Maintenance	13
Trouble Shooting	14
Sociable Remark	14
Using the Remote Controller	15
Warranty Info	25

Preparation

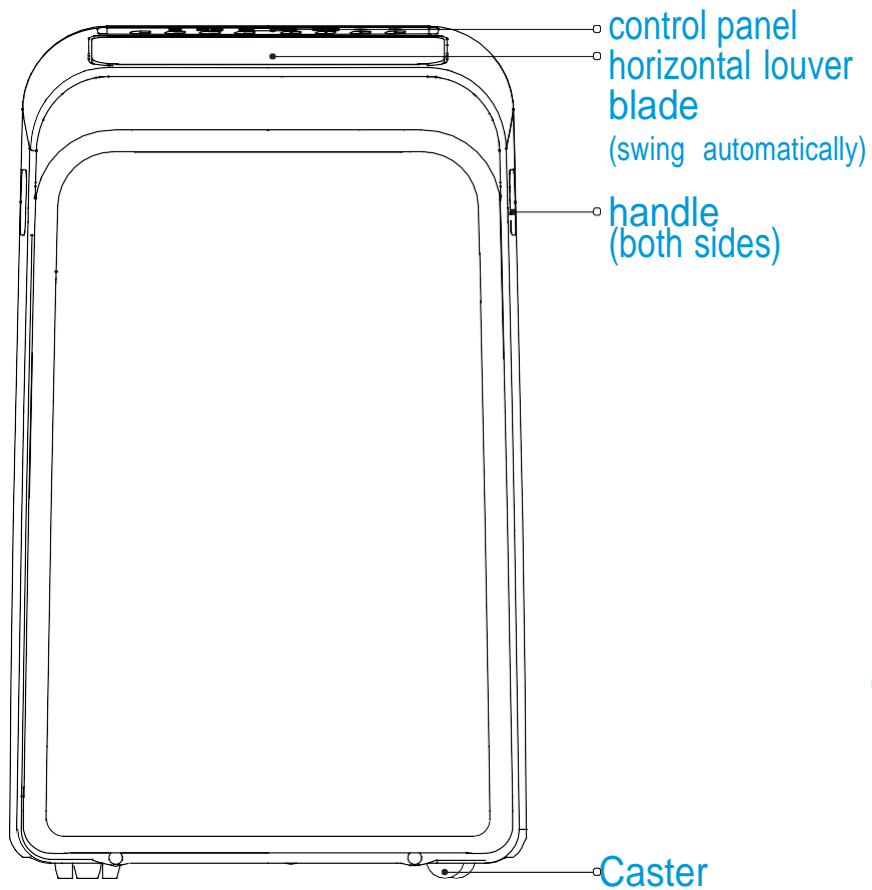

front

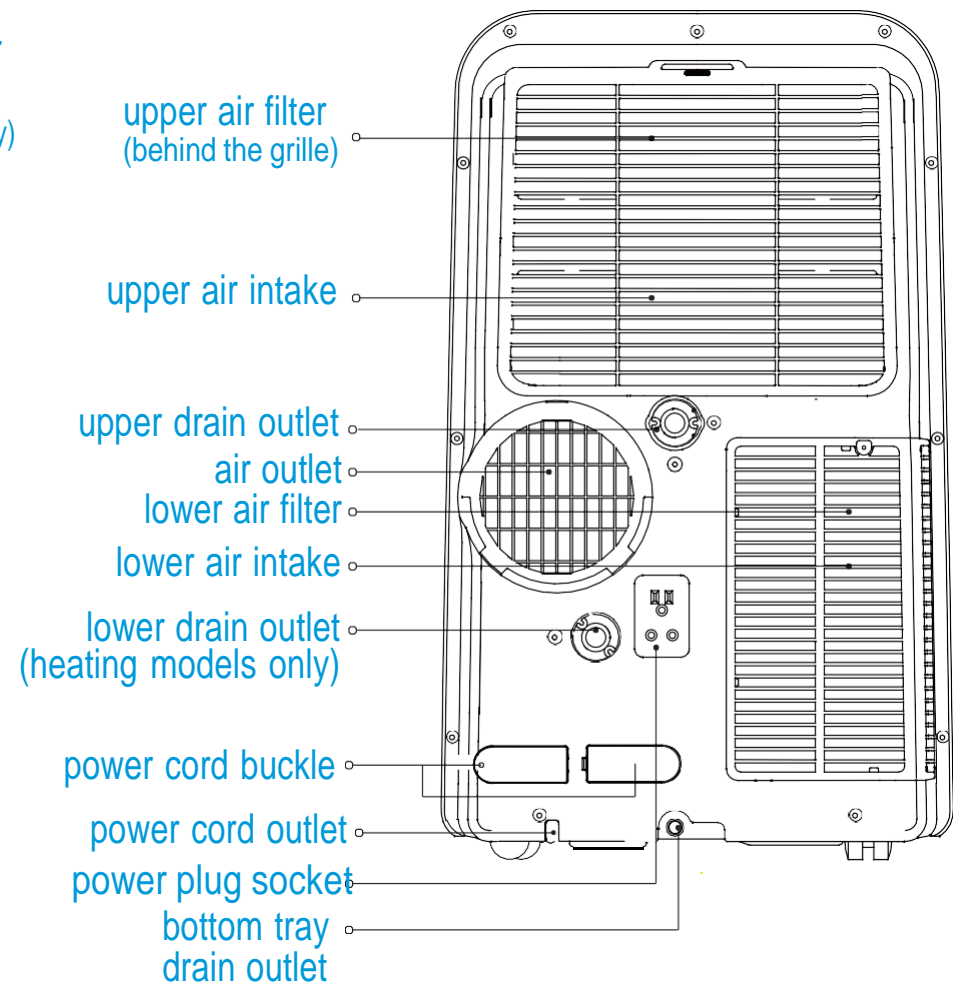

rear

| Safety Precautions

Please read through these instructions before you start the installation process. Improper installation can cause damage to the unit, your personal property, and also poses a personal safety hazard.

- Installation must be performed in accordance to the installation instructions. Improper installation can cause water leakage, electrical shock or fire.
- Use only the included accessories, parts and specified tools for installation. Using non-standard parts can cause water leakage, electrical shock, fire, injury or property damage.
- Make sure the outlet to be used is grounded and has the appropriate voltage. The power cord is equipped with a three-prong grounding plug to protect against shock. Voltage information can be found on the side of the unit, behind the grille.
- Install the unit on a flat and sturdy surface. Failure to do so could result in damage or excessive noise and vibration.
- The unit must be kept free from obstruction to ensure proper function and to mitigate safety hazards.
- DO NOT modify the length of the power cord or use an extension cord. DO NOT share a single outlet with other electrical appliances. Improper power supply can cause fire or electrical shock.
- DO NOT install the air conditioner in a wet room such as a bathroom or laundry room. Too much exposure to water can cause electrical components to short circuit.
- DO NOT install the unit in a location that may be exposed to combustible gas, as this could cause fire.
- The unit has wheels to facilitate moving. Be cautious when using on thick carpets. Do not roll over objects to avoid tipping.
- DO NOT operate an unit that has been dropped or damaged.
- Only use the included accessories and specified parts for installation. Using nonstandard parts can cause water leakage, electrical shock, fire, injury or property damage.
- The unit must be kept free from obstruction to ensure proper function.
- DO NOT allow children to play with the air conditioner.
- Children must be supervised around the unit at all times.
- If the air conditioner is knocked over during use, turn off the unit and unplug from power supply immediately. Visually inspect the unit to ensure there is no damage. If you suspect the unit has been damaged, contact Sunpentown.
- In a thunderstorm, the power must be cut off to avoid damage due to lightning.
- The air conditioner is to be used in such a way that is protected from moisture (condensation, splashed water, etc). Do not place or store the unit where it can fall or be pulled into water or any other liquid. Unplug immediately if this occurs.
- Always transport the unit in a vertical position.
- Keep a minimum clearance of 12 inches around the unit for proper airflow (from walls, furniture and curtains).
- When the unit is not in good order, please use common sense to prevent further damage to surroundings.
- Do not remove any fixed covers.
- Never use the plug to start or stop the unit.
- Do not cover or obstruct the inlet or outlet grilles.
- Do not use hazardous chemicals to clean or allow to come in contact with the unit.
- Do not use the unit in the presence of inflammable substances or vapors such as alcohol, insecticides, petrol, inc.

Cautions

- This appliance can be used by children aged from 8 years and above and persons with reduced physical, sensory or mental capabilities or lack of experience and knowledge if they have been given supervision or instruction concerning use of the appliance in a safe way and understand the hazards involved. Children shall not play the appliance. Cleaning and user maintenance shall not be made by children without supervision.
- This appliance is not intended for use by persons (including children) with reduced physical, sensory or mental capabilities or lack of experience and knowledge, unless they have been given supervision or instruction concerning use of the appliance by a person responsible for their safety.
- Children should be supervised to ensure that they do not play with the appliance.
- Do not operate unit with a damaged cord or plug. If the supply cord is damaged, it must be replaced by the manufacturer, its service agent or similarly qualified persons in order to avoid a hazard.
- The appliance shall be installed in accordance with national wiring regulations.
- Do not operate your air conditioner in a wet room such as a bathroom or laundry room.
- Contact Sunpentown regarding issues on repair or maintenance of this unit.
- Contact Sunpentown with questions regarding installation of this unit.
- When there are differences between USERS MANUAL and Remote controller illustration on function description, the description on USERS MANUAL shall prevail.
- If the air conditioner is knocked over during use, turn off the unit and unplug from the main power supply immediately. Visually inspect the unit to ensure there is no damage.
- If you suspect the unit has been damaged, contact Sunpentown for assistance.
- Prior to cleaning or other maintenance, please disconnect from power.
- To reduce the risk of fire or electric shock, do not use this fan with any solid-state speed control device.
- Do not install the appliance in a location that may be exposed to combustible gas.
- Do not run cord under carpeting. Do not cover cord with throw rugs, runners, or similar coverings. Do not route cord under furniture or appliances. Arrange cord away from traffic area and where it will not be tripped over.

Design and Compliance Notes

Design Notice

In order to ensure the optimal performance of our products, the design specifications of the unit and remote control are subject to change without prior notice.

Energy Rating Information

The Energy Rating for this unit is based on an installation using an un-extended exhaust duct without adapters A or B (as shown in the Installation section of this manual).

| Installation

Choosing The Right Location

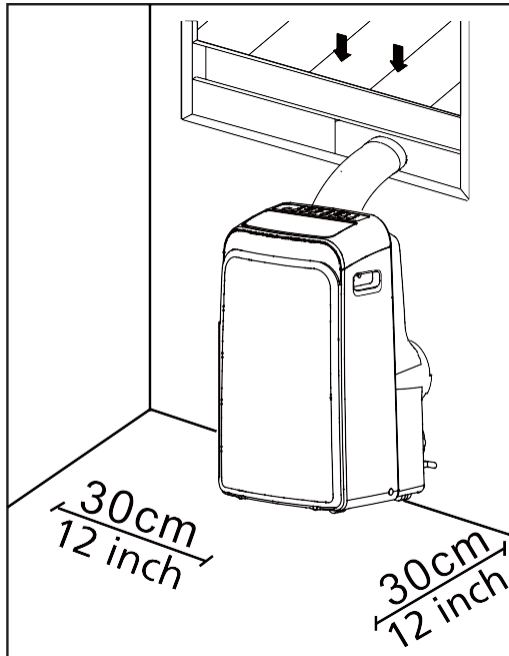

- Your installation location should meet the following requirements:
- Make sure that you install your unit on an even surface to minimize noise and vibration.
 - The unit must be installed near a grounded plug, and the Collection Tray Drain (found on the back of the unit) must be accessible.
 - The unit should be located at least 30cm (12") from the nearest wall to ensure proper air conditioning.
 - DO NOT cover the Intakes, Outlets or Remote Signal Receptor of the unit, as this could cause damage to the unit.

Recommend Installation

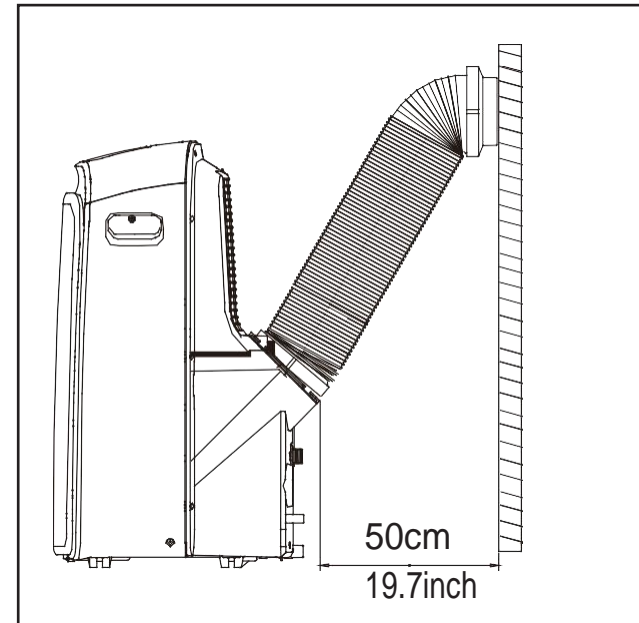

NOTE:

All the illustrations in the manual are for explanation purpose only. Your machine may be slightly different. The actual shape shall prevail.

The unit can be controlled by the unit control panel alone or with the remote controller. This manual does not include Remote Controller Operations, see the <<Remote Controller Instruction>> packed with the unit for details.













Installation

Tools Needed

- Medium Philips screwdriver; -Tape measure or ruler; -Knife or scissors;
- Saw (optional, to shorten window adaptor for narrow windows)

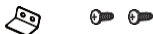
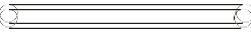
Accessories

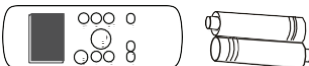
Your Window Installation Kit fits windows 67.5-123cm(26.5-48") and can be shortened for smaller windows.

Part	Description	Quantity
	Unit Adaptor	1 pc
	Exhaust Hose	1 pc
	Window Slider Adaptor	1 pc
	Bolt	1 pc
	Window Slider A	1 pc
	Window Slider B	1 pc
	Foam Seal A (Adhesive)	2 pc
	Foam Seal B (Adhesive)	2 pc
	Foam Seal C (Non-adhesive)	1 pc
	Security Bracket and 2 Screws	1 set
	Drain Hose	1 pc
	Drain Hose Adaptor (for Heating models only)	1 pc
	Remote Controller (2 AAA batteries)	1 pc
	Wall adaptor for through-the-wall installation (Not included, option to purchase) Please refer to page 8 for installation instructions.	

Check all accessories are included in the package and please refer to the installation instructions for their usage. Note: All illustrations in this manual are for explanation purposes only. Your air conditioner may be slightly different, the actual shape shall prevail.

Window Installation Kit

Step One: Preparing the Exhaust Hose assembly

Press window slider adaptor and unit adaptor onto the exhaust hose. Clips on the adaptors will automatically clamp onto the exhaust hose.

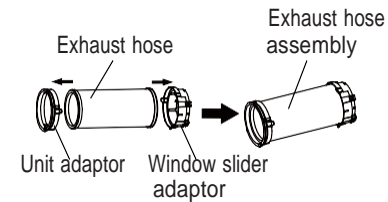

Step Two: Install the Exhaust hose assembly to the Unit

Align the hooks on the unit adaptor to the hole seat of the air outlet (located on the back of the unit). Insert adaptor and slide hose assembly downwards into the groove.

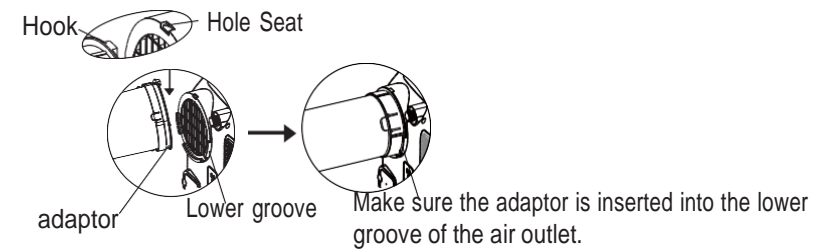

Step Three: Preparing the Adjustable Window Slider

Depending on the size of your window, adjust slider kit accordingly. If the window requires both pieces of the slider kit, adjust to needed length and secure with bolt.

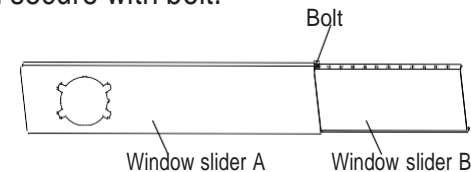

Note: If the window opening is less than the minimum length of the slider kit, cut Slider A. Cut the solid end, DO NOT cut out the openings.

Installation

Note: Once the exhaust hose assembly and adjustable slider kit are prepared, choose from one of the following installation methods.

Type 1: Hung Window Installation

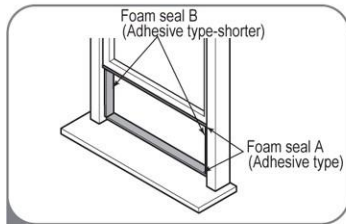

Cut the adhesive foam seal A and B strips to the proper lengths and attach them to the window sash and frame.

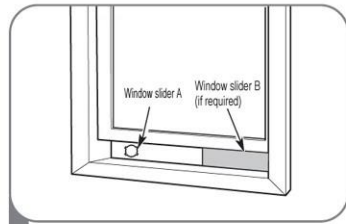

Insert the slider kit assembly into window opening.

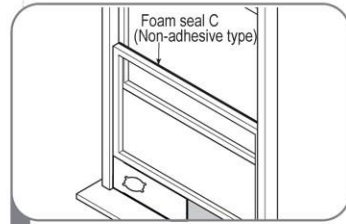

Cut the non-adhesive foam seal C to match the width of the window. Insert the seal between the glass and the window frame to prevent air and insect from getting into the room.

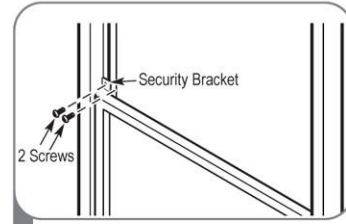

If desired, install the security bracket with 2 screws.

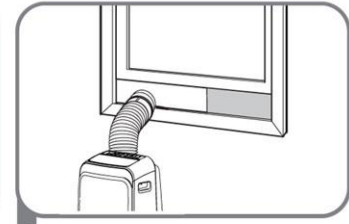

Insert the slider kit adaptors into the holes on the slider kit.

Type 2: Sliding Window Installation

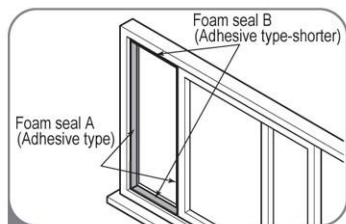

Cut the adhesive foam seal A and B strips to the proper lengths and attach them to the window sash and frame.

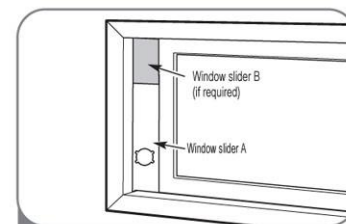

Insert the slider kit assembly into window opening.

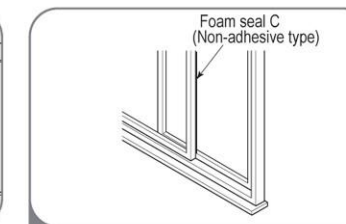

Cut the non-adhesive foam seal C to match the length of the window. Insert the seal between the glass and the window frame to prevent air and insect from getting into the room.

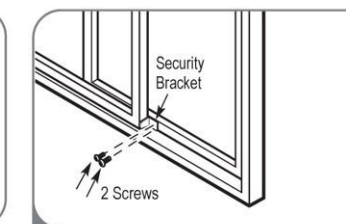

If desired, install the security bracket with 2 screws.

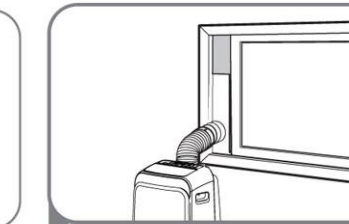



Insert the slider kit adaptors into the holes on the slider kit.

Installation

Through-the wall connection

Note: It is necessary to purchase the following parts for through-the-wall installation:

	Wall Adaptor (sold separately, please contact Sunpentown at 1-800-330-0388 or visit www.sunpentown.com)
	Screws & expansion plugs (can be purchased at any hardware store)

1. Prepare a hole in the wall and install Wall Adaptor to the opening (from outside). Secure with 4 expansion plugs and screws.
2. Attach exhaust hose to the Wall Adaptor.

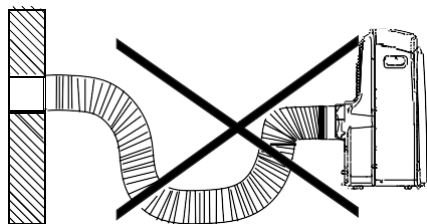
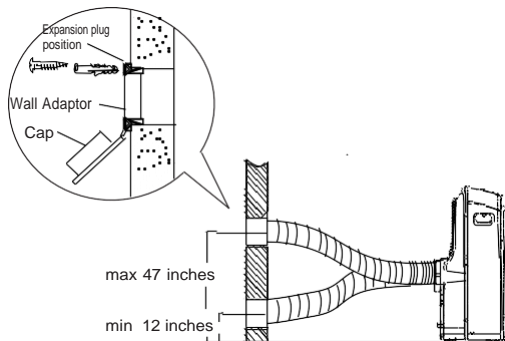

Cover the hole using the adaptor cap when not in use.

IMPORTANT:

DO NOT OVER BEND THE EXHAUST HOSE

The exhaust hose can be compressed or extended moderately according to the installation requirement, but it is desirable to keep the hose length to a minimum.

⚠ CAUTION:

Note: to ensure proper function, DO NOT overextend or bend the hose. Make sure that there is no obstacle around the air outlet of the exhaust hose (in the range of 20 inches) for the exhaust system to work properly. All illustrations in this manual are for explanation purposes only.



Operation

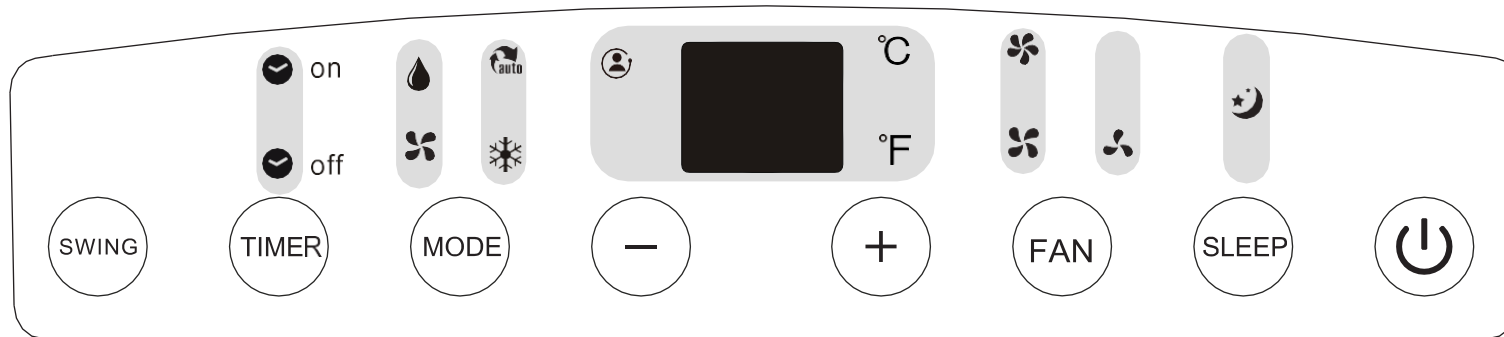

SWING **Swing button**
Used to initiate the Auto swing feature. If auto-swing is in function, press the button again to stop the louver at desired angle.

TIMER **Timer button**
Used to initiate the AUTO ON (start time) and AUTO OFF (stop time) programs. Used in conjunction with the + and - buttons. The corresponding timer indicator light will illuminate.

MODE **Mode button**
Selects the appropriate operating mode. Each press of the button will select mode in the following sequence: AUTO, COOL, DRY, FAN and HEAT (heating models only). The corresponding mode indicator will illuminate.

- **+** **Up (+) and Down (-) buttons**
Used to increase or decrease temperature setting in 1°C/1°F increments.
Adjustable range: 62°F to 86°F (17°C to 35°C)
Also used to set timer between of 0~24hrs.

NOTE: The control is capable of displaying temperature in Fahrenheit or Celsius. To convert from one to the other, press and hold the Up and Down buttons simultaneously for 3 seconds.

FAN **Fan button**
Controls the fan speed. Press to select the fan speed in four steps: LOW, MED, HIGH and AUTO. The corresponding fan speed indicator will illuminate, except for AUTO speed. When AUTO is selected, all fan indicators are dark.

SLEEP **Sleep button**
Used to initiate the SLEEP function.

Power button
Power switch, turns unit on/off.

Operation



LED display

Displays set temperature, in either °C or °F.
 Displays auto-timer settings (if any)
 When unit is in DRY or FAN modes, displays current room temperature.

Displays error codes and protection codes:
 E1: Room temperature sensor error
 E2: Evaporator temperature sensor error
 E3: Condenser temperature sensor error
 E4: Display panel communication error
 P1: Bottom tray is full. Connect the drain hose to drain and empty the bottom tray.

Note: When one of the above malfunction occurs, turn off the unit and check for any obstructions. Restart the unit, if the error persists, turn off unit and unplug power cord. Contact Sunpentown customer service at 800-330-0388.



CAUTION! If unit is stopped or powered off unexpectedly, there will be a 3-minute delay before unit will start up again. This is to protect the compressor. Unit will automatically resume after 3 minutes.

Operating Temperature Range

Mode	Temperature Range
Cool	17-35°C (62-95°F)
Dry	13-35°C (55-95°F)
Heat (heating models only)	5-30°C (41-86°F)

Operation Instructions

COOL operation

- Press the MODE button until COOL indicator lights up.
- Press the + or - button to set desired room temperature. Temperature range is between 62°F~86°F (17°C~30°C).
- Press the FAN button to choose desired fan speed.

HEAT operation ((heating models only)

- Press the MODE button until HEAT indicator lights up.
- Press the + or - button to set desired room temperature. Temperature range is between 62°F~86°F (17°C~30°C).
- Press the FAN button to choose desired fan speed.

FAN operation

- Press the MODE button until FAN indicator illuminates.
- Press the FAN button to select desired fan speed.
- The temperature cannot be adjusted.
- Exhaust hose connection is not needed.

DRY (dehumidify) operation

- Press the MODE button until the DRY indicator light illuminates.
- Under this mode, fan speed cannot be selected and temperature cannot be set. The fan operates at LOW.
- Keep windows and doors closed for the best dehumidifying effect.
- Do not connect exhaust hose fixture to window.

AUTO operation

- When the unit is set in AUTO mode, it will automatically select cooling or fan mode, depending on set temperature and ambient room temperature.
- The air conditioner will operate in the appropriate mode based on the set temperature.
- Under AUTO mode, fan speed cannot be set.

Operation

TIMER function

When the unit is operating:

- Press the TIMER button to program auto-stop, the TIMER OFF indicator will illuminate. Press the + or - buttons to set the time for unit to turn off.
- Press the TIMER button again within 5 seconds will allow you to program auto-start. The TIMER-ON indicator will illuminate. Press the + or - buttons to set the time for unit to turn on.

When the unit is off:

- Press the TIMER button to program auto-start, the TIMER ON indicator will illuminate. Press the + or - buttons to set the time for unit to turn on.
- Press the TIMER button again within 5 seconds will allow you to program auto-stop. The TIMER-OFF indicator will illuminate. Press the + or - buttons to set the time for unit to turn off.
- Press or hold the +/- button to change time in 0.5 hour increments, up to 10 hours; then in 1 hour increments, up to 24 hours. The control panel will count down the remaining time until program begins.
- The display will automatically revert back to displaying the previous temperature setting if there is no activity within a 5 second period.
- After time has been programmed, if unit is manually turned ON or OFF; or if the timer setting is adjusted to 0.0, all timer programs will be cancelled.
- When unit malfunctions and error codes E1, E2, E3 or E4 is displayed, timer programs will also be cancelled.

SLEEP function

- If unit is running in COOL mode when SLEEP function is activated, unit will automatically increase set temperature by 1°C/2°F after 30 minutes. After another 30 minutes, unit will again increase temperature by 1°C/2°F.
- Unit maintains the new temperature for 7 hours, then returns to original set temperature. This ends the Sleep function and unit operates as originally programmed.

NOTE: This feature is unavailable under FAN or DRY mode.

Other features

Auto-Restart

If the unit turns off unexpectedly due to loss of power, it will restart at the previous settings when power resumes.

Air Flow Adjustment (SWING)

- When the unit powers on, the louver opens fully.
- Press the SWING button to initiate the auto-swing. The louver will automatically swing up and down.
- For fixed angle, press SWING button when louver is at desired angle.

NOTE: Please do not adjust the louver manually.

Operation

Water drainage

Continuous Drainage for DRY mode

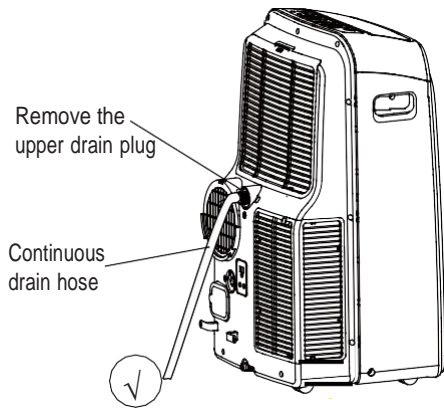

- Remove the upper drain plug from back of unit.
- Attach drain connector (5/8" universal female mender) to a 3/4" hose (not included, purchase locally). Connect to spout. For models without the drain connector, just attach drain hose to spout.
- Position the open end directly over drain area.

Continuous Drainage for HEAT mode (required) (Heating models only)

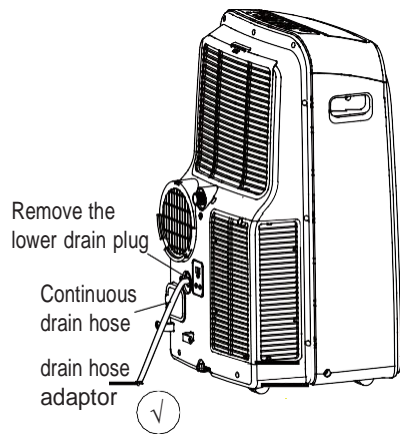

- Remove the lower drain plug from the back of the unit.
- Attach drain connector (5/8" universal female mender) to a 3/4" hose (not included, purchase locally). Connect to spout.
- Position the open end directly over drain area.
- The continuous drain for Heat mode has a built-in pump, maximum height for the drain hose is 5 feet.

NOTE: Make sure connection is secure to prevent leakage. Direct the hose towards the drain, making sure there are no kinks that may stop the water flow. Place the end of the hose into the drain and make sure the end of hose is down to let water flow smoothly.

When continuous drain is not used, be sure the corresponding drain plug and knob are firmly installed in

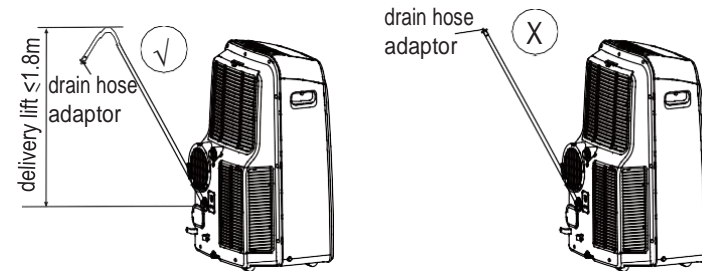

Emptying the Water Tank

When the water in the bottom tray reaches its maximum capacity, the unit will beep 8 times and display will show "P1". At this time, the compressor will immediately stop but fan will continue to operate.

- Place a collection pan underneath the bottom tray drain spout or carefully move the unit to a drain location.
- Remove the bottom drain plug and water will begin to drain out.
- Replace the drain plug and restart unit. P1 indicator should disappear.

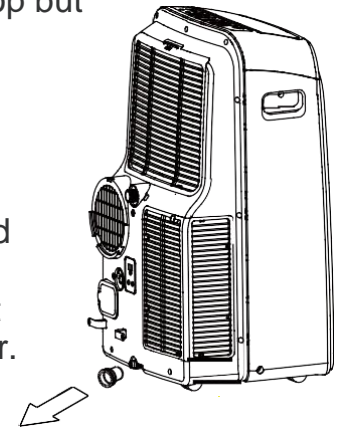

Maintenance

Safety Precautions

- Always unplug the unit before cleaning or servicing.
- DO NOT use flammable liquids or chemicals to clean the unit.
- DO NOT wash the unit under running water. Doing so causes electrical danger.
- DO NOT operate the machine if the power cord is damaged. Contact Sunpentown or a qualified electrician.

Clean the Air Filter

Clean the filters at least once every two weeks to prevent inferior fan operation due to dust accumulation.

- Clean filters by washing in warm water (40°C/104°F) with a neutral detergent.
- Rinse clean and allow to dry in a shady area. Do not place under direct sunlight.

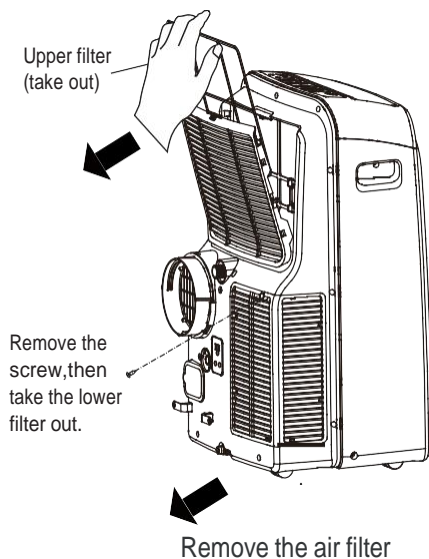

Maintenance Tips

- The water collection tray should be drained immediately after P1 error occurs, and before storage to prevent mold.
- In households with animals, you will have to periodically wipe down the grill to prevent blocked airflow due to animal hair.

Clean the Unit

Use a lint free cloth soaked with neutral detergent to clean the housing. Finished by a dry clean cloth.

Storage

- Drain the unit's water collection tray according to the instructions in the previous section.
- Run the appliance on FAN mode for 12 hours in a warm room to dry the interior and prevent mold.
- Turn off the appliance and unplug power source.
- Clean the air filter according to the instructions in the previous section and reinstall.
- Remove the batteries from the remote control.



Store unit in a cool, dark place. Exposure to direct sunlight or extreme heat can shorten the life span of the unit.

Trouble Shooting

Please check the machine according to the following before asking for maintenance:

Problem	Possible Cause	Troubleshooting
Unit does not turn on when pressing ON/OFF button	P1 Error Code	The Water Collection Tray is full. Turn off the unit, drain the water from the Water Collection Tray and restart the unit.
	In COOL mode: room temperature is lower than the set temperature	Reset the temperature
Unit does not cool well	The air filter is blocked with dust or animal hair	Turn off the unit and clean the filter according to instructions
	Exhaust hose is not connected or is blocked	Turn off the unit, disconnect the hose, check for blockage and reconnect the hose
	The unit is low on refrigerant	Call a service technician to inspect the unit and top off refrigerant
	Temperature setting is too high	Decrease the set temperature
	The windows and doors in the room are open	Make sure all windows and doors are closed
	The room area is too large	Double-check the cooling area
	There are heat sources inside the room	Remove the heat sources if possible
The unit is noisy and vibrates too much	The ground is not level	Place the unit on a flat, level surface
	The air filter is blocked with dust or animal hair	Turn off the unit and clean the filter according to instructions
The unit makes a gurgling sound	This sound is caused by the flow of refrigerant inside the unit	This is normal

Sociable Remark

Do not dispose this product as unsorted municipal waste. Collection of such waste separately for special treatment is necessary.

It is prohibited to dispose this appliance in domestic household waste. When this product reaches the end of its useful life, do not dispose with general household waste. For the correct collection and treatment of this product, take them to the collection point for reuse of electrical and electronic equipment. Contact your local authority for the appropriate collection point in your neighborhood.

dispose packaging materials, such as plastic and carton, in the appropriate waste bins.

Wild disposal of waste in forests and landscapes endangers your health when hazardous substances leak into the groundwater and find their way into the food chain.

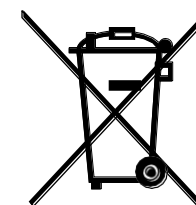

USING THE REMOTE CONTROLLER

Remote Controller Specifications

Battery Required	AAA battery x 2
Signal Receiving Range	8m
Operating temperature	-5°C ~ 60°C (23°F ~140°F)

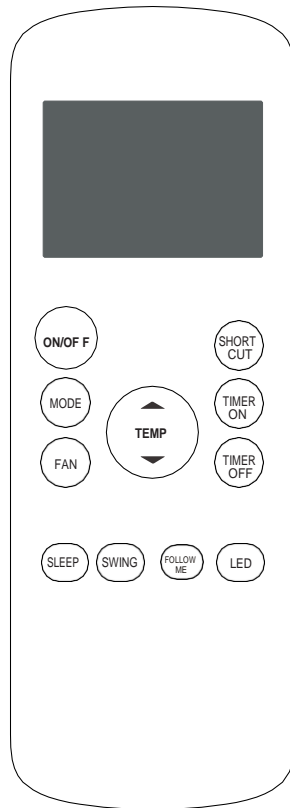

NOTE:

- Buttons design is based on typical model and might be slightly different from the actual one you purchased, the actual shape shall prevail.
- All the functions described are accomplished by the unit, if the unit is not equipped with a certain feature, there will be no corresponding action.
- When there are wide differences between Remote controller Illustration and USERS MANUAL on function description, the description on USERS MANUAL shall prevail.
- The device could comply with the local national regulations. In Canada, it should comply with CAN ICES-3(B)/NMB-3(B). In USA, this device complies with part 15 of the FCC Rules. Operation is subject to the following two conditions: (1) This device may not cause harmful interference, and (2) this device must accept any interference received, including interference that may cause undesired operation.
- This equipment has been tested and found to comply with the limits for a Class B digital device, pursuant to part 15 of the FCC Rules. These limits are designed to provide reasonable protection against harmful interference in a residential installation. This equipment generates, uses and can radiate radio frequency energy and, if not installed and used in accordance with the instructions, may cause harmful interference to radio communications. However, there is no guarantee that interference will not occur in a particular installation. If this equipment does cause harmful interference to radio or television reception, which can be determined by turning the equipment off and on, the user is encouraged to try to correct the interference by one or more of the following measures:
 - Reorient or relocate the receiving antenna.
 - Increase the separation between the equipment and receiver.
 - Connect the equipment into an outlet on a circuit different from that to which the receiver is connected.
 - Consult the dealer or an experienced radio/TV technician for help. Changes or modifications not approved by the party responsible for compliance could void users authority to operate the equipment.

The design and specifications are subject to change without prior notice for product improvement. Consult with the manufacturer for details

Function Buttons

Before you begin using your new air conditioner, make sure to familiarize yourself with the remote control. The following is a brief introduction to the remote control. For detailed instructions on operation of the air conditioner, refer to the Instruction Manual.

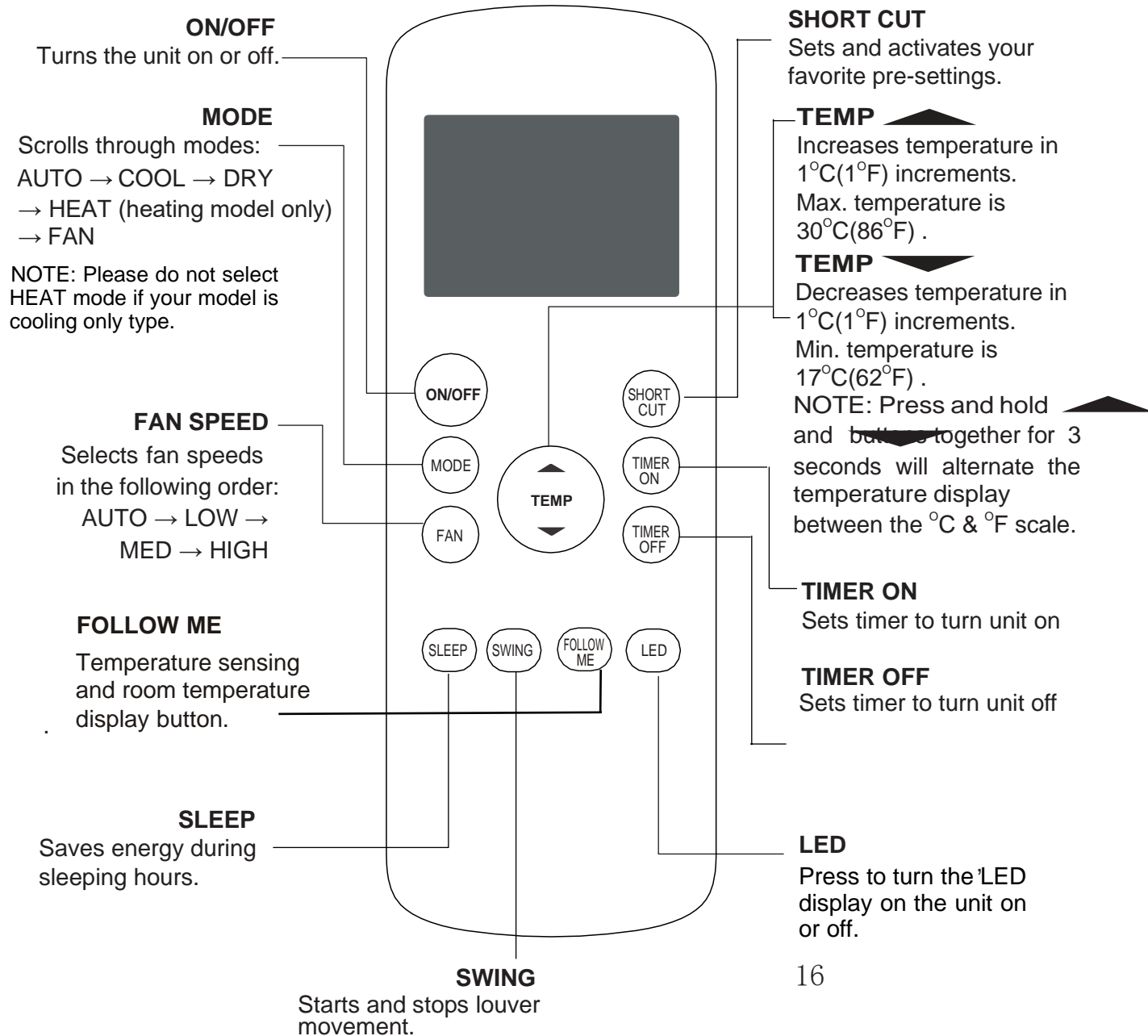

Handling the Remote Controller

NOT SURE WHAT A FUNCTION DOES?

Refer to the Operation Instructions section of this manual for a detailed description on how to use your air conditioner.

SPECIAL NOTE

Button designs on your unit may differ slightly from the example shown. When there are wide differences between Remote controller illustration and USER'S MANUAL on function description, the description of USER'S MANUAL shall prevail.

Inserting and Replacing Batteries

The remote controller is powered by two AAA batteries (not included). The batteries are housed in the back of the remote, protected by a cover.

Place batteries in the remote control before use.

1. Press down on the cover and slide it outwards to remove.
2. Insert batteries, paying attention to match the (+) and (-) ends of the batteries with the symbols inside the battery compartment.
3. Slide the battery cover back into place.

BATTERY NOTES

For optimum product performance:

Do not mix old and new batteries, or batteries of different types.

Remove batteries if the remote will not be used for more than 2 months



BATTERY DISPOSAL

Do not dispose of batteries as unsorted municipal waste. Refer to local laws for proper disposal of batteries.

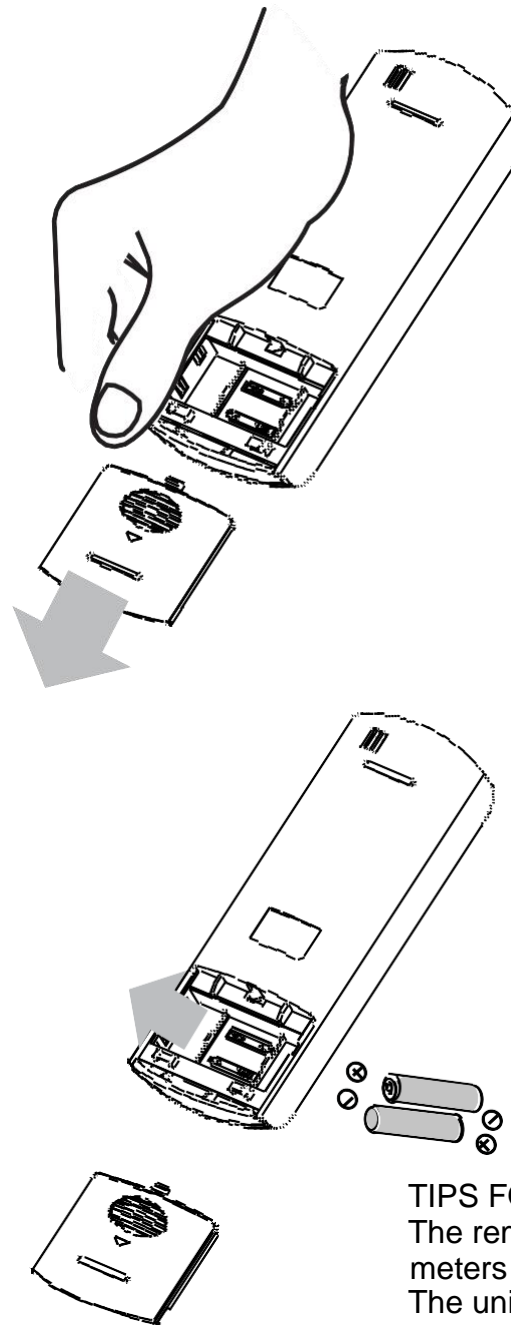

TIPS FOR USING REMOTE CONTROL
The remote control must be used within 8 meters of the unit.
The unit will beep when remote signal is received.
Curtains, doors, other barriers and direct sunlight can interfere with the infrared signal receiver.

Remote LCD Screen Indicators

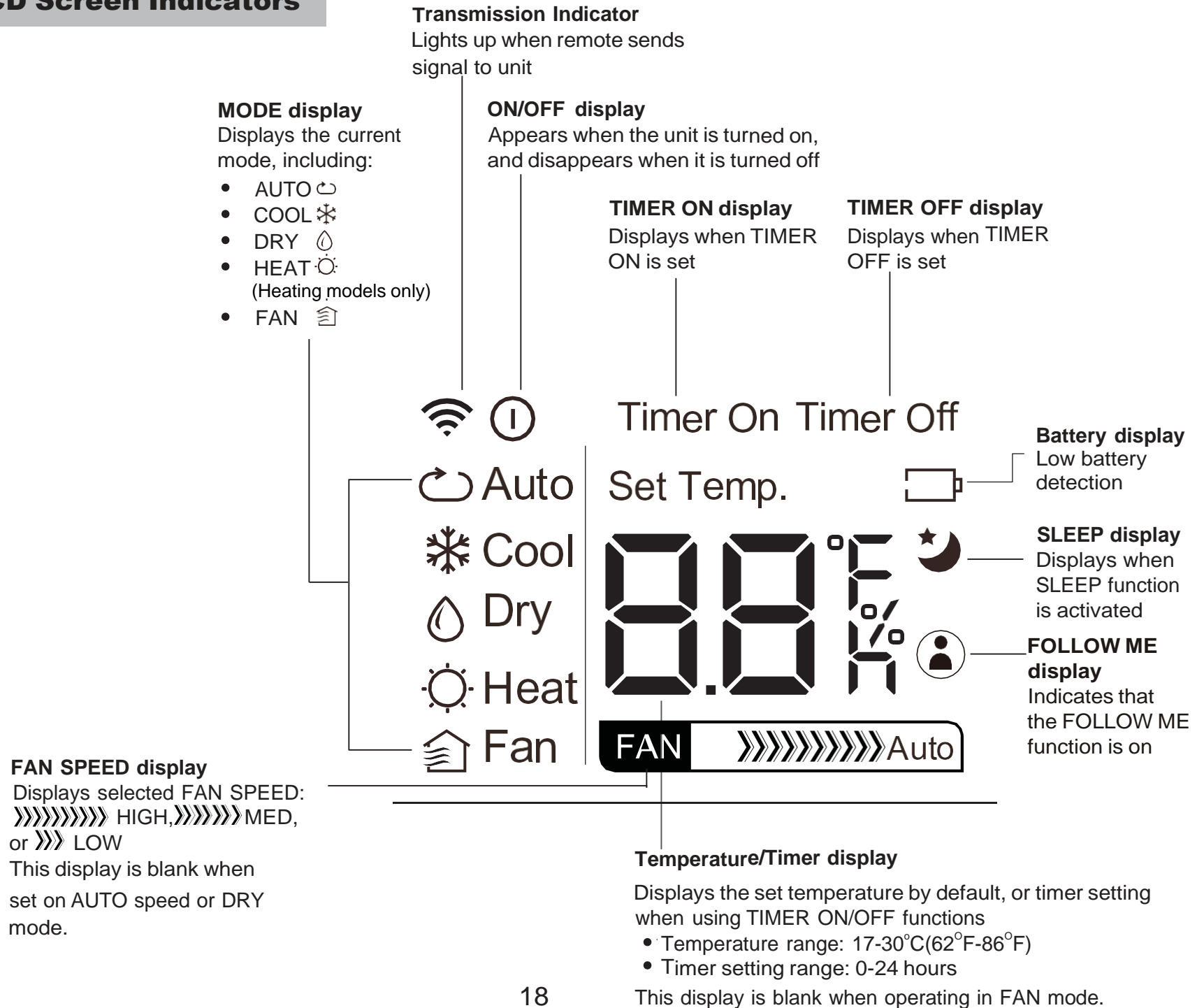

How To Use The Basic Functions

The operating temperature range for the unit is 17°C-30°C (62°F-86°F). You can increase or decrease the set temperature in 1°C(1°F) increments

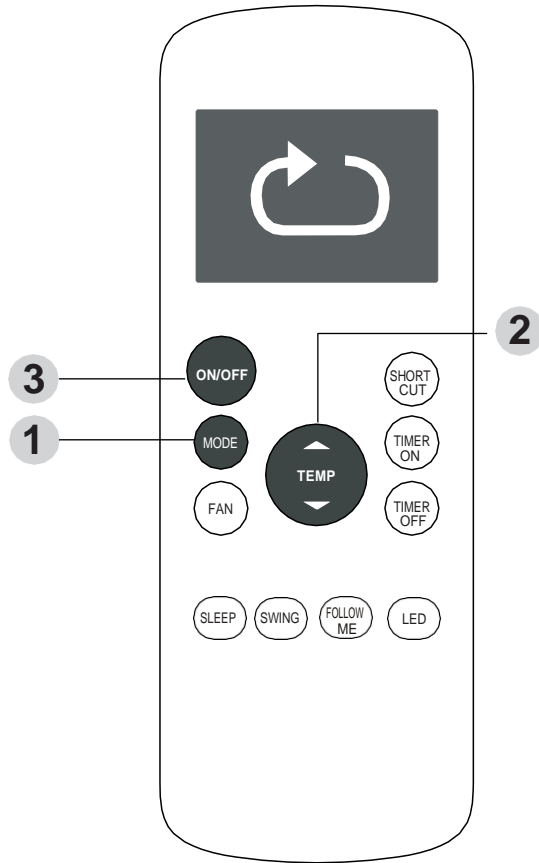

AUTO OPERATION

In AUTO mode, the unit will automatically select COOL, FAN, HEAT (heating models only), or DRY mode based on the set temperature

1. Press the **MODE** button to select Auto mode.
2. Set your desired temperature using the **Temp Up/Down** button.
3. Press the **ON/OFF** button to start the unit.

NOTE: FAN SPEED can't be set in Auto mode.

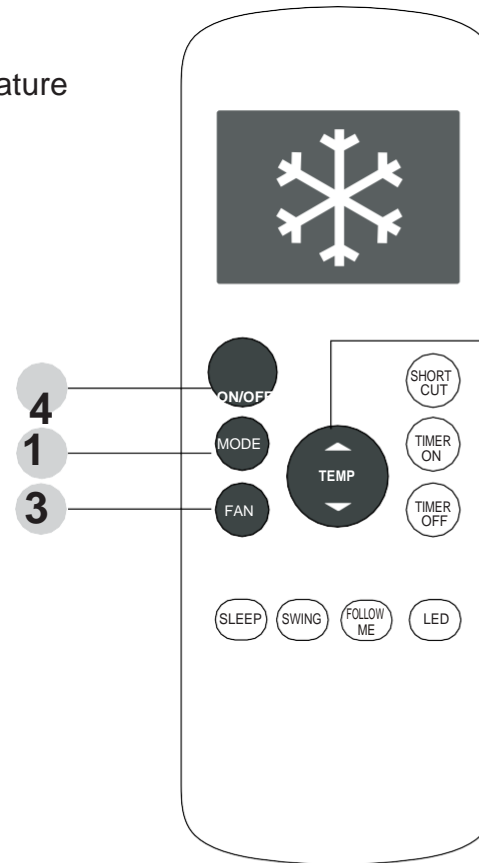

COOL OPERATION

1. Press the **MODE** button to select COOL
2. Set your desired temperature using the **Temp Up/Down** button.
3. Press the **FAN** button to select the fan speed: AUTO, LOW, MED or HIGH.
4. Press the **ON/OFF** button to start the

HEAT OPERATION

1. Press the **MODE** button to select **HEAT**.
2. Set desired temperature using the **Temp Up/Down** button.
3. Press the **FAN** button to select the fan speed: AUTO, LOW, MED, or HIGH.
4. Press the **ON/OFF** button to start.

NOTE: As outdoor temperature drops, the performance of your unit's HEAT function may be affected. In such instances, it is recommended to use this unit in conjunction with other heating appliance.

NOTE: Heat mode is for cooling & heating models only.

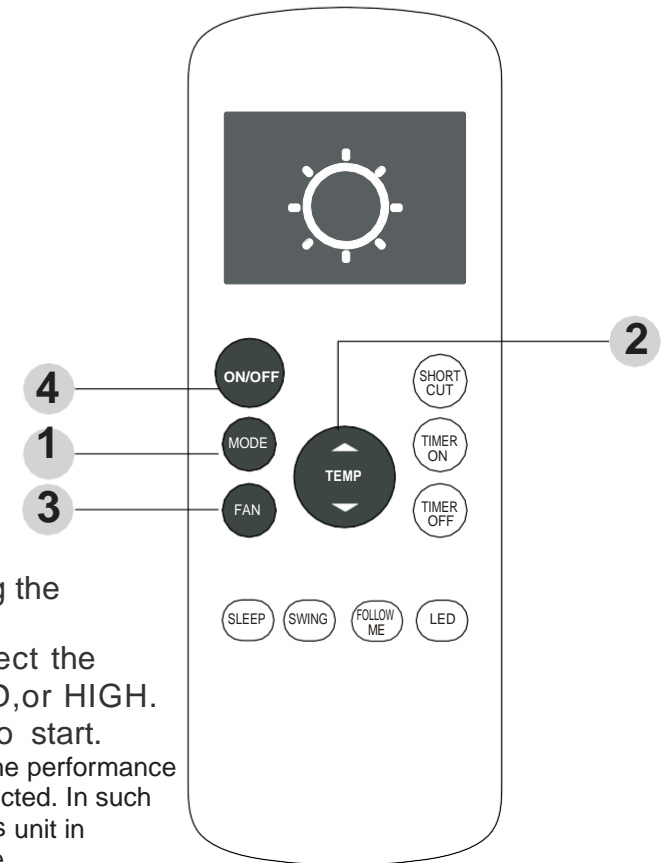

How To Use The Basic Functions

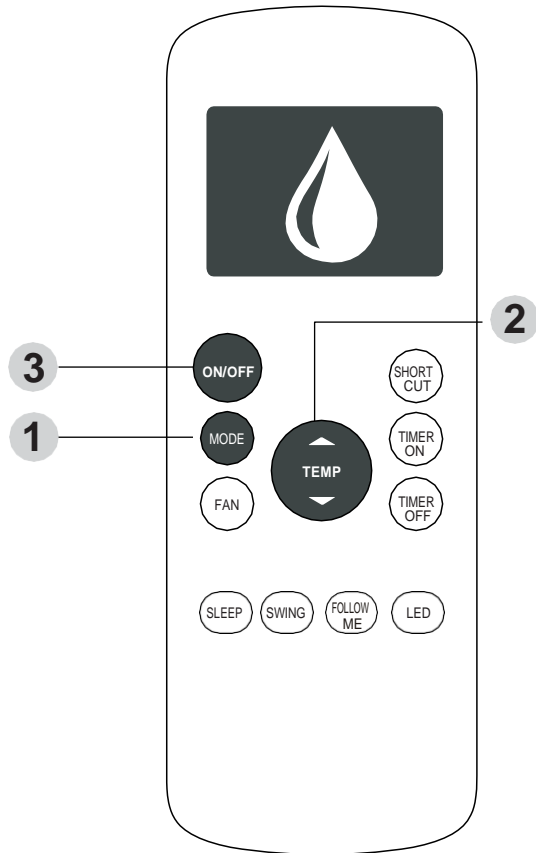

DRY OPERATION

1. Press the MODE button to select DRY mode.
 2. Set your desired temperature using the Temp Up/Down button.
 3. Press the ON/OFF button to start the unit.
- NOTE: FAN SPEED can not be changed in DRY mode.

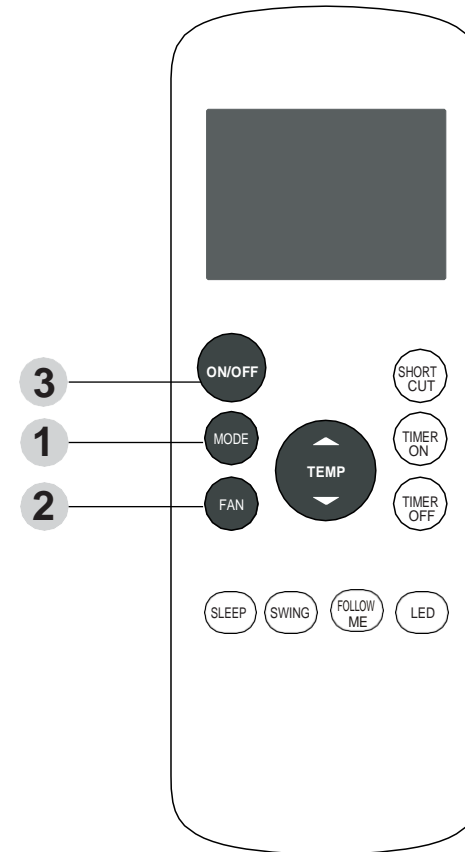

FAN OPERATION

1. Press the MODE button to select FAN mode.
2. Press FAN button to select the fan speed:
AUTO, LOW, MED or HIGH.
3. Press the ON/OFF button to start the unit.

NOTE: Temperature cannot be set in FAN mode. As a result, LCD screen will not display temperature.

Setting the Timer

Your air conditioning unit has two timer-related functions:

TIMER ON: Set the amount of time after which the unit will automatically turn on.

TIMER OFF: Set the amount of time after which the unit will automatically turn off.

TIMER ON function: Sets amount of time for unit to turn on, such as when you will return home.

- Press the **TIMER ON** button. By default, the last set time and "h" (hour) will appear on display.
- Press the **TIMER ON** button again and repeatedly to set desired time.
- When desired time is reached, release button and wait 2 seconds for **TIMER ON** to activate. Display will return to displaying temperature.

EXAMPLE: if you wish to set **TIMER ON** for 2.5 hours, press button once to initiate and 5 more times for 2.5 hours. "2.5h" will display on the screen and unit will turn on after 2.5 hours.

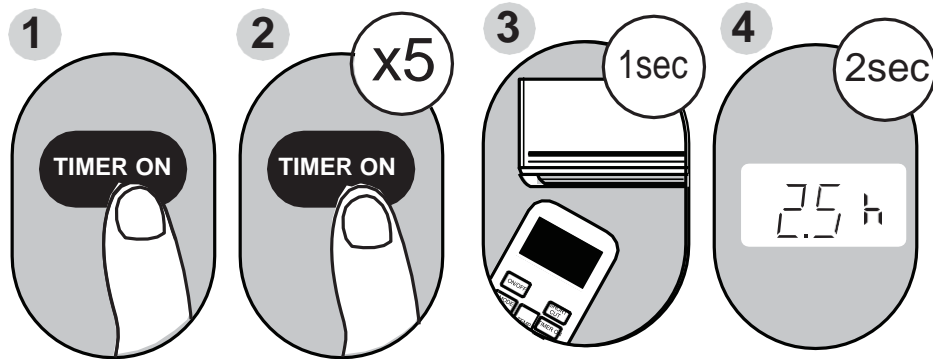

Example: Setting unit to turn on after 2.5 hours.

TIMER OFF function: Sets amount of time for unit to turn off, such as when you plan to leave.

- Press the **TIMER OFF** button. By default, the last set time and "h" will appear on display.
- Press the **TIMER OFF** button again and repeatedly to set desired time.
- When the desired time is reached, release button and wait 2 seconds for **TIMER OFF** to activate.

Display will return to displaying temperature.

EXAMPLE: if you wish to turn unit off after 5 hours.

Press **TIMER OFF** button once to initiate and press 10 more times to set 5.0 hours. "5.0h" will display on the screen and unit will turn off after 5 hours.

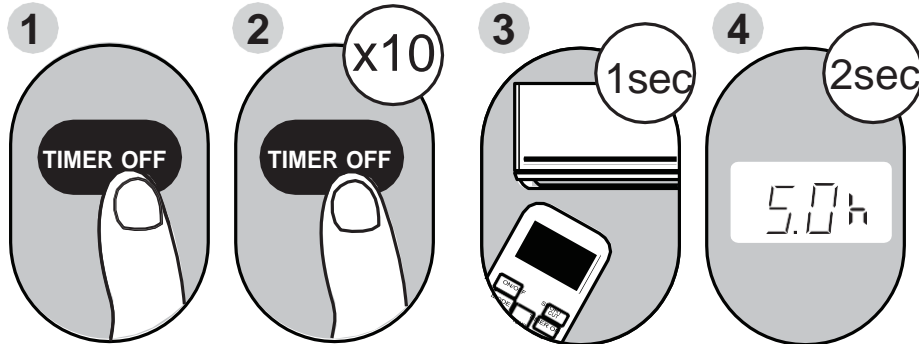

Example: Setting unit to turn off after 5 hours.

NOTE: When setting **TIMER ON** or **TIMER OFF** functions, each press of button increases the set time by 30-minutes, up to 10 hours. Then by 1-hour increments, up to 24 hours. Timer will revert to zero after 24 hours. Either timer function can be turned off by setting time to "0.0h".

Setting combined timers: TIMER ON and TIMER OFF at the same

Keep in mind that the time periods you set for both functions refer to hours after the current time. For example, say that the current time is 1:00 PM, and you want the unit to turn on automatically at 7:00 PM (which is 6 hours from current time); operate for 2 hours, then automatically turn off at 9:00 PM (which is 8 hours from current time).

Do the following:

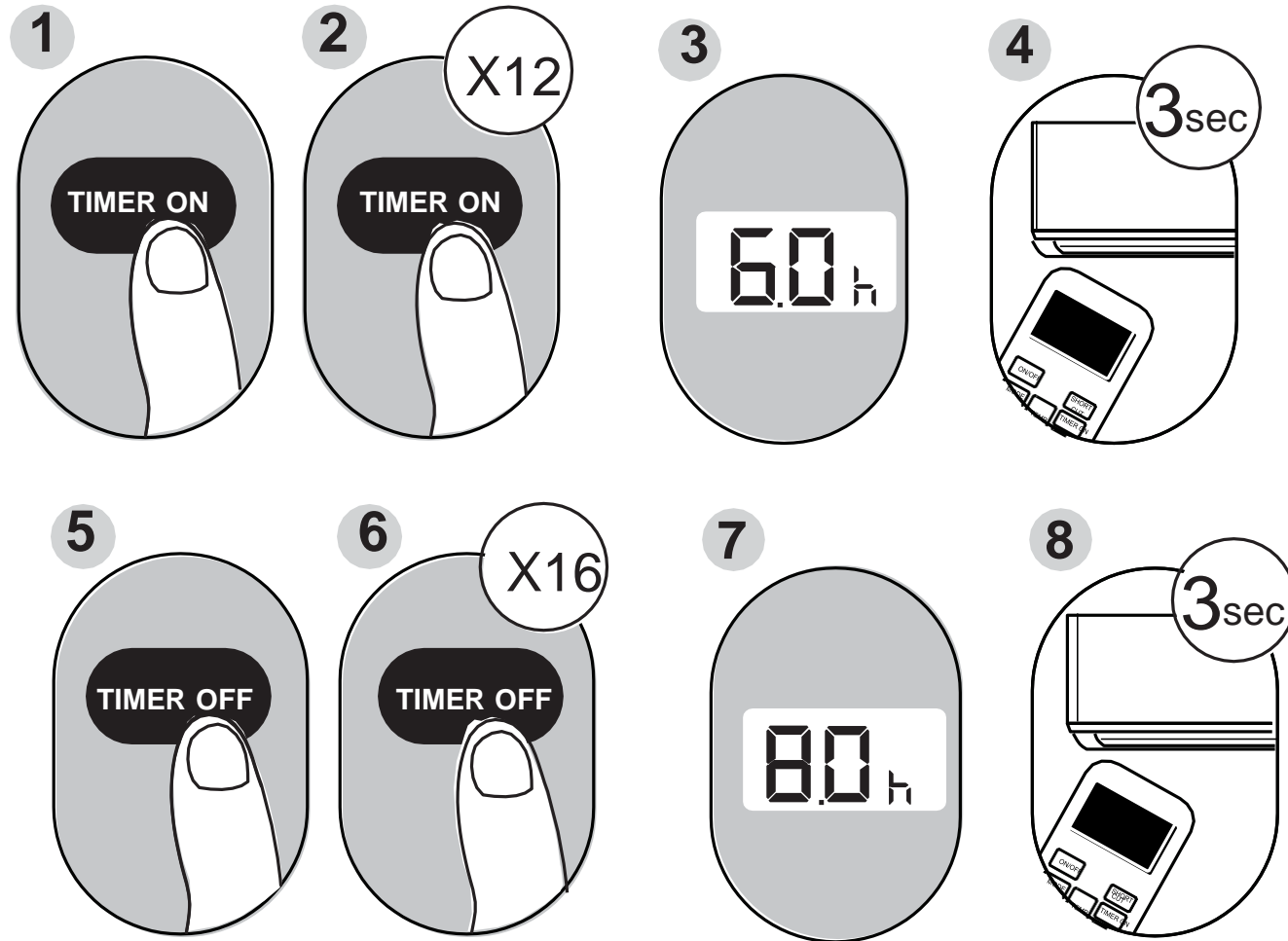

Example: Setting the unit to turn on after 6 hours, operate for 2 hours, then turn off (see the figure below).

Your remote display

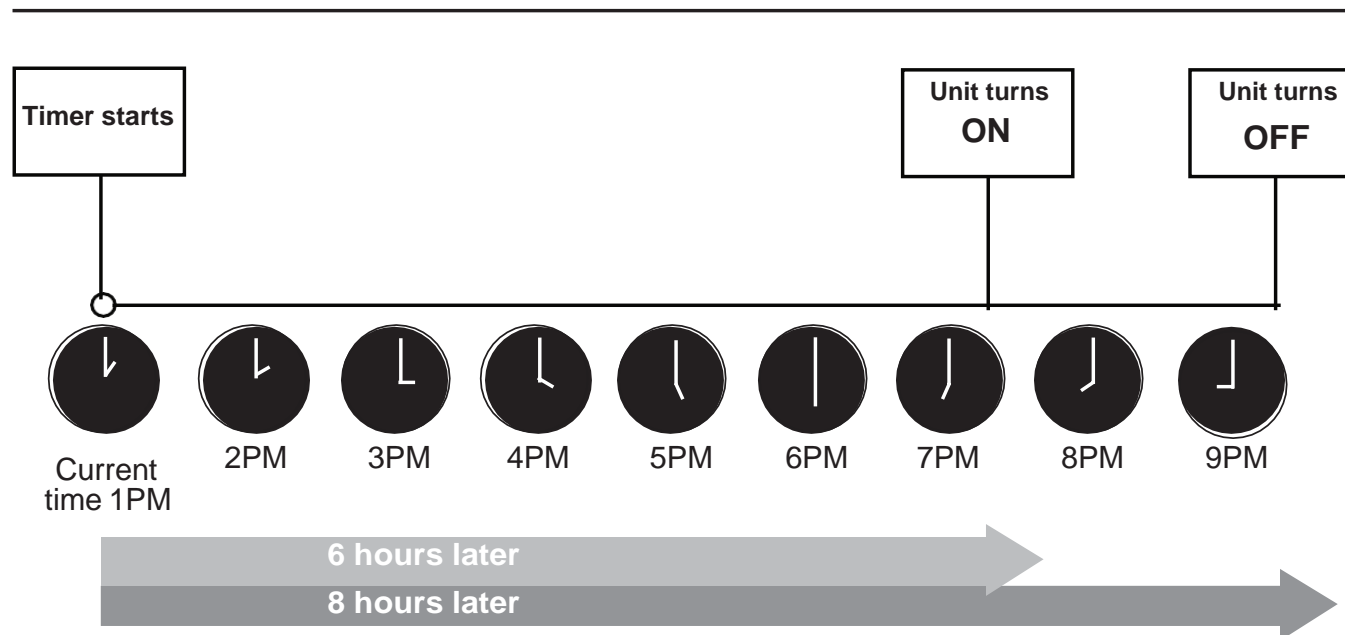
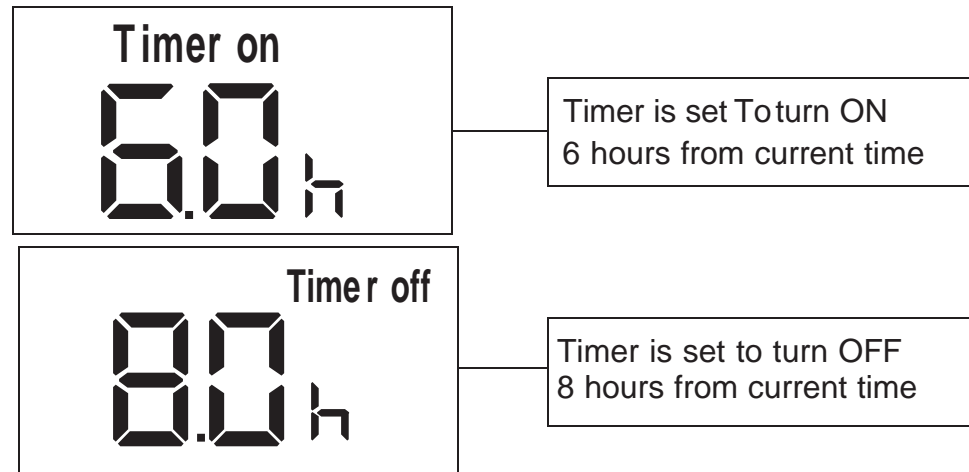

How To Use The Advanced Functions

SLEEP Function

The SLEEP function is used to conserve energy while you sleep. When activated, unit will increase set temperature by 1°C/1°F after 30 minutes; and by another 1°C/1°F after additional 30 minutes. New temperature will be maintained for 7 hours then unit returns to originally set temperature. This ends the SLEEP function.

The SLEEP function is not available in FAN or DRY mode.

SWING Function

Used to stop or start louver movement and set the desired air flow direction.

- One quick press adjusts the angle by 6°. Keep pressing to adjust to desired angle.
- Press and hold for 2 seconds to activate/deactivate auto-swing function.

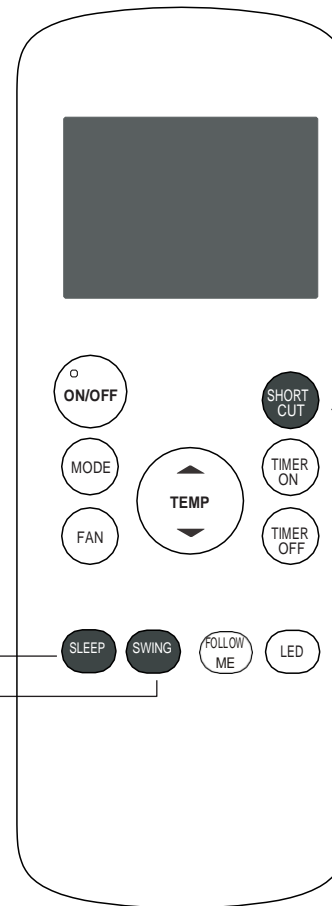

SHORTCUT function

- Used to restore the current settings or resume previous settings.
- On the first time connecting to the power, if push the SHORT CUT button, the unit will operate on AUTO mode at 26°C(79°F), and fan speed is Auto.
- Push this button when remote controller is on, the system will automatically revert back to the previous settings including operating mode, setting temperature, fan speed level and sleep feature (if activated).
- If pushing more than 2 seconds, the system will automatically restore the current operation settings including operating mode, setting temperature, fan speed level and sleep feature (if activated).

**If this product is defective
or not working properly
Please DO NOT return to your retail store**

**Please contact us directly with any
Service or Technical Assistance**

**Contact us toll free at:
1-800-330-0388**



Your Guarantee

If this product is found to be faulty as a result of faulty materials or workmanship within one year from date of purchase, it will be repaired free of charge.

This guarantee is subject to the following terms:

- Sunpentown must be notified of the fault.
- Proof of purchase must be presented to Sunpentown's nominated representative.
- The warranty will be void if the product is modified, misused or repaired by an unauthorized person.
- The warranty after repair will not be extended beyond the original one-year period.
- All replacement parts will be new or reconditioned.
- Parts, which are replaced, become the property of Sunpentown.
- The warranty applies for the use of the product in the USA only.

What is NOT COVERED:

- Warranty does not include freight charges.
- Damage due to installation error, product abuse and/or misuse.
- Incidental or consequential damage caused by possible defects with this product.
- Labor cost incurred for the installation and/or removal of a possible defective unit.
- Damage to product caused by improper power supply voltage, accident, fire, floods or acts of nature.
- Failure of product resulting from unauthorized modifications to the product.
- Improper installation or failure to perform the necessary maintenance.
- Normal wear and tear on parts or replacement of parts designed to be replaced.
- Damage to personal property from use of product.
- Replacement or repair of household fuses, circuit breakers, wiring or plumbing.

This GUARANTEE is in addition to your Statutory Rights

SUNPENTOWN INTERNATIONAL INC.
14625 Clark Ave. City of Industry, CA 91745
Tel: 800-330-0388
service@sunpentown.com
www.sunpentown.com