



These universal heat-circulating vent-free fireboxes offer 24" tall hooded clean-faced openings that complement current trends in home design.

FEATURES

- 🔥 Available in 36" and 42" clean-faced heat-circulating models
- 🔥 24" tall and full width refractory opening on all models
- 🔥 Stacked refractory liners (sides and back only)
- 🔥 Includes heat deflection hood
- 🔥 Durable textured powder coat finish
- 🔥 Includes mesh fire screens
- 🔥 Select from a variety of compatible vent-free log sets and controls (sold separately)
- 🔥 Optional precision-cut decorative twin-pane screen doors in a textured iron finish
- 🔥 Optional blower kits available for all models
- 🔥 Optional outside air kit
- 🔥 20-year limited warranty

INTERIOR PANEL



Stacked Refractory Liners

COMPATIBLE VF GAS LOG SETS



Crescent Hill



Crescent Hill HD



Golden Oak



Boulder Mountain



Rugged Stack



Wild Timber

Compatible with any listed ANSI Z21.11.2 vent-free log set. Choose a Superior vent-free log set for best results.

APPLIANCE SPECIFICATIONS

OPTIONAL ACCESSORIES

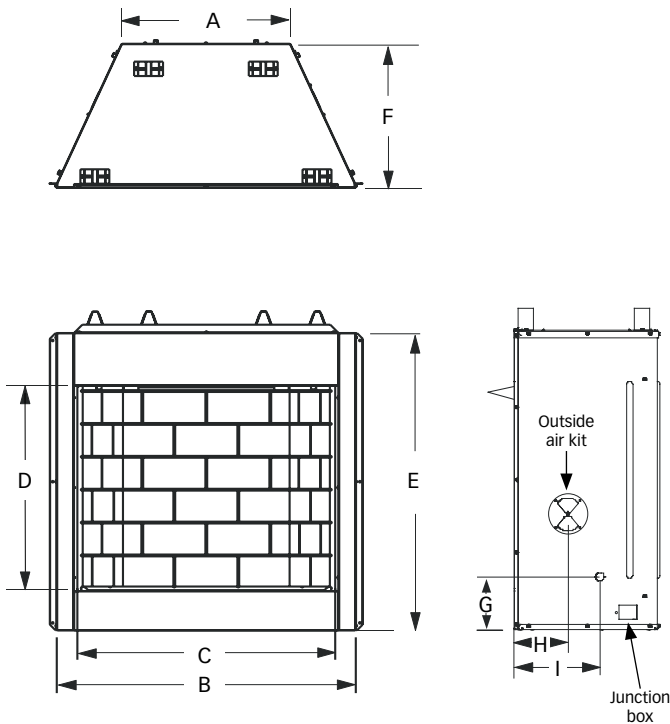

- Decorative twin-pane screen door in a textured iron finish
- Single and variable speed blower kits
- Outside air kits
- Vent-free gas logs

FRAMING SPECIFICATIONS

	VRT2536	VRT2542
A	23-1/2"	29-1/2"
B	41-3/4"	47-3/4"
C	36"	42"
D	24"	24"
E	37-1/4"	37-1/4"
F	20"	20"
G	7-3/8"	7-3/8"
H	7-1/2"	7-1/2"
I	12"	12"

	VRT2536	VRT2542
A	42-1/4"	48-1/4"
B	40-1/4"	40-1/4"
C	20-1/2"	20-1/2"

INTERIOR FIREBOX DIMENSIONS*

	VRT2536	VRT2542
FRONT WIDTH	35"	41"
REAR WIDTH	23-1/4"	29-1/4"
DEPTH	17-3/8"	17-3/8"
HEIGHT	24"	24"

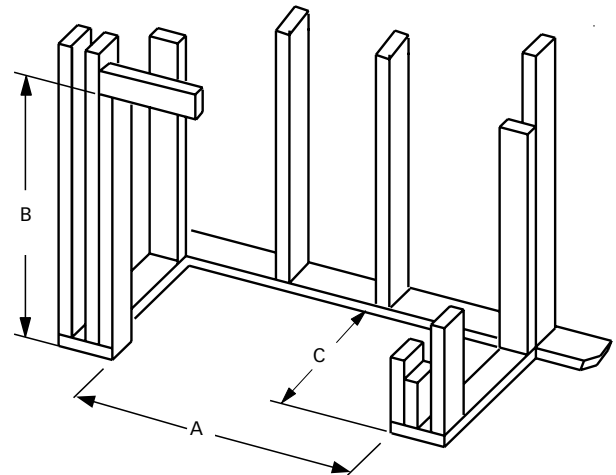

* To assist with compatible log size selection

On the Cover: VRT2536 shown with Refractory Liner and Crescent Hill Vent-Free Logs (sold separately).

IMPORTANT NOTES:

As with any fireplace, this appliance is extremely hot during operation. Read and understand all operating instructions before using this appliance. For further information, consult your dealer.

Local conditions, such as elevation, wind, vent configuration and choice of fuel will affect overall appearance of the fire and heating performance. Performance can also vary with home design and insulation, climate, condition and type of fuel used, appliance location, burn rate, accessories chosen, chimney installation and how the appliance is operated.

Diagrams, illustrations and photographs are not to scale—consult installation instructions. Product designs, materials, dimensions, specifications, colors and prices are subject to change or discontinuance without notice.



© 2023 Innovative Hearth Products
785694M 09/23

Visit us online
SuperiorFireplaces.us.com



Report #F14-168