

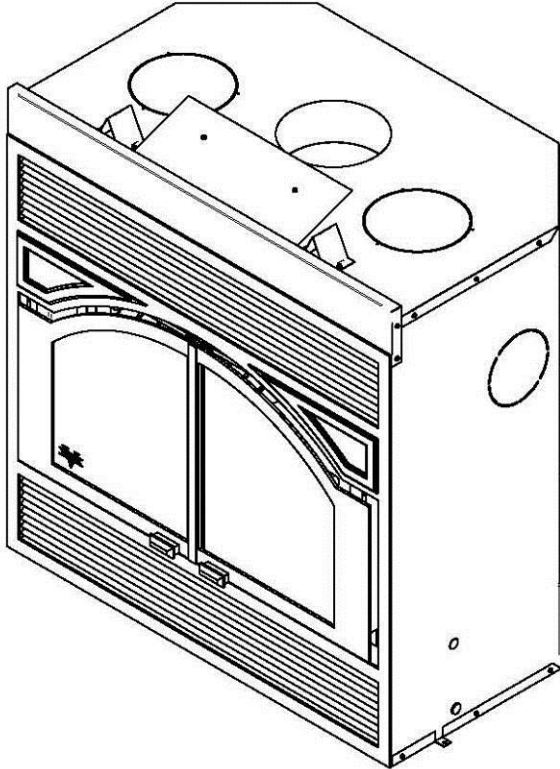

INSTALLATION AND OPERATION MANUAL

ME300 (VB00001 model)



**U.S. EPA Low Mass Wood-burning
Fireplace voluntary program phase 2
emission level qualified model**

This model is
EPA QUALIFIED
Under the LOW MASS
Wood-Burning Fireplace Program **PHASE 2** EMISSION LEVEL

Safety tested according to ULC-S610
and UL 127 Standards
by an accredited laboratory

www.occanada.com

Manufactured by:

Stove Builder International Inc.

250 rue Copenhagen, Saint-Augustin-de-Desmaures (Quebec), Canada, G3A 2H3

After-sale service: 418-908-8002 E-mail: tech@sbi-international.com

READ AND KEEP THIS MANUAL FOR REFERENCE



This manual is available for free download on the manufacturer's web site. It is a copyrighted document. Re-sale is strictly prohibited. The manufacturer may update this manual from time to time and cannot be responsible for problems, injuries, or damages arising out of the use of information contained in any manual obtained from unauthorized sources.

THANK YOU FOR CHOOSING THIS VENTIS FIREPLACE

As one of North America's largest and most respected wood stove and fireplace manufacturers, Stove Builder International takes pride in the quality and performance of all its products. We want to help you get maximum satisfaction as you use this product.

In the pages that follow you will find general advice on wood heating, detailed instructions for safe and effective installation, and guidance on how to get the best performance from this fireplace as you build and maintain fires, and maintain your wood heating system.

We recommend that our woodburning hearth products be installed and serviced by professionals who are certified in the United States by NFI (National Fireplace Institute®) or in Canada by WETT (Wood Energy Technical Training) or in Quebec by APC (Association des Professionnels du Chauffage).

Congratulations on making a wise purchase.

Read this entire manual before you install and use your new fireplace. It is important that you follow the installations guidelines exactly. Failure to install this fireplace correctly could result in a house fire, bodily injury or even death.

You may need to obtain a building permit for the installation of this fireplace and the chimney that it is connected to. Consult your municipal building or fire department about installation requirements in your area. We recommend that you also inform your home insurance company to find out if the installation will affect your policy.

PLEASE NOTE THAT THE PICTURES SHOWN IN THIS MANUAL ARE GENERIC AND MAY NOT MATCH EXACTLY THE LOOK OF YOUR FIREPLACE.

WARNING:

THE INFORMATION GIVEN ON THE CERTIFICATION LABEL AFFIXED TO THE APPLIANCE ALWAYS OVERRIDES THE INFORMATION PUBLISHED, IN ANY OTHER MEDIA (OWNER'S MANUAL, CATALOGUES, FLYERS, MAGAZINES AND/OR WEB SITES).

CAUTION: DO NOT ATTEMPT TO MODIFY OR ALTER THE CONSTRUCTION OF THE FIREPLACE OR ITS COMPONENTS. ANY MODIFICATION OR ALTERATION OF CONSTRUCTION MAY VOID THE WARRANTY, LISTINGS AND APPROVALS OF THIS SYSTEM. IN THAT CASE, STOVE BUILDER INTERNATIONAL (SBI) WILL NOT BE RESPONSIBLE FOR DAMAGES. INSTALL THE FIREPLACE ONLY AS DESCRIBED IN THESE INSTRUCTIONS.

Table of Content

PART A – INSTALLATION	5
1 Safety	5
1.1 Safety Information	5
1.1.1 Regulations Covering Fireplace Installation	6
2 General Information	7
2.1 ME300 Wood Fireplace Specifications.....	7
2.2 The Benefits of EPA Voluntary Emission Program «Low Mass» Phase II	9
3 Installation	10
3.1 Fireplace Installation.....	10
3.1.1 Installation of a Gas Log Set	10
3.2 Locating the ME300 Wood Fireplace.....	10
3.3 Raised base installation.....	11
3.4 R-Value Calculations.....	15
3.5 Minimum Hearth Extension Requirements	17
3.6 Framing, Facing, Mantel, and Combustible Shelf	18
3.6.1 Framing.....	18
3.7 Facing	22
3.8 Compliance of a Combustible Mantel Shelf.....	23
3.9 Fresh Air Intake Kit.....	24
3.10 Installation of a Gas Lighter	26
3.11 Faceplate Installation VBA1520 (Sold Separately).....	26
3.12 The Use of the Fire Screen	27
4 Venting System	28
4.1 General Information	28
4.2 Suitable Chimney	28
4.3 Chimney Installation Notes.....	29
4.4 Chimney Installation Instructions	32
4.4.1 Examples of Typical Chimney Installation	32
4.5 Offset Chimney Installation	36
4.5.1 Angled Wall Radiation Shield	37
4.6 Chimney Support Installation	37
4.6.1 Universal Roof Support	37
4.6.2 Universal Offset Support	37

PART B - OPERATION AND MAINTENANCE	38
5 Fuel.....	38
5.1 The Use of Manufactured Logs	38
6 Operating the ME300 Wood Fireplace	39
6.1 First Fires	39
6.2 Building a Fire.....	39
6.3 Maintaining the Fire.....	39
6.4 Air Intake Control and Exhaust Damper	40
6.5 Smoking – Causes and Troubleshooting.....	40
7 Maintaining Your ME300 Wood Fireplace	42
7.1 Creosote – Formation and Need for Removal	42
7.2 Chimney Maintenance	42
7.3 Dealing With a Chimney Fire.....	42
7.4 Disposal of Ashes	43
7.5 Refractory Panel Replacement	43
7.6 Replacing the Glass and/or the Glass Gasket	45
7.7 Plated Finish Maintenance.....	46
7.8 Glass Care – Cleaning.....	46
7.9 Blower Maintenance or Replacement	47
Appendix 1: Optional Heat Distribution Systems Installation (AC01375, AC01376 or AC01340)	49
Appendix 2: Exploded Diagram and Parts List	59
VENTIS LIMITED LIFETIME WARRANTY	62

REGISTER YOUR WARRANTY ONLINE

To receive full warranty coverage, you will need to show evidence of the date you purchased your unit. Keep your sales invoice. We also recommend that you register your warranty online at <http://www.occanada.com/en/service-support/warranty-registration>
 Registering your warranty online will help us track rapidly the information we need on your unit.

PART A – INSTALLATION

THE INFORMATION GIVEN ON THE CERTIFICATION LABEL AFFIXED TO THE APPLIANCE ALWAYS OVERRIDES THE INFORMATION PUBLISHED, IN ANY OTHER MEDIA (OWNER’S MANUAL, CATALOGUES, FLYERS, MAGAZINES AND/OR WEB SITES).

1 SAFETY

1.1 Safety Information

CAUTION: NEVER USE GASOLINE, GASOLINE-TYPE LANTERN FUEL, KEROSENE, CHARCOAL LIGHTER FLUID OR SIMILAR LIQUIDS TO START OR “FRESHEN UP” A FIRE IN THIS FIREPLACE. KEEP ALL SUCH LIQUIDS WELL AWAY FROM THE FIREPLACE AT ALL TIMES.

CAUTION: KEEP COMBUSTIBLE MATERIALS AT LEAST 48 INCHES AWAY FROM THE FRONT OF THE FIREPLACE OPENING.

CAUTION: NEVER LEAVE CHILDREN UNATTENDED WHEN THERE IS A FIRE BURNING IN THE FIREPLACE.

CAUTION: NEVER USE GRATE OR ELEVATE FIRE. BUILD WOOD FIRE DIRECTLY ON HEARTH.

CAUTION: DO NOT USE A FIREPLACE INSERT AND OTHER PRODUCTS NOT SPECIFIED FOR USE WITH THIS FIREPLACE.

CAUTION: DO NOT OBSTRUCT AIR INTLETS. THIS FIREPLACE NEEDS AIR FOR ITS GOOD OPERATION.

WARNING: THIS FIREPLACE HAS NOT BEEN TESTED WITH A GAS LOG LIGHTER.

WARNING: DO NOT USE MATERIAL OTHER THAN THOSE LISTED IN THE REPLACEMENT PARTS SECTION DURING INSTALLATION AS THEY MAY BE SAFETY HAZARDS AND A FIRE COULD RESULT.

CAUTION: FOR SAFETY REASONS, IT IS VERY IMPORTANT TO USE A NON-COMBUSTIBLE MATERIAL FOR THE SURROUND OF THE FIREPLACE. IN THAT CASE, A CEMENT-BOARD (DUROCK STYLE) IS MANDATORY. FAILING TO RESPECT THIS GUIDELINE MAY RESULT IN A FIRE.

CAUTION: THIS HEATING UNIT MUST SERVE AS A SUPPLEMENTARY HEAT SOURCE. AN ALTERNATIVE HEAT SOURCE SHOULD BE AVAILABLE IN THE HOME IF NEEDED. THE MANUFACTURER CANNOT BE RESPONSIBLE FOR ADDITIONAL HEATING COSTS ASSOCIATED WITH THE USE OF AN ALTERNATIVE HEAT SOURCE. IT IS HIGHLY RECOMMENDED THAT THE USER BUYS THIS PRODUCT FROM A RETAILER WHO CAN PROVIDE INSTALLATION AND MAINTENANCE ADVICES.

CAUTION: DO NOT CONNECT THIS UNIT TO A CHIMNEY FLUE SERVING ANOTHER APPLIANCE.

CAUTION: DO NOT INSTALL THIS FIREPLACE IN A MOBILE HOME.



WARNING: This product can expose you to chemicals including carbon monoxide, which is known to the State of California to cause cancer, birth defects or other reproductive harm. For more information go to www.P65warnings.ca.gov/

CAUTION: OPERATE ONLY WITH GLASS DOORS FULLY CLOSED OR FULLY OPEN WITH MECHE DOORS ALWAYS CLOSED. IF DOORS ARE LEFT PARTLY OPEN, GAS AND FLAME MAY BE DRAWN OUT OF THE OPENING, CREATING RISKS FROM BOTH FIRE AND SMOKE. NEVER LEAVE THE FIREPLACE UNATTENDED WHEN IN USE.

WARNING: THIS FIREPLACE HAS BEEN TESTED FOR USE WITH OPEN DOORS IN CONJUNCTION WITH MECHE DOORS ALWAYS CLOSED. THE MECHE DOORS MAY BE OPENED ONLY DURING LIGHTING PROCEDURES OR RELOADING. ALWAYS CLOSE THE MECHE DOORS AFTER IGNITION.

WARNING: THIS FIREPLACE HAS NOT BEEN TESTED TO BE INSTALLED INSIDE A MASONRY CHIMNEY.

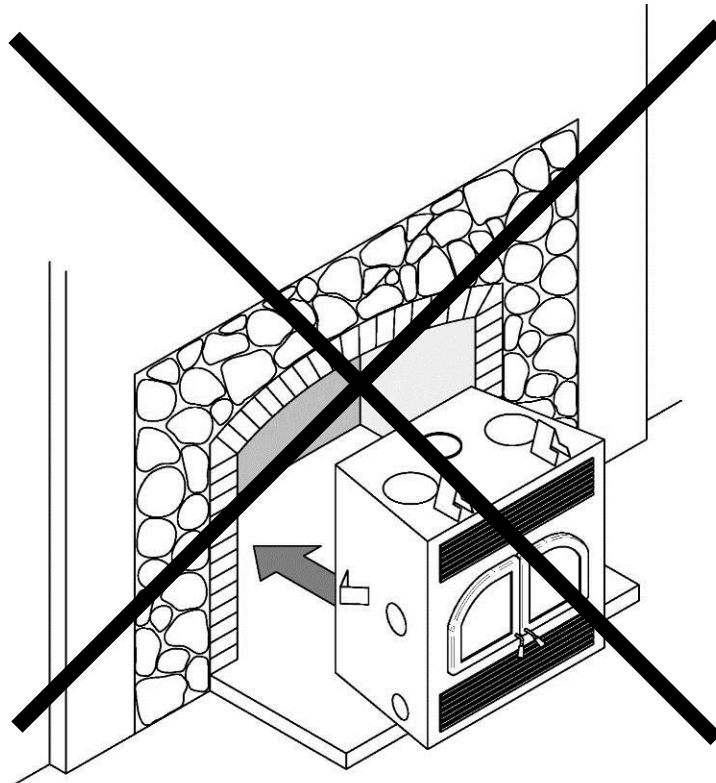

1.1.1 Regulations Covering Fireplace Installation

When installed and operated as described in these instructions, the ME300 wood fireplace is suitable for use as a fireplace appliance in residential installations.

In Canada, the CSA B365 Installation Code for Solid Fuel Burning Appliances and Equipment and the CSA C22.1 Canadian National Electrical Code are to be followed in the absence of local code requirements. In the USA, the NFPA 211 Standard for Chimneys, Fireplaces, Vents and Solid Fuel-Burning Appliances and the ANSI NFPA 70 National Electrical Code are to be followed in the absence of local code requirements.

NOTE: The Fireplace is not approved for use with a so-called “positive flue connection” to the clay tile of a masonry chimney.

2 GENERAL INFORMATION

2.1 ME300 Wood Fireplace Specifications

Fuel Type	Cordwood
Test Standards (safety)	ULC-S610 and UL 127
Test Standard (emissions)	ASTM 2515 and ASTM 2558 to comply with U.S. EPA Low Mass Wood-burning Fireplace voluntary program phase 2 emission level qualified model
Recommended Heating Area	< 1,500 sq. ft. (< 139 m ²)
Minimum burn rate	> 5 kg/h (> 11 lb/h)
Shipping Weight	511 lb (232 kg)
Firebox Volume	4.25 cu.ft. (0.120 m ³)
Maximum Log Length	20" east-west
Flue Outlet Diameter	8" (203 mm) diameter (vertical)
Mobile home approved	No

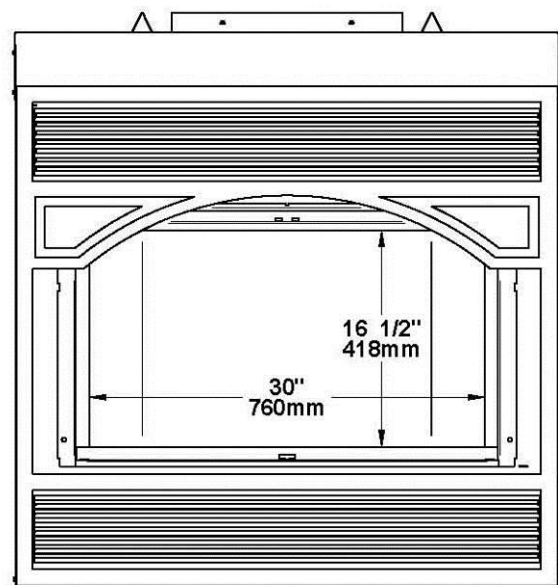
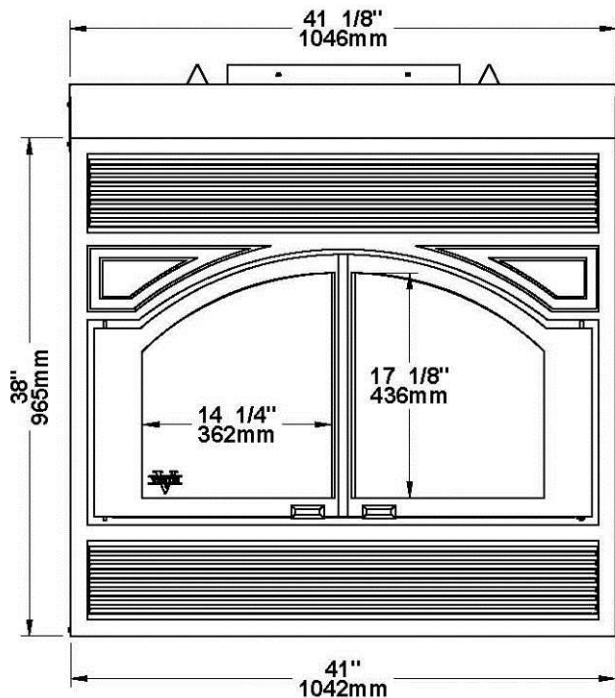

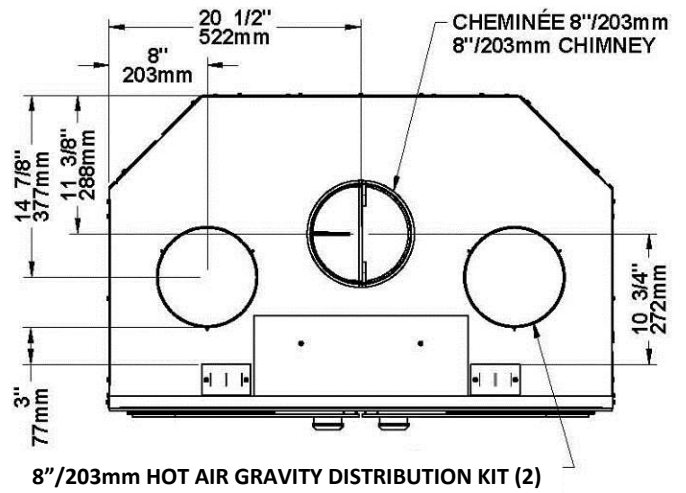
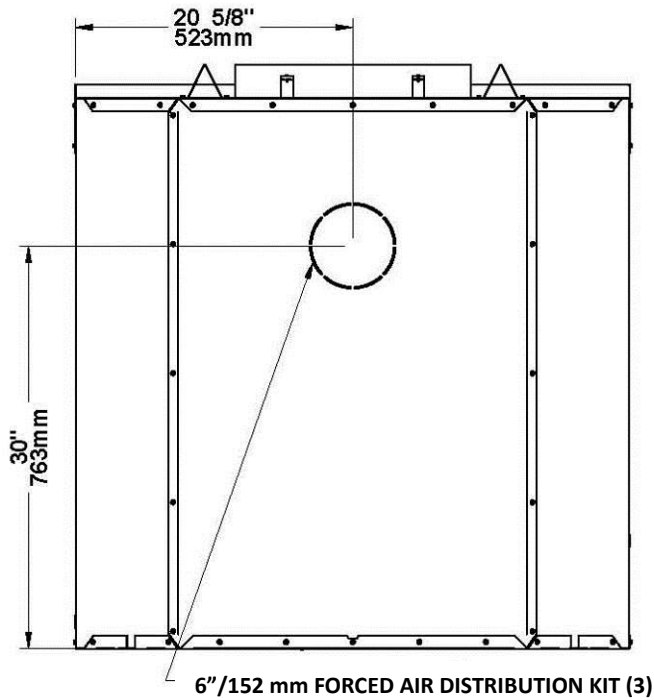
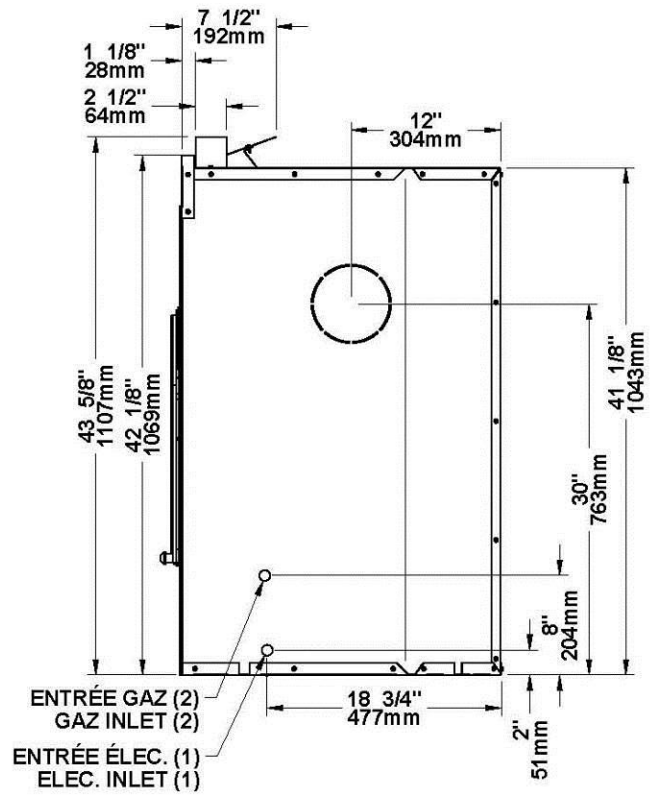
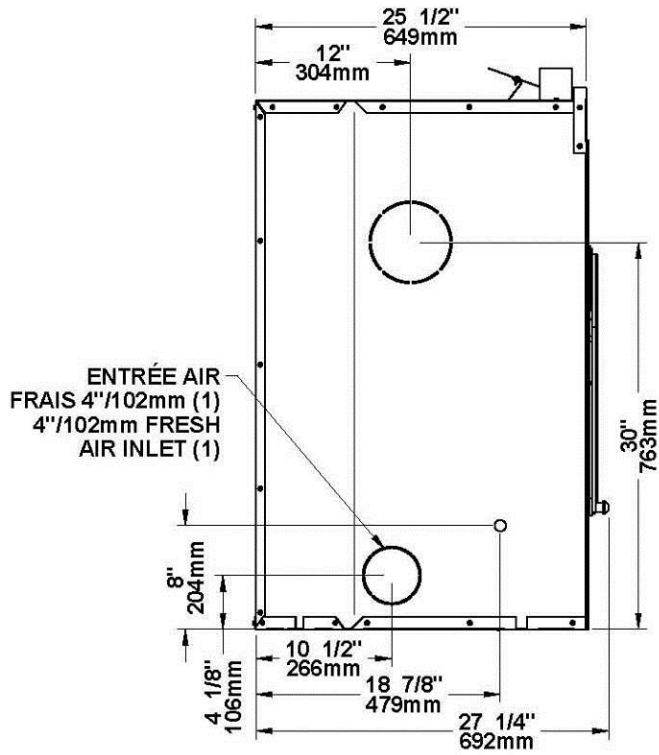

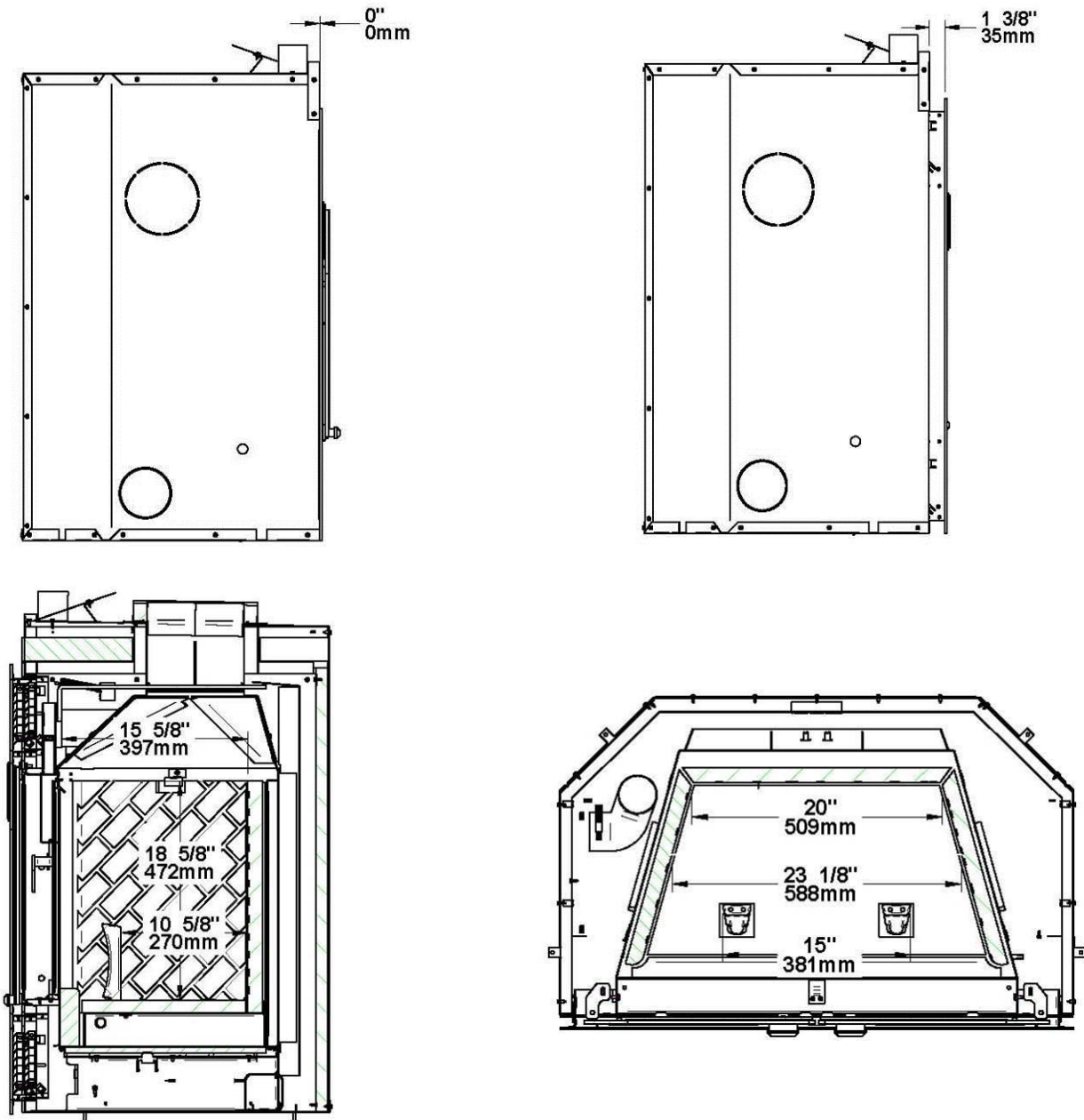

2.2 The Benefits of EPA Voluntary Emission Program «Low Mass» Phase II

In the past, most conventional masonry and low-mass, factory-built fireplaces were not efficient at producing usable heat. Typically, over 90 percent of the heat generated by a fireplace was lost out the chimney. In addition, many of these fireplaces were sources of smoke, indoors and out.

In 2009, the US Environmental Protection Agency (EPA) initiated a voluntary program for manufacturers of decorative wood burning fireplaces to encourage manufacturers to produce clean wood-burning appliances that reduce air pollution. Under the U.S. EPA Low Mass Fireplace Voluntary Program, cleaner burning fireplaces are ones that qualify for the Phase I emission levels of 7.3 g/kg (approximately 57 percent cleaner than unqualified models) or the Phase II emission levels of 5.1 g/kg (approximately 70 percent cleaner than unqualified models). Participating manufacturers are expected to qualify under Phase 2 by 2013. The ME300 wood fireplace is a phase II emission level qualified model that brings you the benefits of lower emissions.

3 INSTALLATION

3.1 Fireplace Installation

CAUTION: BEFORE CLOSING THE WALLS, MAKE SURE THAT THE AIR CONTROL MECHANISM, THE FLUE DAMPER AND DOORS MECHANISM WORK PROPERLY.

3.1.1 Installation of a Gas Log Set

You can install a decorative gas appliance or a vented gas log set in the hearth. To do this, install an automatic shut-off valve. Comply with the Standard for Decorative Gas Appliances for Installation in Vented Fireplaces, ANSI Z21.60 (1991) or American Gas Association draft requirements for Gas-Fired Log Lighters for Wood Burning Fireplaces, Draft No. 4 dated August, 1993.

WARNING: THIS FIREPLACE HAS NOT BEEN TESTED WITH AN UNVENTED GAS LOG SET. TO REDUCE RISK OF FIRE OR INJURY, DO NOT INSTALL AN UNVENTED GAS LOG SET INTO THIS FIREPLACE.

3.2 Locating the ME300 Wood Fireplace

- A. The best location to install your fireplace is determined by considering the location of windows, doors, and the traffic flow in the room where the fireplace is located, allowing space in front of the unit for the hearth extension and the mantel, and taking into consideration the location of the fresh air intake kit and chimney. If possible, you should choose a location where the chimney will pass through the house without cutting floor or roof rafters. Also choose a location that allows installing the least amount of offsets in the chimney.
- B. Usually, no additional floor support is needed for the fireplace. The adequacy of the floor can be checked by first estimating the weight of the fireplace system. Weights are given in the **Section 2.1: ME300 Wood Fireplace Specifications**. Next, measure the area occupied by the fireplace which is normally 41 1/8" x 25 5/8" (105 cm x 65 cm). Note the floor construction and consult your local building code to determine if additional support is needed.

WARNING: THE FIREPLACE MUST BE INSTALLED ON A LEVEL AND STRAIGHT (NOT UNEVEN) SURFACE.

3.3 Raised base installation

The ME300 fireplace may be installed directly on the floor or on a raised combustible or non combustible base. However, the upper and lower angle, for the full width of the floor protection, must be protected 2" horizontally and vertically (E) by a non-combustible material. For example, a sheet metal (not included). Apart from these two corners, the sheet metal does not have to cover the rest of the wall between the base of the fireplace and the floor.

Note that the non-combustible hearth extension floor area must extend at least 16" (41 cm) in front of the hearth as shown in **Section 3.5: Minimum Hearth Extension Requirements**.

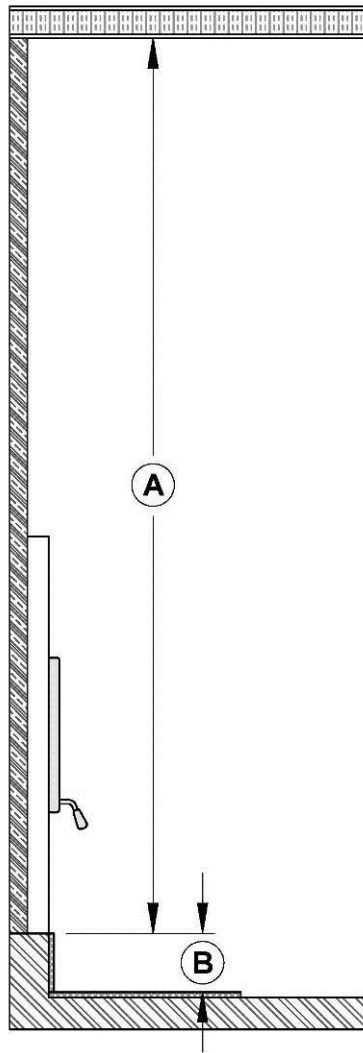

	CLEARANCES	MINIMUM MEASUREMENTS	
A	72" (1829 mm)	E	2" (51 mm)
B	12" (305 mm) maximum		

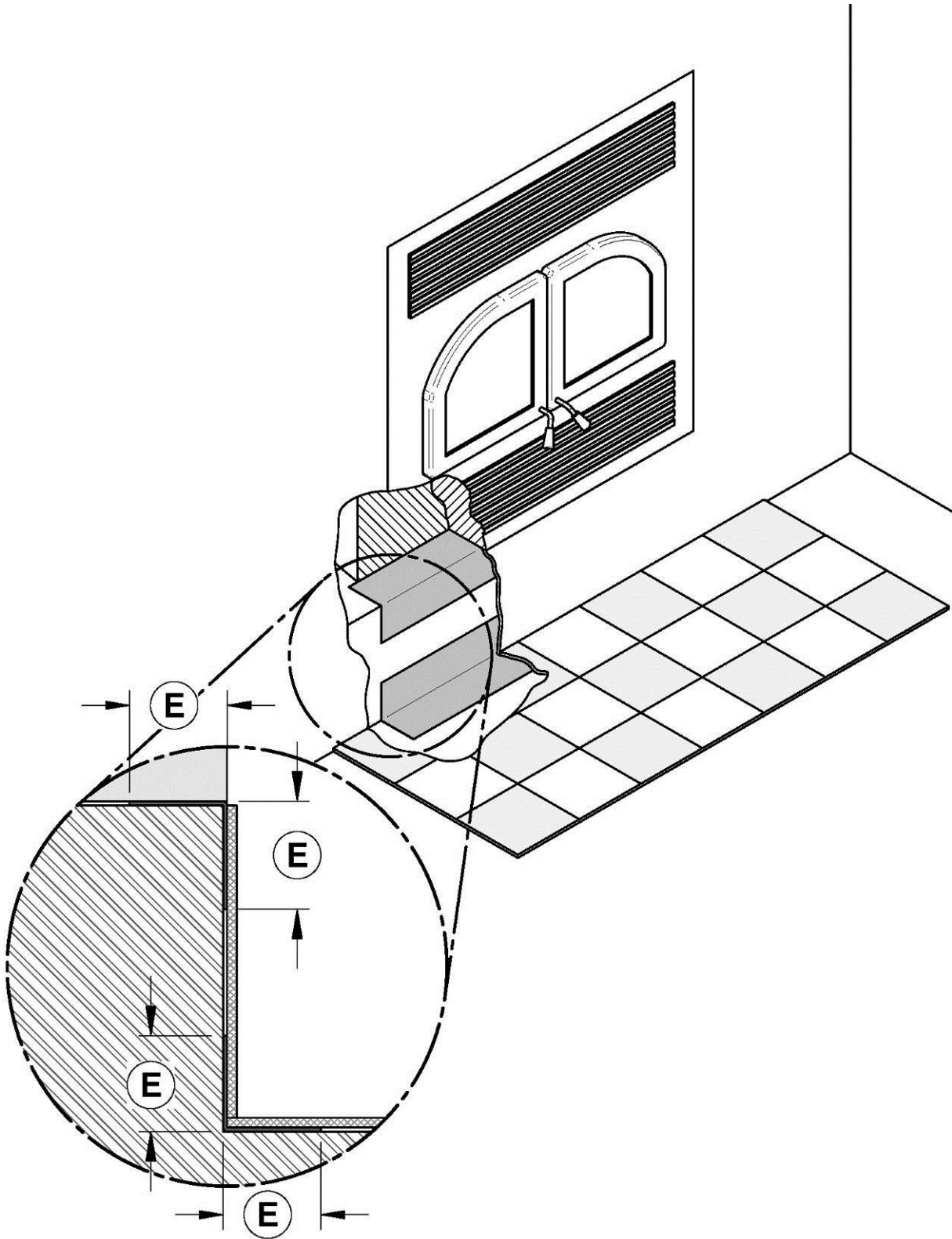

In the case where (F) would be equal to 4", it is suggested that the sheet metal between the base of the fireplace and floor be in one piece.

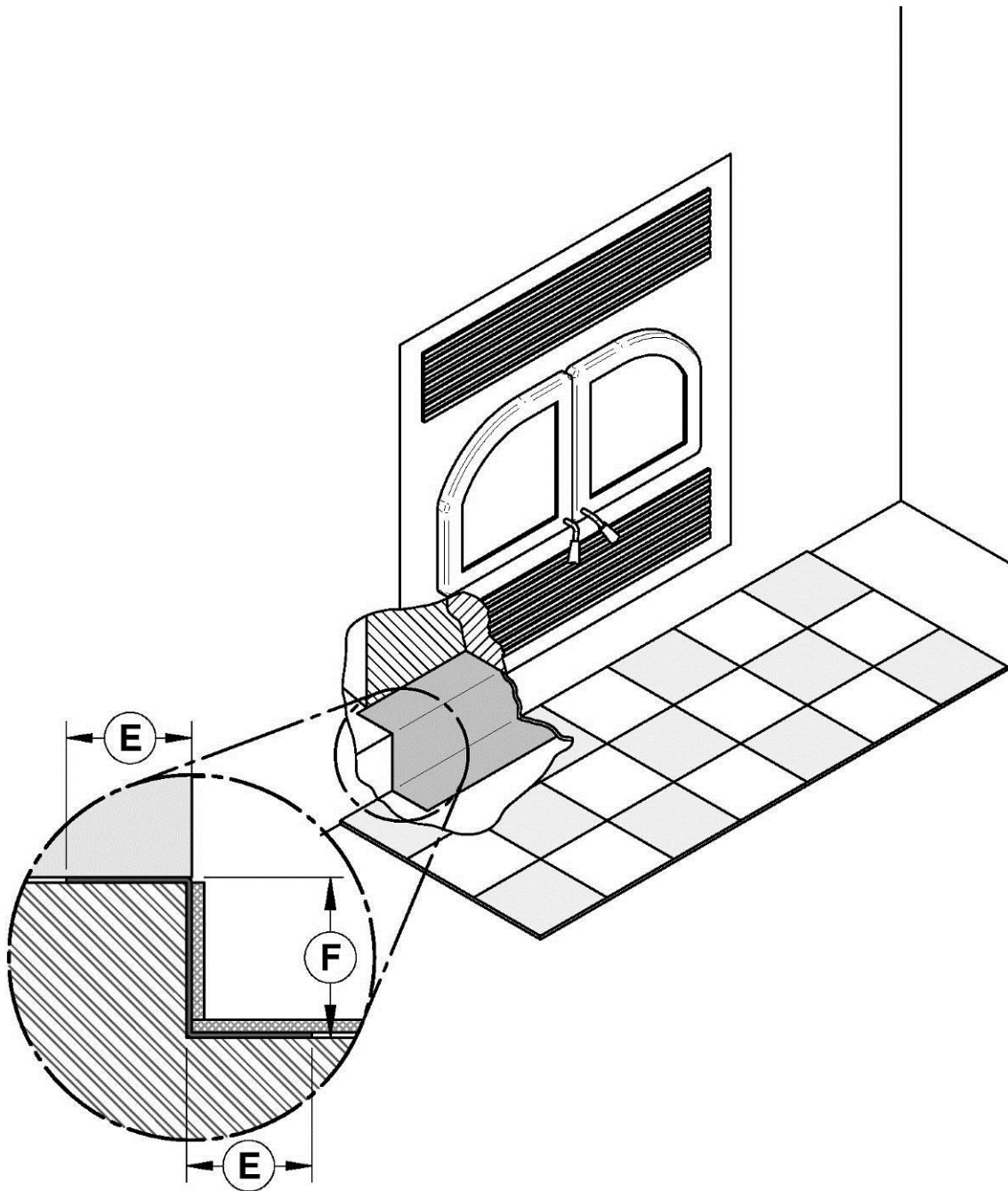

In the case where the fireplace is installed directly on the floor the joint between the hearth extension and the fireplace (E) must also be protected by a non-combustible material. For example, a sheet metal (not included).

Note that the floor under of the fireplace should match or exceed the height of the floor protection.

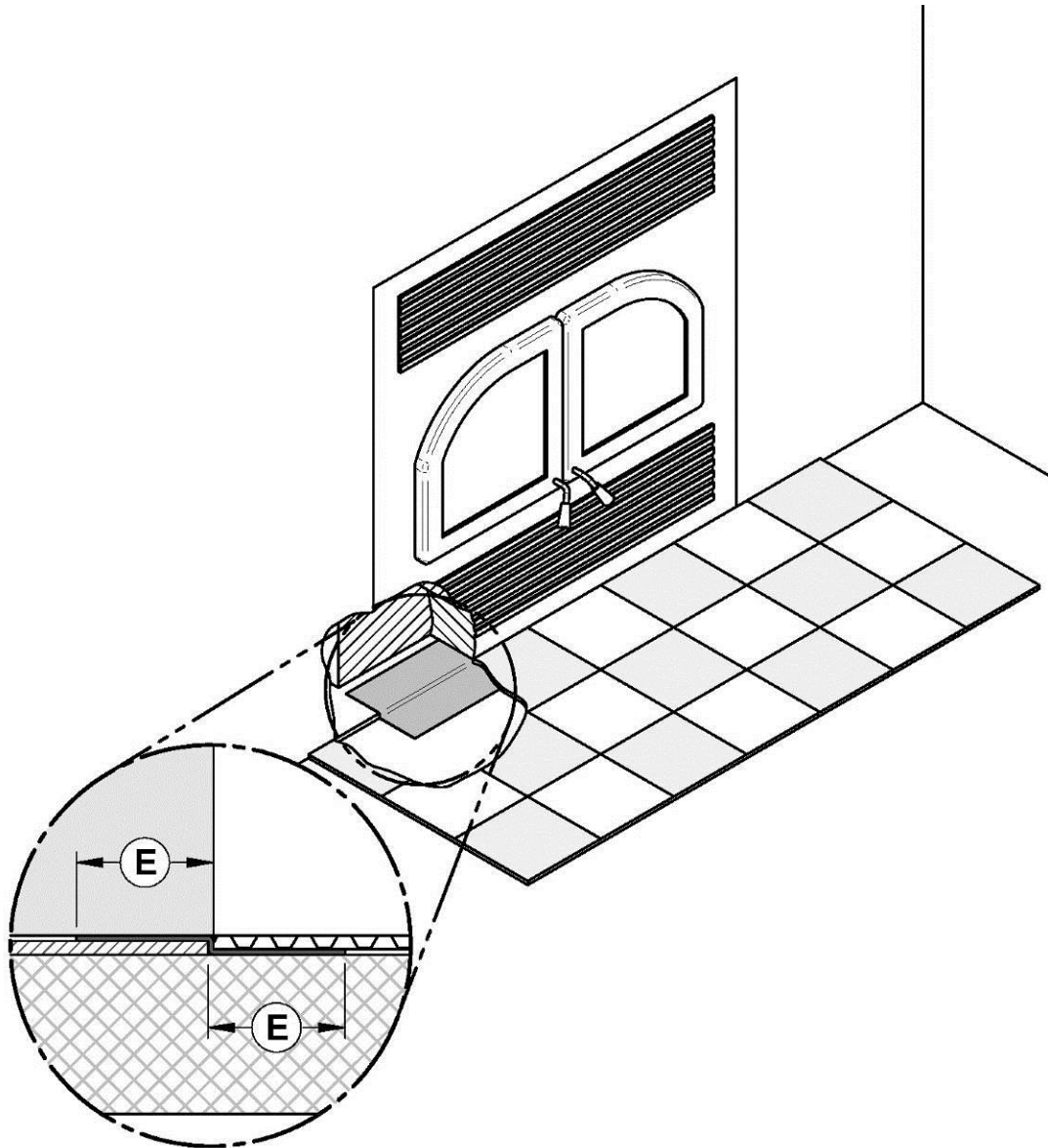

MINIMUM MEASUREMENT	
E	2" (51 mm)

A noncombustible floor protection must be installed in front of the unit. For more details see **Section 3.5: Minimum Hearth Extension Requirements**. The use of an R value is convenient when more than one material is going to be used in the hearth extension to cover the combustible surface. This is because R values are additive, whereas K values are not. To find the corresponding R factor to use for some selected materials, please see **Thermal Characteristics of Common Floor Protection Materials** table.

CAUTION: DO NOT LEAVE CARPET UNDER THE FLOOR PROTECTION IN FRONT OF THE FIREPLACE.

3.4 R-Value Calculations

There are two ways to calculate the R factor of the floor protection. First, by adding the R-values of the proposed materials or if some K and thickness values are given, by converting them to R values.

To calculate the R factor for a composite floor protection made of a combination of alternative materials, simply add the R-values of those materials. If the result is equal to or larger than the required R value, the combination is acceptable. For R-values of some selected materials, see Table **Thermal Characteristics of Common Floor Protection Materials**.

Example:

Required floor protection R of 1.00. Proposed materials: four inches of brick and one inch of Durock® board:

$$\text{Four inches of brick} \\ (R = 4 \times 0,2 = 0,8) \text{ plus 1 inch of Durock}^{\circledR} (R = 1 \times 0.52 = 0.52).$$

$$0.8 + 0.52 = 1.32.$$

This R value is larger than the required 1.00 and is therefore **acceptable**.

In the case of a known K and thickness of alternative materials to be used in combination, convert all K values to R by dividing the thickness of each material by its K value. Add the R values of your proposed materials as shown in the previous example.

Example:

$$K \text{ value} = 0.75$$

$$\text{Thickness} = 1$$

$$R \text{ value} = \text{Thickness}/K = 1/0.75 = 1.33$$

Thermal Characteristics of Common Floor Protection Materials*

MATERIAL	CONDUCTIVITY (k) PER INCH	RESISTANCE (R) PER INCH THICKNESS
Micore® 160	0.39	2.54
Micore® 300	0.49	2.06
Durock®	1.92	0.52
Hardibacker®	1.95	0.51
Hardibacker® 500	2.3	0.44
Wonderboard®	3.23	0.31
Cement mortar	5.00	0.2
Common brick	5.00	0.2
Face brick	9.00	0.11
Marble	14.3 – 20.00	0.07 – 0.05
Ceramic tile	12.5	0.008
Concrete	1.050	0.950
Mineral wool insulation	0.320	3.120
Limestone	6.5	0.153
Ceramic board (Fibremax)	0.450	2.2
Horizontal still air** (1/8")	0.135	0,920**

* Information as reported by manufacturers and other resources.

** For a 1/8" thickness. You cannot «stack» horizontal still air to accumulate R-values; you must separate each layer of horizontal still air with another non-combustible material.

3.5 Minimum Hearth Extension Requirements

The hearth extension floor area must extend at least 16" (41 cm) in front of the hearth (**A**) and at least 8" (20 cm) on each side of the door opening (**D**). The joint between the hearth extension and the fireplace hearth needs to be made of non-combustible material such as sheet metal (not included).

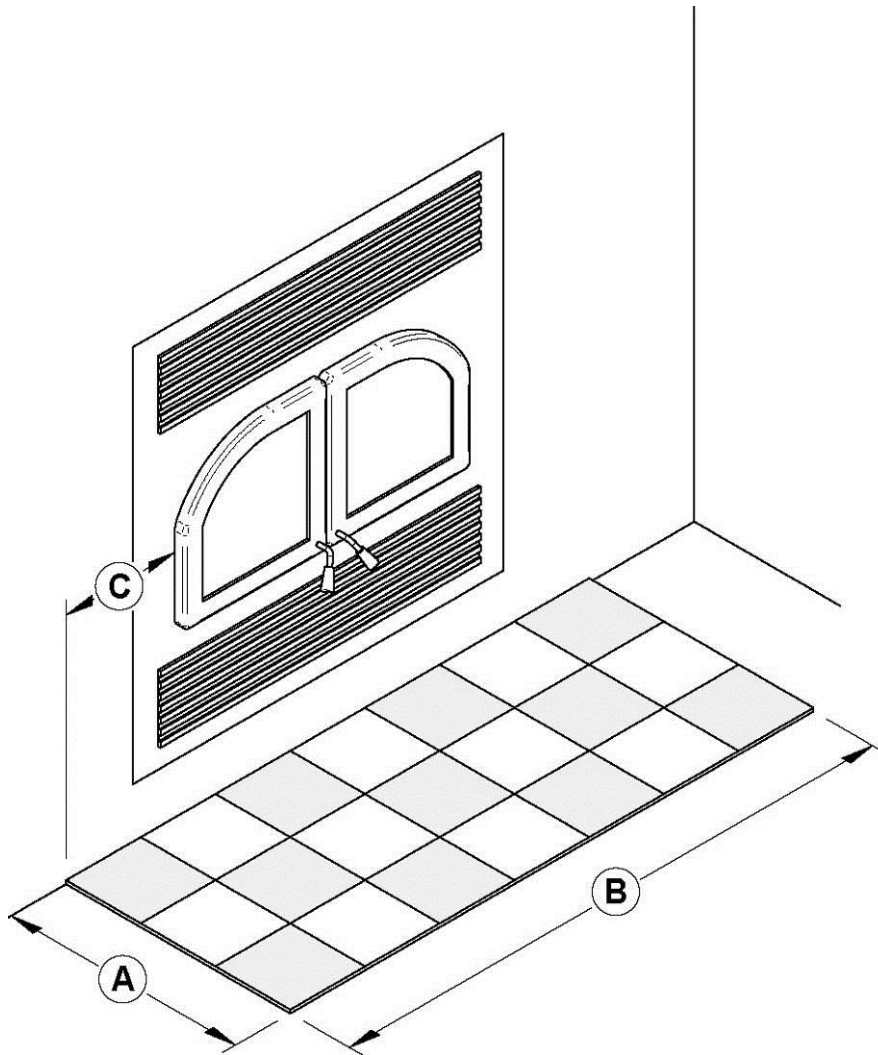

	CLEARANCES
A	16" (406 mm)
B	46" (1168 mm)
C	8" (203 mm)

3.6 Framing, Facing, Mantel, and Combustible Shelf

3.6.1 Framing

The construction of the framing, facing, and mantel must be in accordance with the standards and the following illustrations:

- A. Frame the fireplace using 2" × 3" (5 cm x 8 cm) or heavier lumber.

WARNING: COMBUSTIBLE FRAMING MATERIAL CANNOT BE USED IN THE SPACE DIRECTLY ABOVE THE FIREPLACE, EXCEPT FOR THE STUDS ABOVE THE FACING THAT SUPPORT THE FACING MATERIAL AND MANTEL. THIS AREA MUST REMAIN EMPTY FOR A HEIGHT OF 6' (1.83 M) MEASURED FROM THE BASE OF THE APPLIANCE.

- B. Frame the fireplace with vertical studs on each side of the fireplace running from floor to ceiling. Position the studs back from the front edge of the fireplace, leaving a space the thickness of the facing material so that the facing can be installed flush with the fireplace facing within limitations of figures and tables bellow. Frame headers between the vertical studs only as follows:
- Place 2" x 3" (5 cm x 8 cm) or 2" x 4" (5 cm x 10 cm headers, only along the upper part of the front, side and back faces. Do not put wood or any combustible material within the area above the fireplace except on the front facing.
 - Place headers only as required to support the facing and mantel.

WARNING: DO NOT PACK REQUIRED AIR SPACES WITH INSULATION OR OTHER MATERIAL.

WARNING: THE FIREPLACE MUST NOT BE IN CONTACT WITH ANY INSULATION OR LOOSE FILLING MATERIAL. COVER THE INSULATION WITH DRYWALL PANELS AROUND THE FIREPLACE.

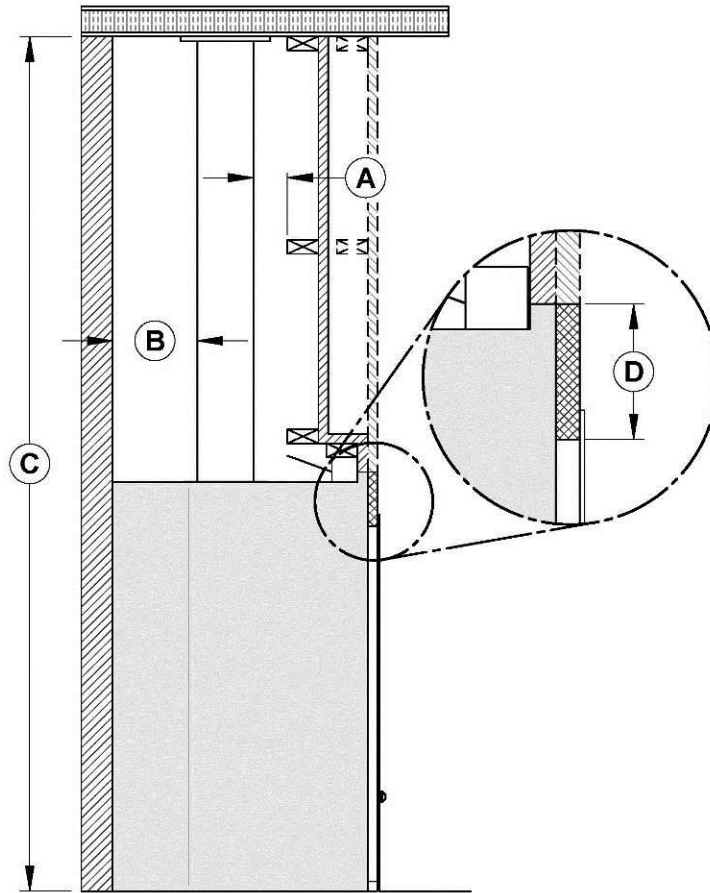

Wall finish behind the fireplace's faceplate installation

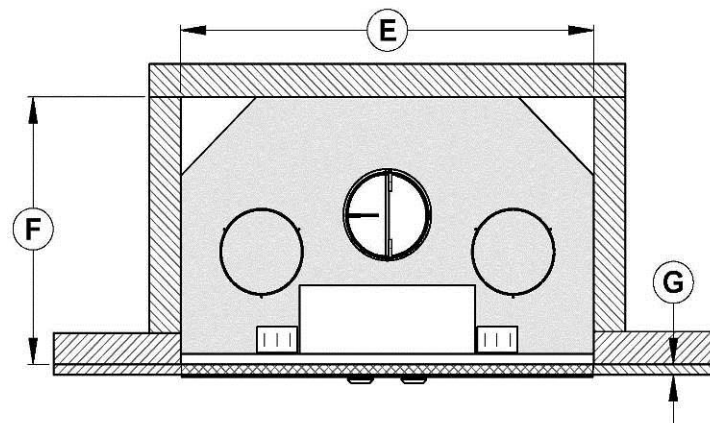

	CLEARANCES
A	2" (51 mm)
B*	6 7/8" (175 mm)
C*	72" (1829 mm) minimum
D*	5 1/2" (140 mm)



	MEASUREMENTS
E*	41 1/8" (1045 mm)
F*	25 1/2" (648 mm)
G	1 3/8" (35 mm) MAX

*When drywall panels or any other finishing material inside the chase around the fireplace is to be used, add its thickness to the measurement.

See **Section 3.9: Fresh Air Intake Kit** to install this kit (K) and **Appendix 1: Optional Heat Management Systems Installation (AC01375, AC01376 or AC01340)** to see the different heat management systems (L) installation.

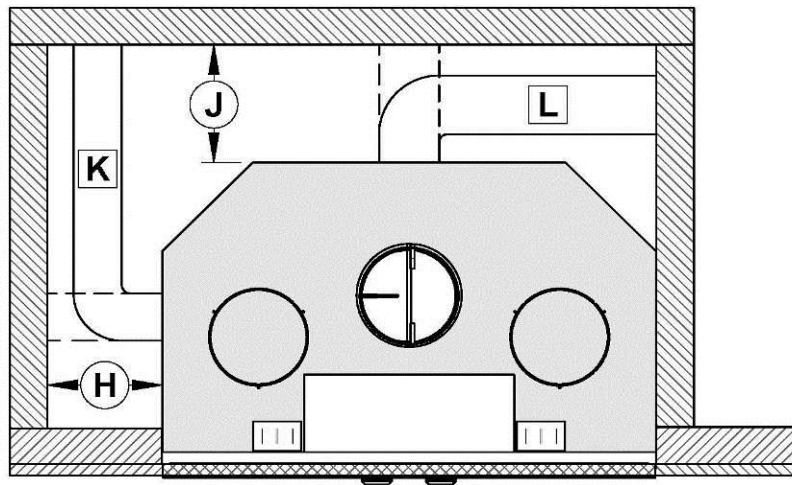
Fresh air intake kit or forced air distribution kit installation

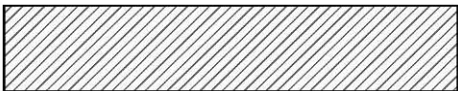

LEGEND	
	Combustible material allowed in this area
	Non-combustible material only in this area

	MINIMUM MEASUREMENTS FOR FRESH AIR INTAKE KIT (K)**	MINIMUM MEASUREMENTS FOR FORCED AIR DISTRIBUTION KIT (L)**
H*	12" (305 mm)	18" (457 mm)
J*	12" (305 mm)	18" (457 mm)

*When drywall panels or any other finishing material inside the chase around the fireplace is to be used, add its thickness to the measurement.

** The fresh air intake kit may be installed on the left side only and the forced air distribution kit may be installed either on the sides or on the back.

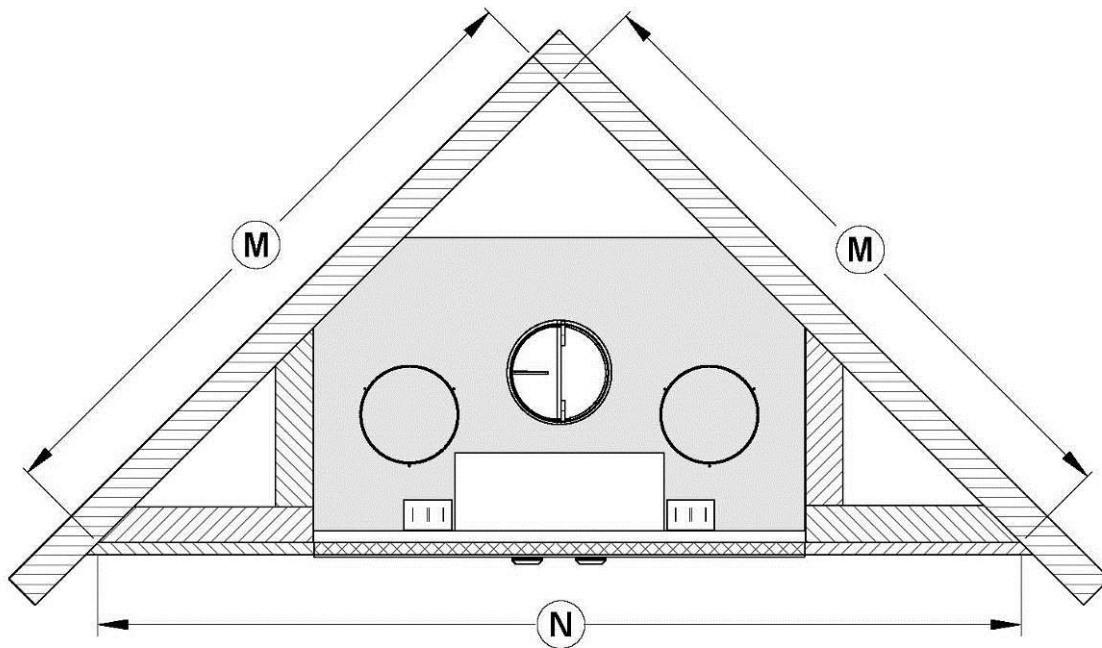

CLEARANCES**	
M*	54 9/16" (1386 mm)
N*	77 3/16" (1961 mm)

*When drywall panels or any other finishing material inside the chase around the fireplace is to be used, add its thickness to the measurement.

**Values M and N are minimum measurements. They may need to be increased to allow installation of a Fresh air intake kit or forced air distribution kit, or depending on the finish material used.

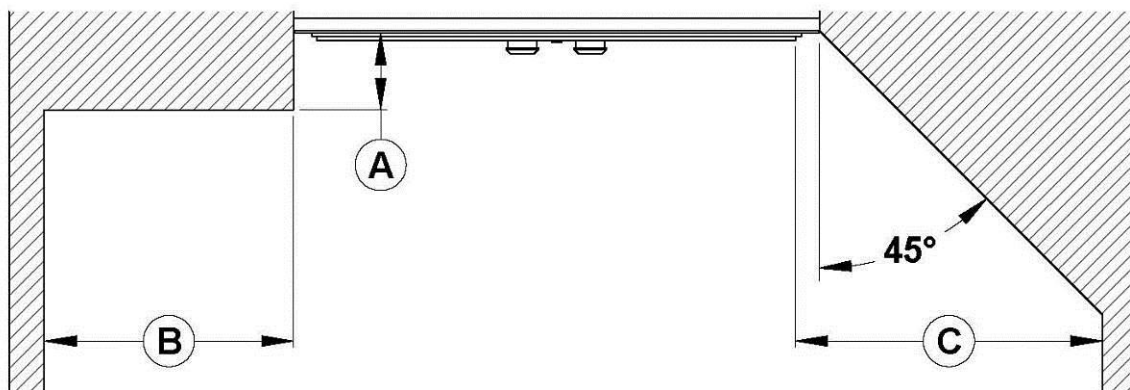

CLEARANCES	
A	6" (152 mm) maximum
B	18 1/2" (495 mm) minimum
C	24" (610 mm) minimum



*Measurements for (C) clearances are taken from door opening.

3.7 Facing

1. Materials directly in contact with the faceplate of the fireplace, especially the vertical and horizontal surround, must be non-combustible and have the minimal dimensions as shown bellow.
2. Non-combustible materials such as brick, stone or ceramic tile may project in front of and onto the fireplace decorative frame.

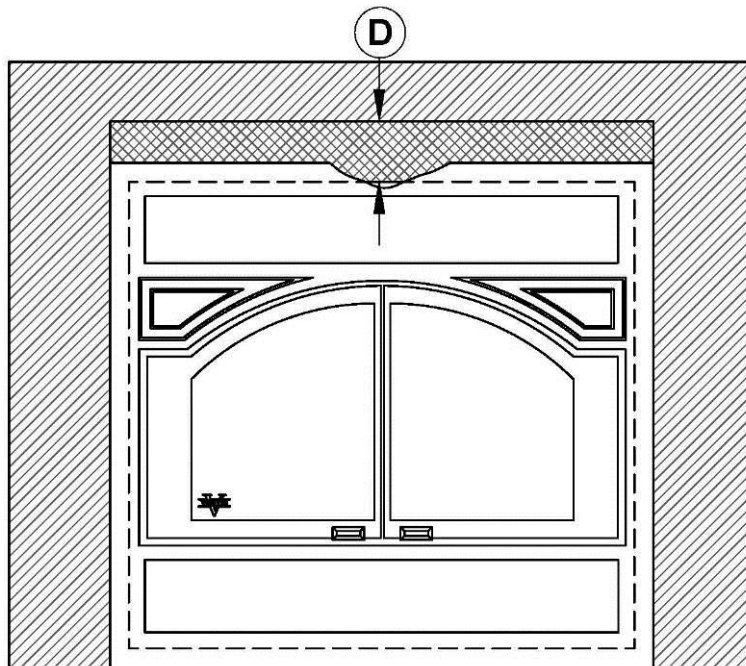
CAUTION: MATERIALS MUST BE INSTALLED SO THAT THE FACEPLATE MAY BE REMOVED AFTER THE INSTALLATION. THE FACEPLATE IS DESIGNED TO OVERLAP THE MATERIAL SURROUNDING THE FIREPLACE. IF THE MATERIAL IS THICKER, USE A FACEPLATE GAUGE FOR POSITIONING AND MAKE SURE THAT THE FACEPLATE CAN BE REMOVED AFTER IT HAS BEEN INSTALLED (PLEASE DISMISS IF YOU INSTALL THE MASONRY FACEPLATE OPTION).

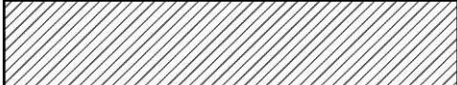

LEGEND	
	Combustible material allowed in this area
	Non-combustible material only in this area

D	5 1/2" (140 mm)
----------	-----------------

3.8 Compliance of a Combustible Mantel Shelf

To ensure compliance of an existing mantel shelf or to install a combustible mantel shelf, refer to table and figure in this section. For example, a mantel shelf with a 6" depth (152 mm) ((C) value) must be installed at least 48" (1219 mm) ((B) value) above the bottom of the fireplace (see figure and tables in this section). Different mantel shelf dimensions are listed in the following table. However, no combustible mantel shelf can be installed at less than 48" (1219 mm) above the bottom of the fireplace. If the depth of the mantel shelf is not listed in the table below, add 42" (1067 mm) to the depth of your mantel shelf to obtain the safe positioning of your mantel shelf. For example, for a 9" (229 mm) mantel shelf, the safe positioning would be 51" (1295 mm) above the bottom of the fireplace 42" (1067 mm) + 9" (229 mm)).

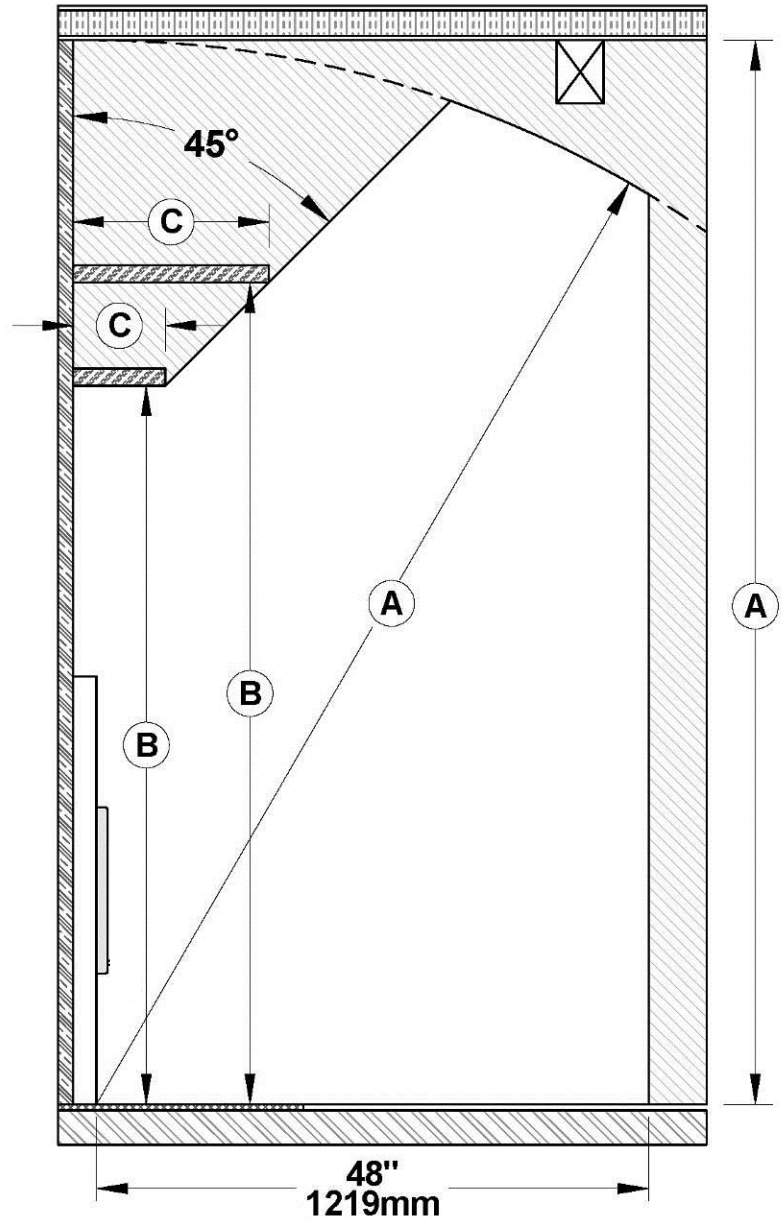

CLEARANCES	
A	72" (1829 mm)

SHELF POSITIONING	
B	C
48" (1219 mm)	6" (152 mm)
50" (1270 mm)	8" (203 mm)
52" (1321 mm)	10" (254 mm)
54" (1372 mm)	12" (305 mm)

3.9 Fresh Air Intake Kit

During operation, the fireplace requires fresh air for combustion and draws air out of the house. It may starve other fuel burning appliances such as gas or oil furnaces. As well, exhaust fans may compete for air, causing negative pressure in the house, resulting in smoke entering the house from the fireplace. This situation is aggravated in modern airtight houses. To overcome this problem, we strongly recommend that you bring fresh air to the fireplace. **Check with local authorities having jurisdiction in your area, it may be mandatory.**

THE INSULATED FLEXIBLE PIPE LENGTH SHOULD BE SUFFICIENT AND HAVE A CONFIGURATION TO AVOID CONDENSATION.

THE OUTSIDE WALL TERMINATION MUST NOT BE INSTALLED AT MORE THAN 50% OF THE TOTAL HEIGHT OF THE CHIMNEY AND AT THE MOST 10 FT. (3 M) ABOVE THE BASE OF THE FIREPLACE.

THE FRESH AIR MUST COME FROM OUTSIDE THE HOUSE. THE AIR INTAKE MUST NOT DRAW AIR FROM THE ATTIC, FROM THE BASEMENT, OR FROM A GARAGE.

THE OUTSIDE WALL TERMINATION SHOULD BE INSTALLED WHERE IT IS NOT LIKELY TO BE BLOCKED BY SNOW OR EXPOSED TO EXTREME WIND AND AWAY FROM AUTOMOBILE EXHAUST FUMES, GAS METER AND OTHER VENTS.

Your fresh air kit contains the following components:

- a. One (1) 4" adapter (D);
- b. Two (2) screws (E);

The following components are not included:

- a. A 4" insulated flexible pipe (This HVAC type pipe must comply to ULC S110 and/or UL 181, Class 0 or Class 1 Standards and must withstand temperatures up to 250 °F.
- b. The outside air inlet cap
- c. The 2 adjustable clamping ring

To complete the fresh air installation, you will need a 4" insulated flexible pipe. Use the length required for your installation while respecting the maximum length of 30 ft (9 m). To avoid condensation, it is recommended to use an insulated pipe long enough and containing a "P-Trap" loop. This configuration can be found inside the chase, but must at all times maintain clearances to combustibles.

Remove the knock out (A) located on the left-hand side of your fireplace. Then cut and remove the insulation (B) and remove the inner knock-out (C). Install 4" adapter (D) included in your fireplace with the 2 screws (E).

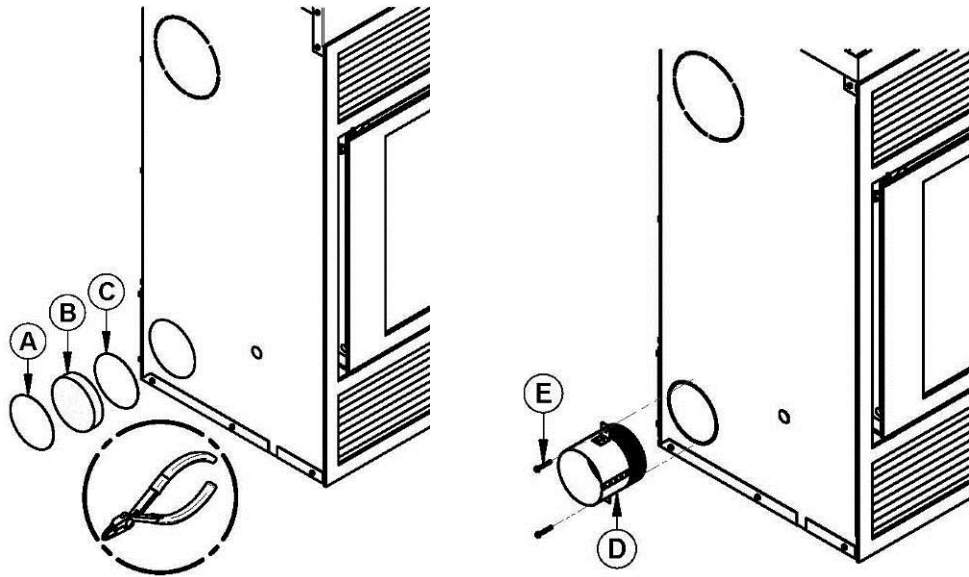

To complete the installation, make a hole of 1/4" to 1/2" (6 mm à 13 mm) bigger than the insulate pipe diameter in the outside wall of the house at the chosen location. From outside, place the outside air inlet cap in the hole (open side down) and fasten the register to the wall, with screws as shown bellow. Place the insulated pipe over the register tube and over the fireplace outside air connector. At each end, carefully pull back the insulation and plastic cover, exposing the flexible pipe. Attach the flexible pipe using pipe clamps. For a better seal, you may also use aluminum tape. Wrap the tape around the joint between the flexible pipe and the air inlets. Carefully push the insulation and plastic cover back over the pipe. Fix the plastic in place using aluminum tape.

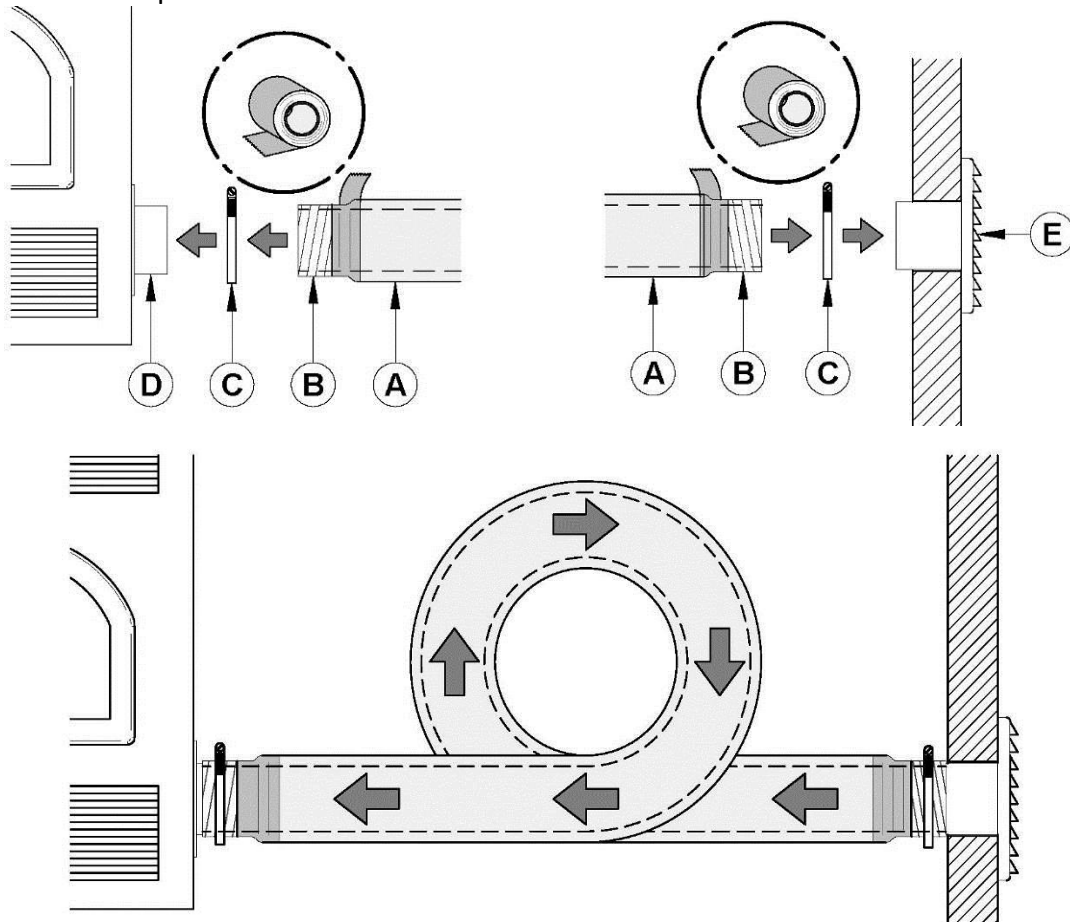

3.10 Installation of a Gas Lighter

We have tested this fireplace with a gas lighter. The input of the gas lighter did not exceed 27,000 BTU/h. Therefore, when this maximum input is not exceeded, the temperatures reached by the fireplace are within its safety requirements. Please note that other building code requirements may apply. Such requirements may relate to the safety of the gas lighter itself, its connection, its performance, and/or its operation. As a result, our responsibility is strictly limited to the safety of the fireplace with regards to temperatures that can be reached by the appliance when it is equipped with a certified gas lighter meeting the maximum input described above. A gas lighter has not been tested with glass doors closed. Therefore, when a gas lighter is burning, close the fireplace screens and keep the glass doors open.

3.11 Faceplate Installation VBA1520 (Sold Separately)

In order to perform installation of VBA1520 faceplate, refer to Installation manual included in the faceplate kit.

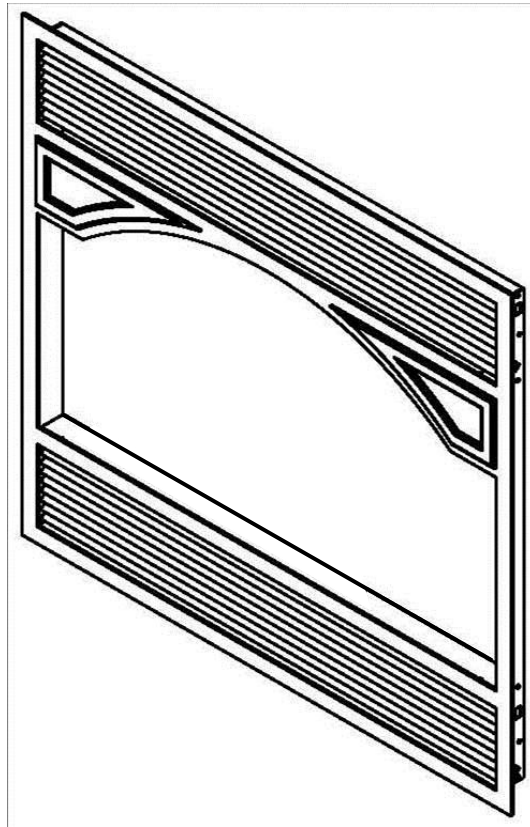

VBA1520
TRADITIONAL STYLE FACEPLATE - METALLIC BLACK

3.12 The Use of the Fire Screen

To take advantage of mesh doors, the glass doors can be removed from their hinges. Note that the mesh door may be removed for cleaning purposes, but must always be in place and closed when the fireplace is in use, even if the glass doors are closed.

OPERATE ONLY WITH GLASS DOORS FULLY CLOSED OR FULLY OPEN WITH MECHE DOORS ALWAYS CLOSED. IF DOORS ARE LEFT PARTLY OPEN, GAS AND FLAME MAY BE DRAWN OUT OF THE OPENING, CREATING RISKS FROM BOTH FIRE AND SMOKE. NEVER LEAVE THE FIREPLACE UNATTENDED WHEN IN USE.

THIS FIREPLACE HAS BEEN TESTED FOR USE WITH OPEN DOORS IN CONJUNCTION WITH MECHE DOORS ALWAYS CLOSED. THE MECHE DOORS MAY BE OPENED ONLY DURING LIGHTING PROCEDURES OR RELOADING. ALWAYS CLOSE THE MECHE DOORS AFTER IGNITION.

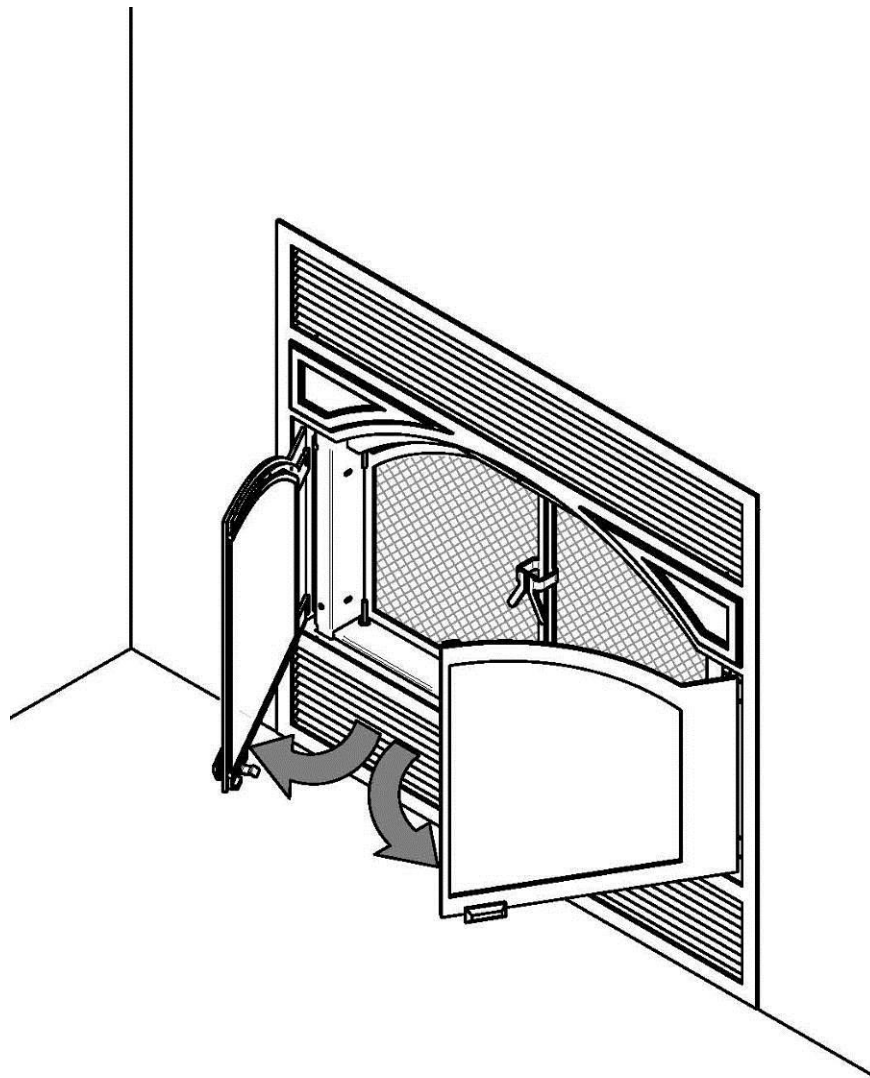

4 VENTING SYSTEM

4.1 General Information

The venting system is the engine that drives your wood heating system. Even the best fireplace will not function safely and efficiently as intended if not connected to a suitable chimney. The heat in the flue gases that pass from the fireplace to the chimney is not wasted heat. This heat is what the chimney uses to make the draft that draws in combustion air and keeps the combustion gases within the fireplace. You can think of heat in the flue gas as the fuel the chimney uses to make draft.

4.2 Suitable Chimney

This wood fireplace may be connected to a factory-built metal chimney. To be suitable, a factory-built metal chimney must comply with UL 103HT (U.S.A.), ULC S629 (Canada), ULC S-604 (Canada) or UL S-610 (U.S.A). Factory-built chimneys are tested as a system with all the necessary components for installation. The instructions provided with the chimney by the manufacturer approved for this fireplace are the only reliable source of installation guidelines. To be safe and effective, the chimney must be installed exactly in accordance with the manufacturer's instructions. **Use only components intended for the brand and model of chimney you are using. Never substitute parts from other chimney brands or build your own components.**

This wood fireplace is to be connected to a Ventis chimney with an 8" diameter flue passage.

TABLE 1 - LISTED CHIMNEY FOR YOUR ME300 WOOD FIREPLACE

CHIMNEY MANUFACTURER	BRAND	TYPE	INNER DIAMETER
Olympia Chimney	Ventis	1" Solid Pack	8" (20 cm)

WARNING: THE CHIMNEY MUST START WITH AN 8" DIAMETER ANCHOR PLATE SECURED TO THE FIREPLACE.

WARNING: IF THE MALE NOZZLE (A) OF THE ANCHOR PLATE EXCEEDS 2" (51 MM) IN LENGTH (SEE IMAGE BELOW), IT SHALL BE CUT ABOVE THE LIFTING HOOKS WELDED TO THE INSIDE OF THE FLUE OUTLET SO THAT THE ANCHOR PLATE RESTS PERFECTLY ON TOP OF THE FIREPLACE.

CAUTION: IF THE FLUE OUTLET IS CUT ONLY AROUND THE HOOKS, MAKE SURE THAT THE FLUE DAMPER MECHANISM WORKS PROPERLY BEFORE CLOSING THE WALLS.

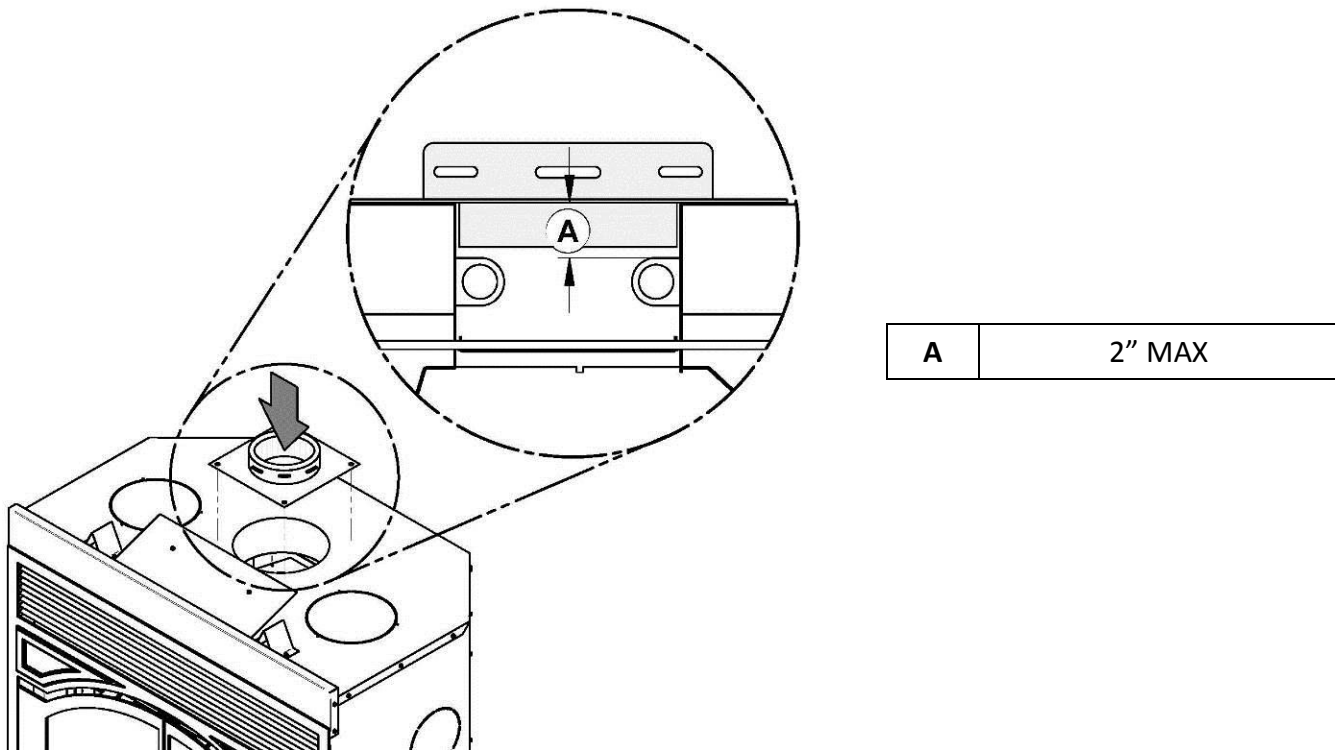

4.3 Chimney Installation Notes

1. If possible, install an interior chimney as it will provide better performance. In areas with continuous temperatures below -18°C (0°F), the use of an exterior chimney increases the likelihood of operating problems such as low draft, high rate of creosoting, and poor start-up characteristics. Exterior chimneys are also prone to down-drafting and flow reversal. Installations, which are located on lower floors in the house, such as in a basement, in combination with outside chimney, are especially prone to flow reversal.
2. The ME300 is listed only with chimney systems described in table 1.
3. A chimney venting a fireplace shall not vent any other appliance.
4. The minimum chimney system height for a straight installation is 15 ft. (4.5 m).
5. Chimney installation must include at least one support. Reducing the amount of chimney weight on the fireplace will help avoid the noise created when the fireplace expands. This can be achieved by having the chimney supported by the supports. The maximum chimney length that should be supported by the fireplace is 12 ft. (3.7 m) for 1" Solid Pack Chimney.
6. The chimney must extend at least 3 ft. (92 cm) above its point of contact with the roof and at least 2 ft. (61 cm) higher than any wall, roof or building within 10 ft. (3.1 m) of it. See figures below to determine the configuration that applies to your roof (flat or sloped roof and the distance between the chimney and the highest point of the roof and/or the nearest chimney).

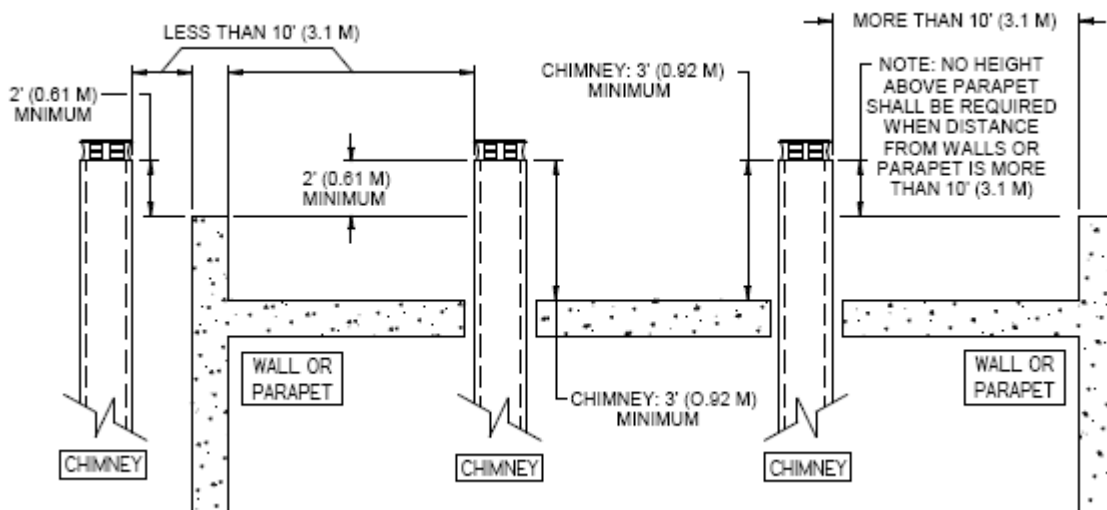
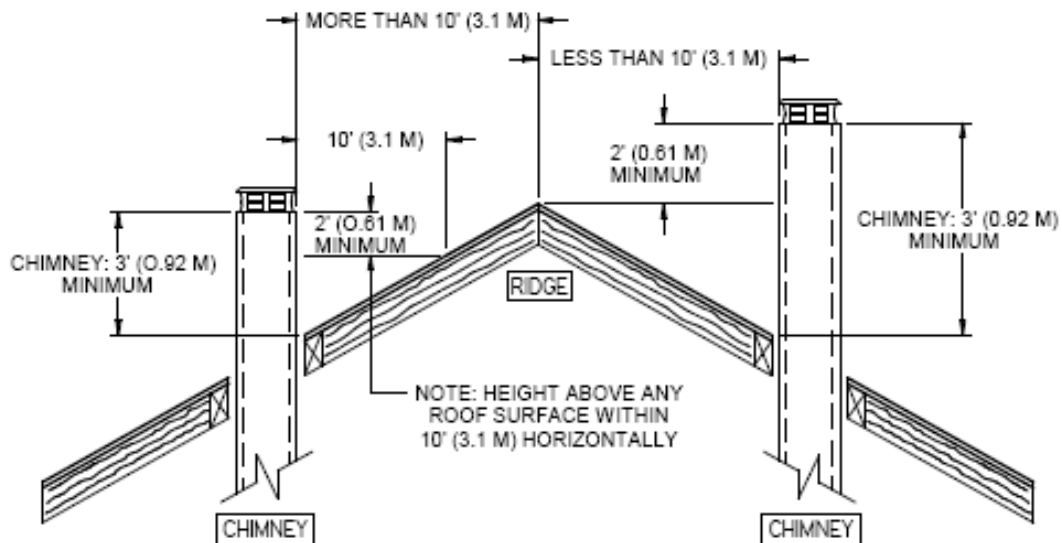

7. Deviations should be avoided whenever possible, especially the most pronounced. Each deviation adds some restriction to the chimney system and may lead to draft problems.
8. If the chimney extends higher than 5 ft. (1.5 m) above its point of contact with the roof, it must be secured using a roof brace.
9. A rain cap must be installed on top of the chimney. Failure to install a rain cap may cause corrosion problems.
10. Cut and frame square holes in all floors, ceilings, and roof that the chimney will go through to provide a 2" (50 mm) minimum clearance between the chimney and any combustible materials. Do not fill this 2" space with insulation or any other combustible material.
11. Portions of the chimney which may extend through accessible spaces must be enclosed to avoid contact with combustible materials or damage the chimney.

12. For installations where more than one chimney is located in the same non-chase or within the same area, we suggest that their terminations be separated by at least 16" (410 mm) horizontally, and 18" (460 mm) vertically. This separation is to prevent smoke migrating from one chimney to another.

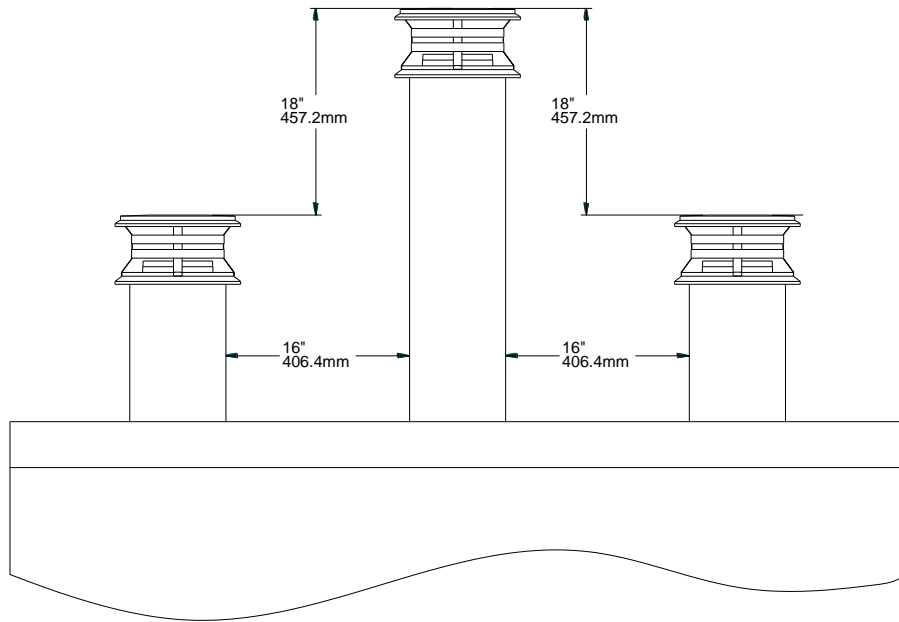

4.4 Chimney Installation Instructions

Always refer to the chimney manufacturer's Installation manual to ensure a safe installation. Some non-illustrated parts may be required.

4.4.1 Examples of Typical Chimney Installation

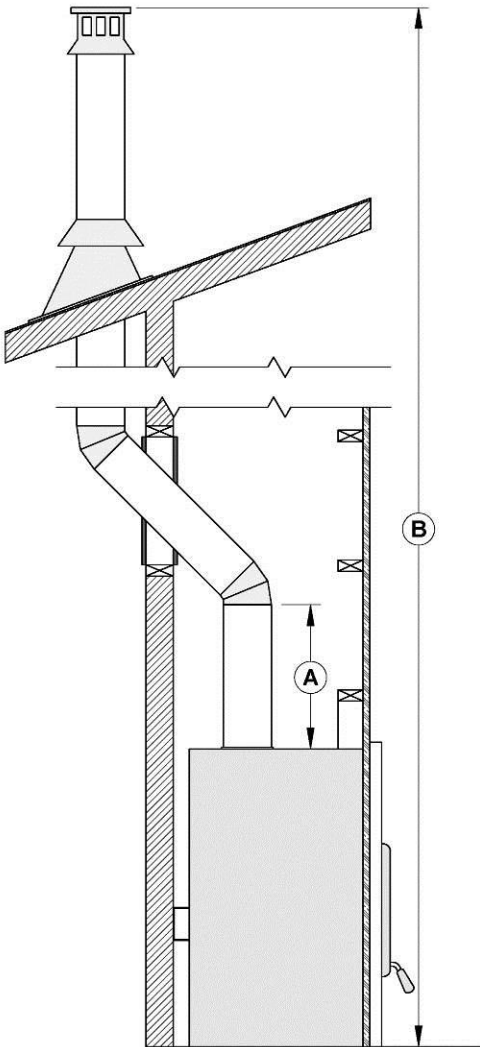

A	To insure a good draft, it is recommended to have a length of 18 inches from the top of the unit to the first offset. However, starting using a 30° or 45° elbow is also approved.
B	Mandatory measure of 15 ft. from the bottom of the fireplace to the top of the outside chimney.

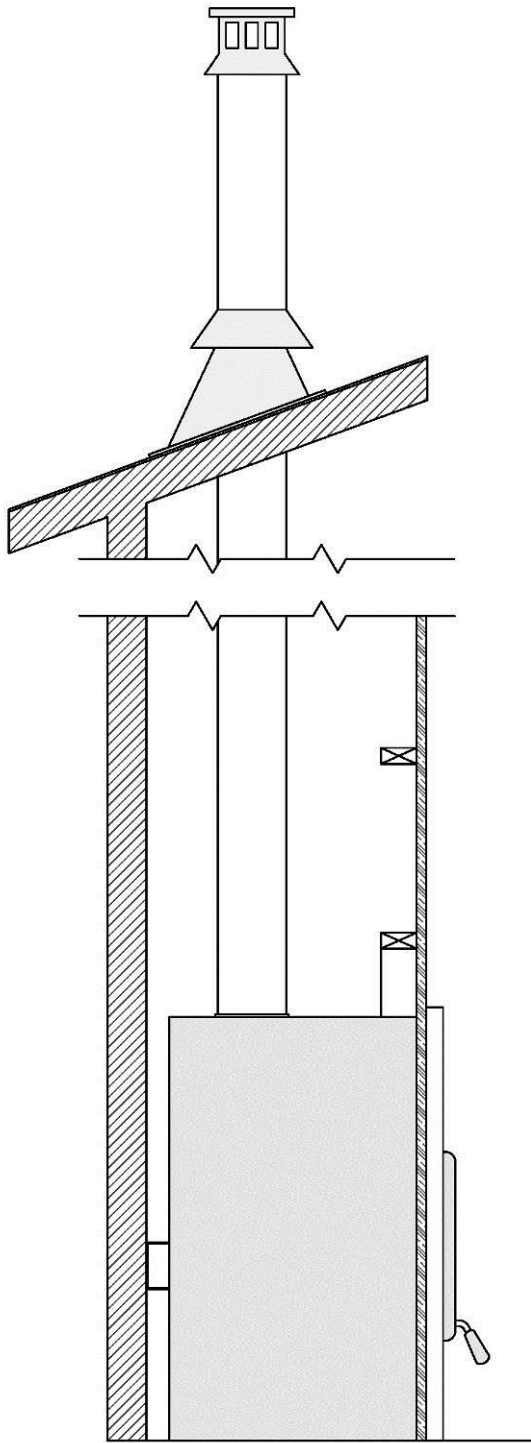

Direct installation

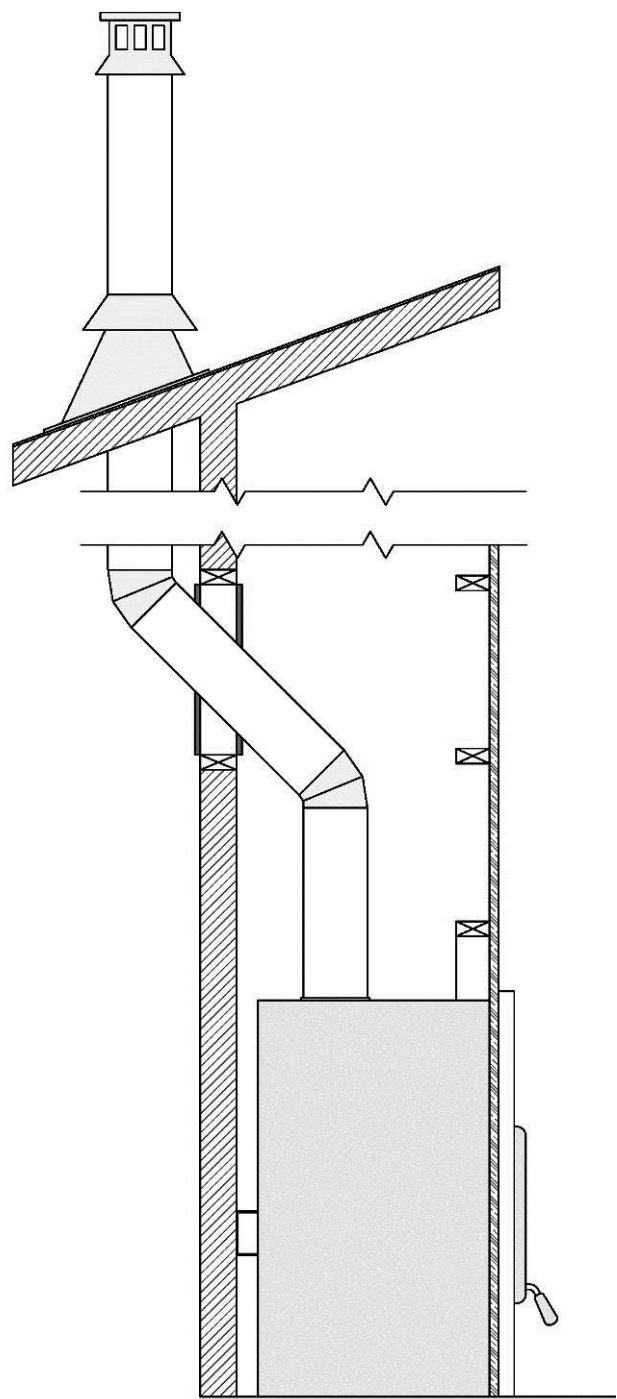

Exterior offset installation

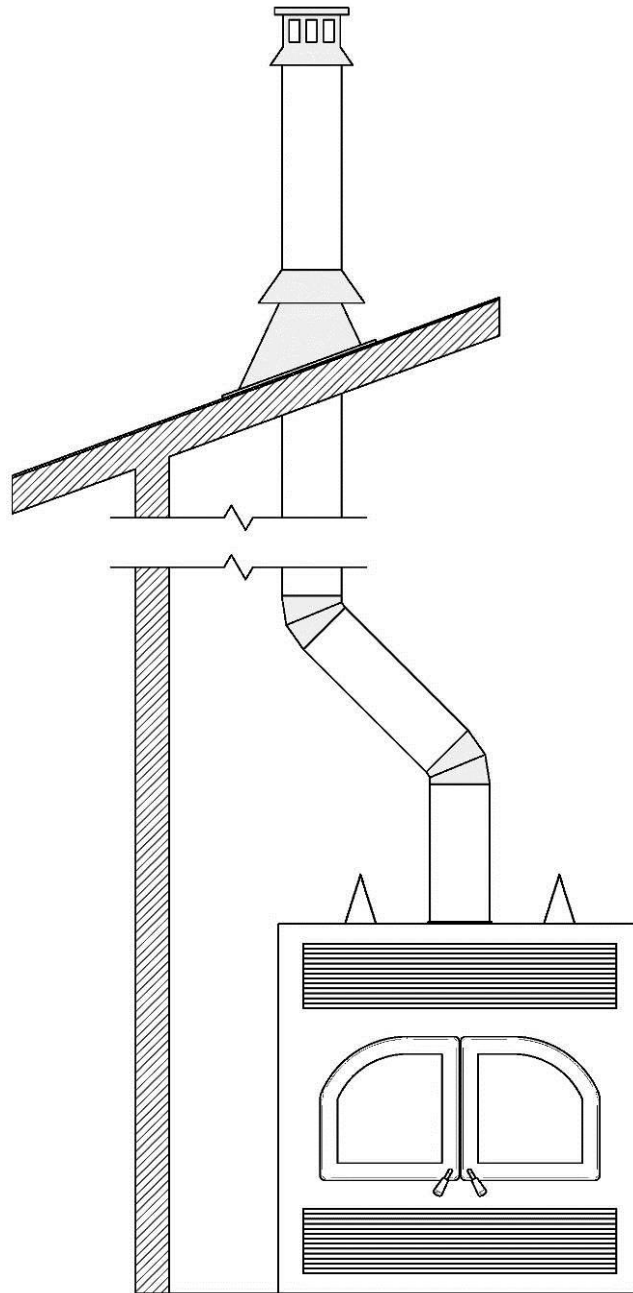

Interior offset installation

1. Cut and frame the holes in the ceiling, floor and roof where the chimney will pass. Use a plumb bob to line up the center of the holes. Make sure that the size of the floor and ceiling holes are in accordance with the chimney manufacturer's instructions.
2. From below, install a firestop (B) supplied by the chimney manufacturer in each ceiling/floor separation through which the chimney will pass. At the attic level, install a radiation shield from above (D).
3. Follow the chimney's manufacturers' instructions and place the first chimney length on the fireplace. You must use an anchor plate (A) supplied by the chimney manufacturer before installing the first chimney length. Continue installing chimney lengths making sure to lock each length in place.
4. Every time the chimney passes through a ceiling or a wall, install the appropriate firestop. When you reach the desired height, install the roof support (not illustrated). (Refer to instructions included with the support).

5. Then, put the roof flashing (E) in place and seal the joint between the roof and the flashing with roofing pitch. For sloping roofs, place the flashing under the upper shingles and on top of the lower shingles. Nail the flashing to the roof, using roofing nails.
6. Place the storm collar (F) over the flashing, and tighten it with the bolt supplied. Finally, seal the joint between the storm collar and the chimney, using silicone caulking.
7. Install the chimney cap (G).
8. When a ventilated roof flashing is installed, precautions are to be taken not to caulk or seal the ventilating openings.

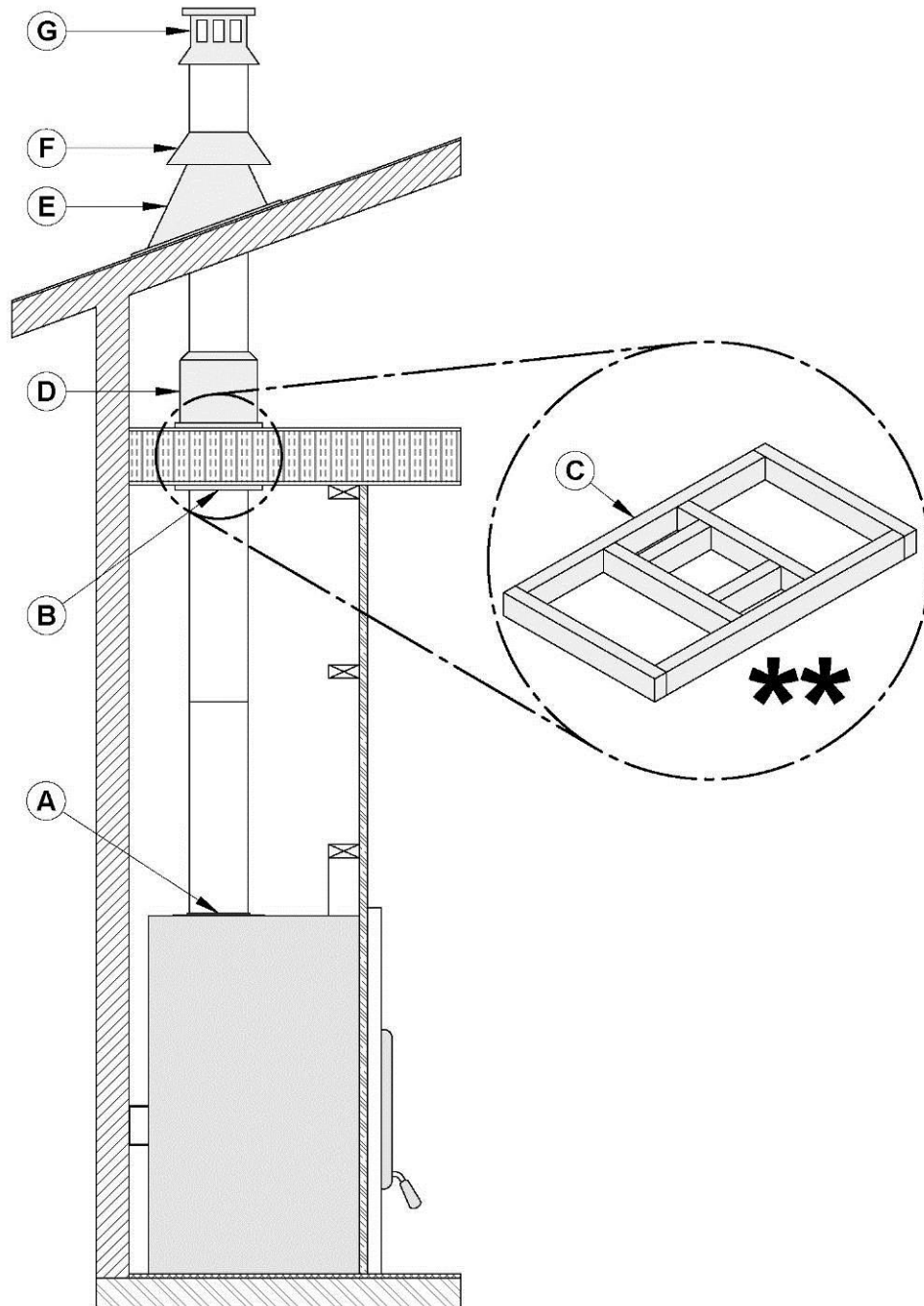

**** THE STRUCTURAL INTEGRITY OF THE FLOOR, WALL, AND CEILING/ROOF MUST BE MAINTAINED**
NOTE: THE FLOOR AND WALLS BELOW THE ATTIC MUST BE INSULATED USING THE SAME INSULATION.

4.5 Offset Chimney Installation

TABLE 2 – THE MINIMUM SYSTEM HEIGHT WHEN USING ELBOWS

Fireplace model	ME300 WOOD FIREPLACE
Chimney model	See Table 1
Vertical installation	15 ft. (4.5 m)
Two (2) elbows	15 ft. (4.5 m)
Four (4) elbows	17 ft. (5.2 m)

After reaching the location requiring the elbow, proceed as follows:

1. To insure a good draft, it is recommended, but non-mandatory, to have a length of 18 inches (457 mm) from the top of the unit to the first offset. Install the first elbow; turn it in the required direction. Secure it to the chimney according to the chimney manufacturer's instructions. In many cases, it is recommended to secure connections with three (3) ½" (12 mm) metal screws.
2. Install the necessary chimney lengths to achieve the required offset. Lock the chimney lengths together according to the chimney manufacturer's instructions. It is recommended to use three (3) ½" (12 mm) metal screws. If the offset length is made of two (2) chimney lengths or more, Olympia Chimney require that you use an offset or roof support halfway up the offset. If penetrating a wall, install a wall radiation shield supplied by the chimney manufacturer (see **Section 4.4.1: Examples of Typical Chimney Installation**).
3. Use another elbow to turn the chimney vertically. Secure the elbow.
4. Use a plumb bob to line up the centre of the hole. Cut a hole for the chimney in the ceiling/floor. Frame this hole as described previously.
5. From below, install a firestop supplied by the chimney manufacturer.
6. A support must be used on the first 15' section (4.6 m).
7. Continue with the regular installation.

4.5.1 Angled Wall Radiation Shield

When passing through a combustible wall with the chimney at a 30° or 45° angle (30° or 45° in Canada and 30° only in the USA), an angled firestop or wall radiation shield provided by the chimney manufacturer must be installed. Only one is required. Follow the chimney manufacturer's installation instructions.

In cold climate locations, it is recommended that you use the insulated wall radiation shield since it will maintain the home's thermal barrier.

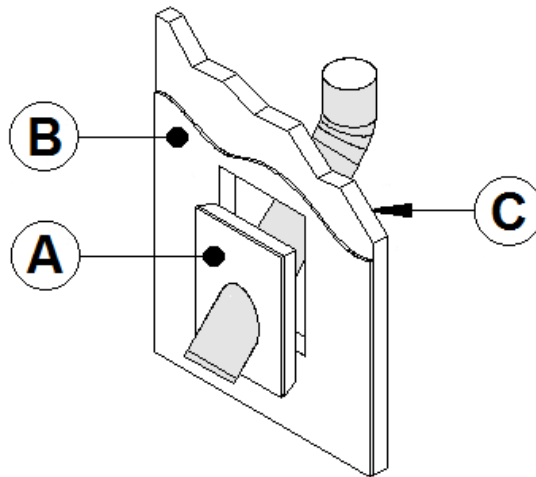

A	INSULATED WALL RADIATION SHIELD
B	GYPSUM BOARD
C	INSULATED WALL

4.6 Chimney Support Installation

4.6.1 Universal Roof Support

This support has three possible uses:

1. It must be used on a roof to support the chimney.
2. It may be used on a floor, ceiling or roof above an offset to support the chimney above the offset.
3. It may be used on a floor, ceiling or roof as a supplementary support.

For roof support installation, refer to the instructions provided with the support by the chimney manufacturer. Olympia Chimney will provide the maximum height of chimney that can be supported by the support. Make sure you respect those parameters.

4.6.2 Universal Offset Support

This support is used to support the chimney above an offset. When the chimney offset is used to pass through a wall, this support may be used on the wall to support the chimney. For offset support installation, refer to the instructions provided with the support by Olympia Chimney who provide the maximum height of chimney that can be supported by the support. Make sure you respect those parameters.

PART B - OPERATION AND MAINTENANCE

5 FUEL

The ME300 is designed to work best when fuelled with seasoned cordwood. Use solid wood or processed solid fuel fire logs only. Hardwoods are preferred to softwoods since the energy content of wood is relative to its density. Hardwoods will result in a longer burning fire and less frequent refuelling. A moisture content of 15% to 20% (seasoned) is recommended. Wood that has been cut and split and let to dry under a cover for a period of one year will usually meet those criteria. Excessively wet wood will be difficult to burn and will result in lower efficiency, increased creosoting and deposits on the glass and in the chimney. Excessively dry wood will burn well but will also have higher emissions and shorter burning time.

CAUTION: DO NOT BURN SCRAP OR GARBAGE, TREATED WOOD OR WOOD SUCH AS DRIFTWOOD FROM THE OCEAN WHICH HAS BEEN EXPOSED TO SALT OR OTHER CHEMICALS. SALT OR CHEMICALS CAN CORRODE THE FIREBOX AND CHIMNEY. DO NOT BURN LARGE AMOUNTS OF PAPER, CARDBOARD, TREE BRANCHES OR BUILDING CONSTRUCTION MATERIALS. INTENSE FIRING WITH THESE MATERIALS MAY OVERHEAT THE FIREPLACE, CAUSING DAMAGE TO THE UNIT, A HOME FIRE OR EVEN POSSIBLY IGNITING A CHIMNEY FIRE IF THE CHIMNEY IS CREOSOTED.

CAUTION: DO NOT OVER FIRE THIS HEATER OVER FIRING CAN RESULT IN A SAFETY HAZARD AND CAN PERMANENTLY DAMAGE THE FIREPLACE AND CHIMNEY.

5.1 The Use of Manufactured Logs

There are numerous types of manufactured logs sold on the market. You must be very careful with this type of product. Many brands of manufactured logs contain chemical additives. **DO NOT BURN ANY MANUFACTURED LOGS CONTAINING CHEMICAL ADDITIVES. IF YOU DO, YOU MAY OVERHEAT YOUR FIREPLACE, THEREFORE CAUSING A FIRE HAZARD AND VOIDING YOUR WARRANTY.** Manufactured logs made of 100% wood residues do not pose a threat to your fireplace. However, they must be used carefully. Manufactured logs typically release a much larger heat output over a short period of time. Therefore, you cannot place a large quantity of such logs into your fireplace. Start with one log and see how the fireplace reacts. You can increase the number of logs burned at a time to a maximum of three. Burning more than three manufactured logs at one time can overheat and damage your stove.

WARNING: DO NOT POKE OR STIR THE LOGS WHILE THEY ARE BURNING. USE ONLY FIRELOGS THAT HAVE BEEN TESTED FOR USE IN FIREPLACES (SEE ULC/ORD-C127, COMPOSITE FIRELOGS) AND PRIOR TO USE, REFER TO FIRELOG WARNINGS AND CAUTIONS MARKINGS ON PACKAGING.

6 OPERATING THE ME300 WOOD FIREPLACE

CAUTION: WHEN USING THE DECORATIVE APPLIANCE, THE FIREPLACE DAMPER MUST BE SET IN THE FULLY OPEN POSITION.

6.1 First Fires

Two things will happen as you burn your first few fires; the paint cures and the internal components of the fireplace are conditioned.

As the paint cures, some of the chemicals vaporize. The vapors are not poisonous, but they do smell bad. Fresh paint fumes can also cause false alarms in smoke detectors. So, when you first light your fireplace, be prepared by opening doors and/or windows to ventilate the house. As you burn hotter and hotter fires, more of the painted surfaces reach the curing temperature of the paint. The smell of curing paint does not disappear until you have burned one or two very hot fires.

Burn one or two small fires to begin the curing and conditioning process. Then build bigger and hotter fires until there is no longer any paint smell from the fireplace. Once the paint smell disappears, your fireplace is ready for serious heating.

6.2 Building a Fire

To start a fire, place several crumpled up balls of newspaper in the firebox behind the andiron. Place small dry pieces of kindling on top of the paper, criss-crossing the kindling so that there are air spaces in between. Open the exhaust damper fully and light the newspaper. Once the newspaper and the kindling are well ignited, you may close the glass door for a few minutes so that the firebox and chimney of your fireplace can heat up enough for optimal operation. When this heating period is done and the kindling fire is well established, you can operate the fireplace with the firescreen or the glass door depending on your preference and add cordwood as needed.

The unit will burn best with 2-3 pieces of cordwood spaced 1 to 2 inches apart and allowing air to get under the fuel. Criss-crossing or arranging the fuel so that air can get underneath, will help the fire to get started easily.

CAUTION: THE EXHAUST DAMPER AND THE AIR INTAKE CONTROL MUST BE KEPT FULLY OPEN UNTIL THE FIREPLACE HAS COOLED DOWN FOR A FEW HOURS.

WARNING: NEVER PUT CORDWOOD IN FRONT OF THE ANDIRONS.

6.3 Maintaining the Fire

Once the wood has been consumed (or partially consumed) and you have obtained a good bed of embers, you should reload the unit. In order to do so, proceed by opening the glass door or the screen door for you to have enough free space to reload safely.

Your ME300 wood fireplace will work best if a thick bed of hot embers is maintained in the bottom of the firebox and a minimum of two large pieces of seasoned fuel are added. Combustion efficiency is largely related to establishing a hot ember bed, and hot firebox temperatures. The quicker the fireplace and chimney (flue) get up to normal operating temperatures, the better. Use a poker to make an air channel in the embers below the wood. This will allow air to flow under the wood for a more efficient burn.

6.4 Air Intake Control and Exhaust Damper

The air intake control (dilution air) and exhaust damper should be in the closed position when there has not been any wood or embers in the fireplace for a few hours. This will minimize air leakage up the chimney.

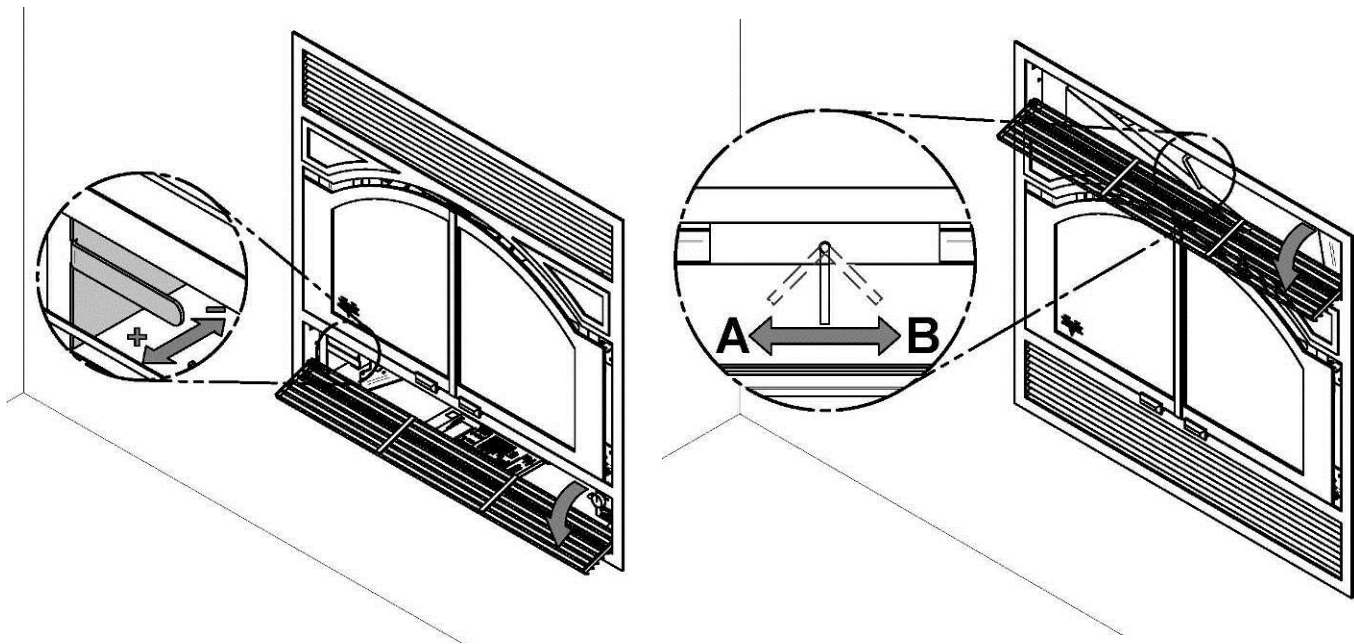

Air Intake Control

A	OPEN position
B	CLOSE position

Exhaust Damper

6.5 Smoking – Causes and Troubleshooting

Your fireplace has been designed and tested to provide smoke free operation. Occasionally, there may be a small amount of smoking upon lighting the fire, until the chimney heats up but this should not continue. If the fireplace continues to smoke it is probably for one of the following reasons:

A. Closed exhaust damper

Make sure that the exhaust damper is in the open position (see **Section 6.4: Air Intake Control and Exhaust Damper**).

B. Negative pressure in the house

As the fire burns, air goes up the chimney. This air must be replaced through leakage into the house or through the fresh air kit. When operating the ME300 wood fireplace, open a nearby window temporarily to check if there is adequate air supply replacement. If opening a window solves the problem, the house is under negative pressure.

C. Wet wood

Wet or tarred wood will smoulder and smoke instead of burning properly.

D. Dirty or blocked chimney

Check to make sure the chimney is clear and clean.

E. Chimney not long enough

The minimum system height is 15 feet (4,6 m). The chimney must extend at least 3 feet (915 mm) above its point of contact with the roof and at least 2 feet (0.6 m) higher than any roof or wall within 10 feet (3 m) of it. When installed with offsets, the minimum system height is as per Table 2. Additional height will increase draft and will decrease the tendency to smoke.

F. Poor chimney draft

With no fire, there should be sufficient draft to exhaust cigarette smoke introduced at the bottom of the throat. Chimneys installed against an outside wall without protection may generate back draft problems which will cause start-up problems. To prevent this, when you light a fire make sure you use small pieces of really dry wood and keep your glass door closed for the first 15 minutes. Reload your unit a few times with kindling before putting large pieces of cordwood.

IMPORTANT NOTES

- a. Do not burn coal. The sulphur in coal will corrode the firebox.
- b. Do not allow the wood to smoulder or burn without flame, since this will produce excessive creosote in the unit.
- c. The exhaust damper and air intake control should be always in the open position when the fireplace is in use.

7 MAINTAINING YOUR ME300 WOOD FIREPLACE

7.1 Creosote – Formation and Need for Removal

When wood is burned slowly without a flame, it produces tar and other organic vapours which combined with expelled moisture will form creosote. The creosote vapours condense in the relatively cool chimney flue of a slow-burning fire. As a result, creosote residue accumulates on the flue lining. When ignited this creosote makes an extremely hot fire. The chimney should be inspected at least twice a year during the heating season to determine if creosote build-up has occurred. When creosote has accumulated it must be removed to reduce the risk of a chimney fire.

7.2 Chimney Maintenance

Regular chimney inspection and maintenance combined with proper operation will prevent chimney fires. Keep your chimney clean. Do not allow more than 1/8" (3 mm) creosote build up in your chimney. The amount of creosote will depend on variables such as frequency of use and type of fires. We recommend that you:

- A. Initially inspect the chimney system weekly. From this, you will learn how often it will be necessary to clean your chimney.
- B. Have your chimney cleaned by a qualified chimney sweeper. If you wish to clean it yourself, we recommend using a stiff plastic or non-metallic brush. If a metal brush is used, its size should be slightly smaller than the flue to avoid damaging the chimney. Do not use a brush that will scratch the stainless steel interior of the chimney.
- C. Do not expect chemical cleaners to keep your chimney clean. The rain cap can be removed for inspection and/or cleaning of the chimney.

7.3 Dealing With a Chimney Fire

Regular chimney maintenance and inspection can prevent chimney fires. If you have a chimney fire, follow these steps:

1. Close the fireplace glass door and the exhaust damper;
2. Alert your family of the possible danger;
3. If you require assistance, alert your fire department;
4. If possible, use a dry chemical fire extinguisher, baking soda or sand to control the fire. Do not use water as it may cause a dangerous steam explosion;
5. Check outside to ensure that sparks and hot embers coming out of the chimney are not igniting the roof;
6. Do not use the fireplace again until your chimney and fireplace have been inspected by a qualified chimney sweeper or a Fire Department Inspector.

7.4 Disposal of Ashes

Ashes should be placed in a tightly covered metal container, they should be taken outside immediately. The closed container of ashes should be placed on a non-combustible floor or on the ground well away from all combustible materials pending final disposal. Ashes normally contain some live charcoal that can stay hot for several days. If the ashes are disposed of by burial in soil or otherwise locally dispersed, they should be retained in the closed container until all cinders have thoroughly cooled. Other waste should not be placed in this container.

7.5 Refractory Panel Replacement

WARNING: DO NOT USE THE FIREPLACE WITH A BROKEN OR MISSING REFRACTORY PANEL.

When replacing the refractory panels, it is possible that the insulation paper behind them is detached from the walls of firebox. You must properly position the insulation paper or get a new one from your dealer before putting the new refractory panels.

To replace the refractory panels of your ME300 fireplace, follow the steps bellow:

- 1- Using a ratchet key with a 7/16" (12 mm) socket, remove the 4 screws (B) holding up the andiron (A).

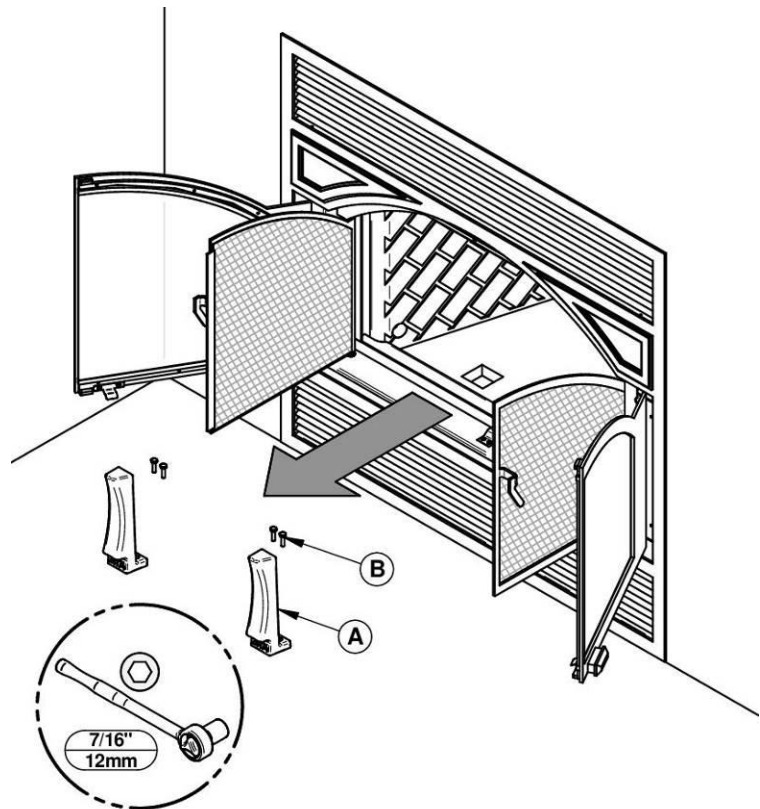

- 2- Remove the bottom refractory panel (C).

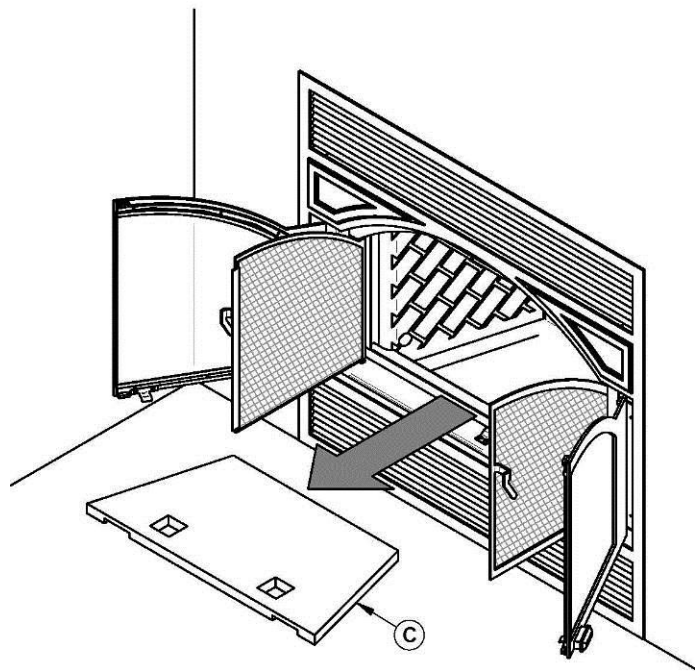

- 3- Remove the two panel holders (D) and the refractory panels (E) and (F).

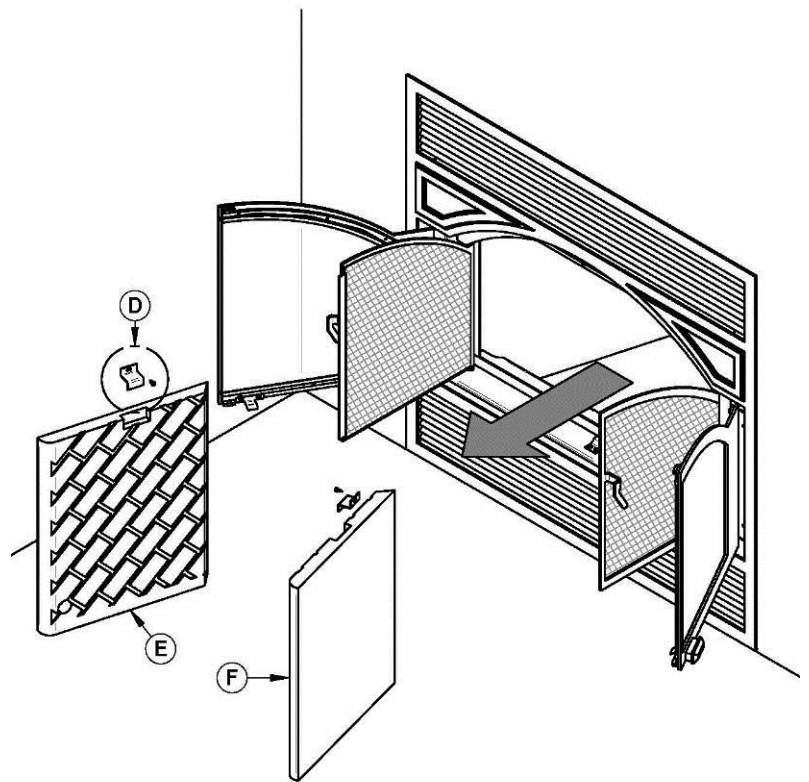

4- Remove the back refractory panel (G).

To install new refractory panel, follow the above steps in reverse.

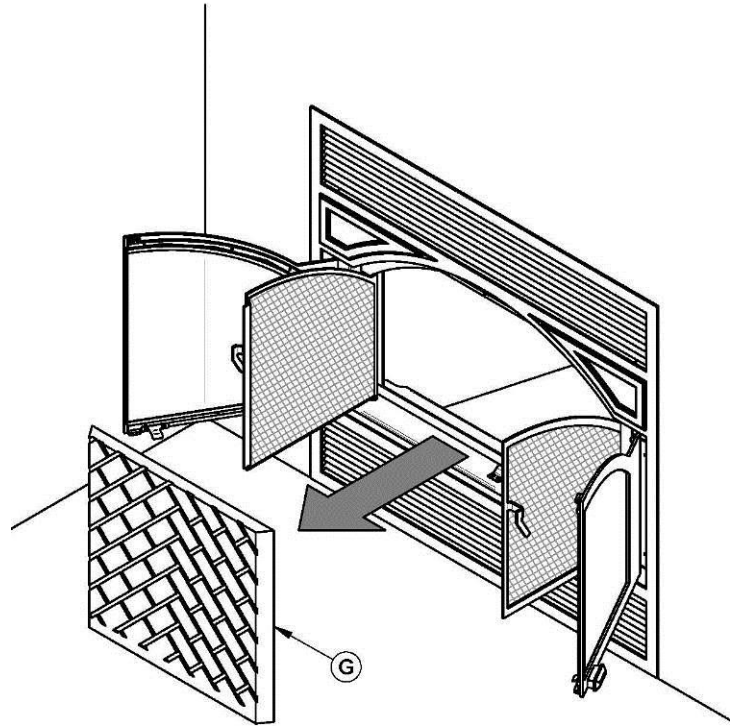

7.6 Replacing the Glass and/or the Glass Gasket

To replace the glass, remove the glass retaining screws (A) and the 4 metal frames (B) that hold the glass (C) to the door frame (D). Lift out the glass (C). Do the same for the other door. This is a good time to clean the glass thoroughly. To install the new glass, follow the above steps in reverse order.

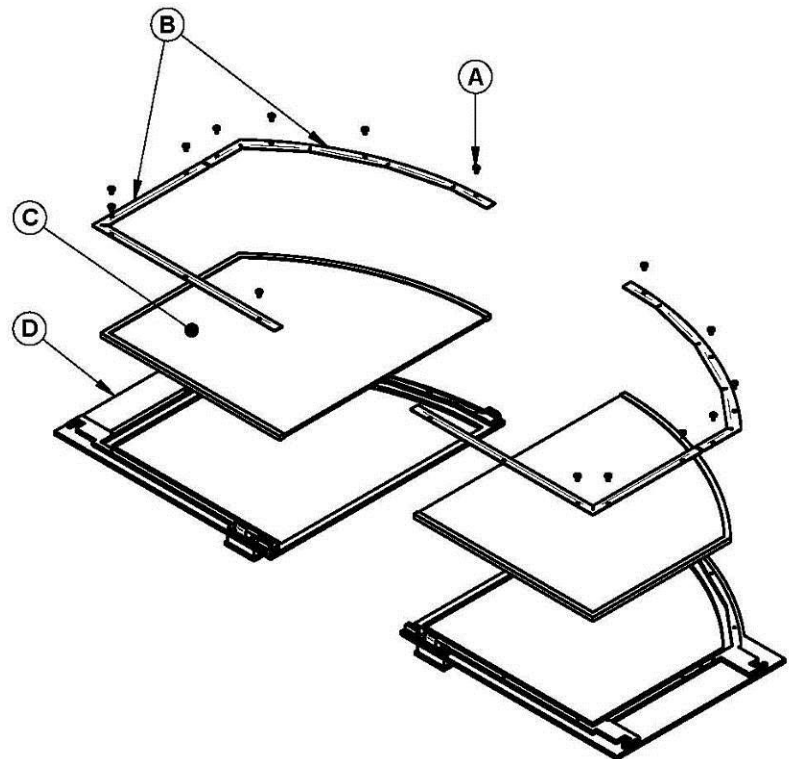

It might be necessary to replace the glass gasket from time to time. The gasket is flat, adhesive-backed, woven fibreglass. Remove the glass retaining screws (A) and the 4 metal frames (B) that hold the glass (C) to the door frame (D). Lift out the glass (C) and pull off the old gasket. Do the same for the other door. This is a good time to clean the glass thoroughly.

The gasket must be centred on the edge of the glass. To do this easily, peel back a section of the paper covering the adhesive and place the gasket on a table with the adhesive side up. Stick the end of the gasket to the middle of one edge, then press the edge of the glass down onto the gasket, taking care that it is perfectly centred on the gasket. Peel off more of the backing and rotate the glass and press the next section onto the gasket. Do not stretch the gasket as you place it. Do not apply the gasket on the center edge of the glass. Now pinch the gasket to the glass in a U shape, all around the glass. Reinstall the glass, being careful to centre the glass carefully in the door. Do not over-tighten the screws. Note that the two main causes of broken door glass are uneven placement in the door and over-tightening of retaining screws.

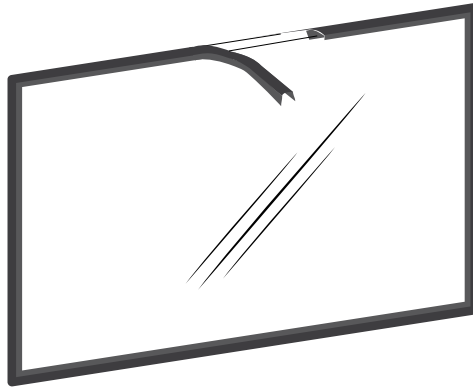

Location	Length	Dimension
Around each glass	48 5/8" (124 cm)	"U" shaped

Both glasses used in the ME300 are 5 mm thick of dimension: 18" x 15 5/16" and tested to reach temperatures up to 1,400 °F. If the glass breaks, it must be replaced with one having the same specification. Contact your Ventis dealer to obtain a genuine replacement part (see "replacement parts", in appendix to get the proper part number).

WARNING: DO NOT ABUSE THE GLASS DOOR BY SLAMMING IT AGAINST THE FIREPLACE.

WARNING: DO NOT OPERATE THE FIREPLACE WITH A CRACKED OR BROKEN GLASS.

WARNING: TEMPERED GLASS OR ORDINARY GLASS WILL NOT WITHSTAND THE HIGH TEMPERATURES OF THE ME300.

7.7 Plated Finish Maintenance

If your appliance has a plated finish, use a metal polish and a soft cloth to clean it. Do not use abrasives such as steel wool, steel pads or an abrasive cleaner for they may scratch the finish.

7.8 Glass Care – Cleaning

To clean the glass, there are a number of specially designed cleaners. Your authorized Ventis dealer can recommend a suitable cleaner which is available in your area. Regular household glass cleaners will not clean creosote and they usually contain ammonia that may stain the glass permanently.

WARNING: ONLY WASH THE GLASS WHEN IT'S COLD.

WARNING: DO NOT USE ABRASIVES SUCH AS STEEL PADS, STEEL WOOL OR OVEN CLEANER AS THEY WILL SCRATCH THE GLASS.

7.9 Blower Maintenance or Replacement

1. Open the bottom louver (A).

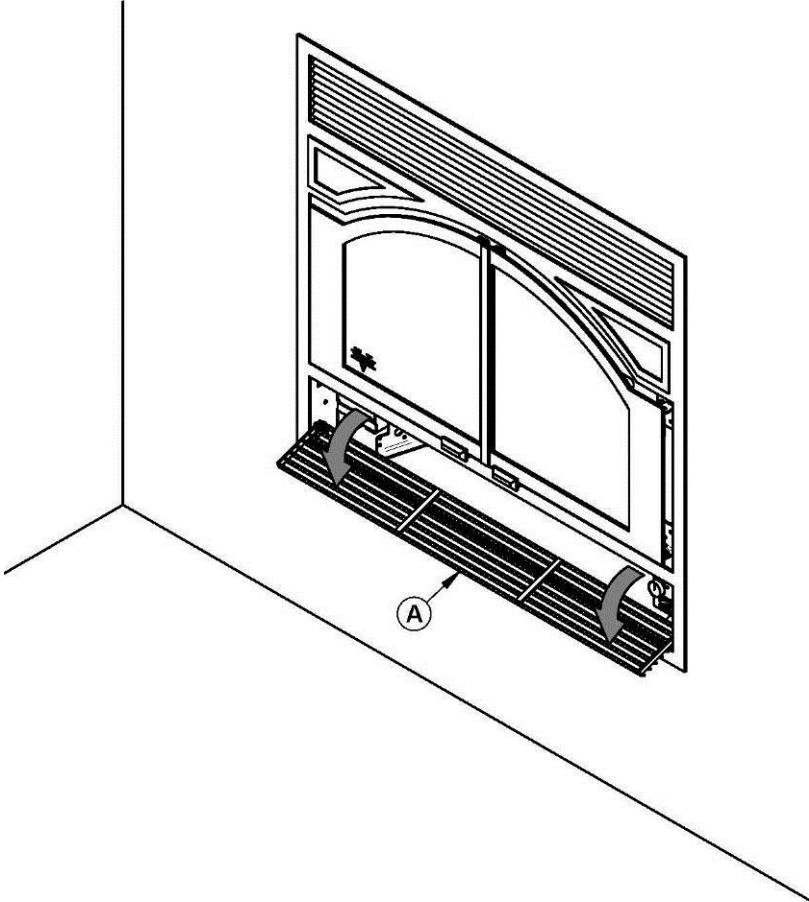

2. Cut the Tie wrap (B)

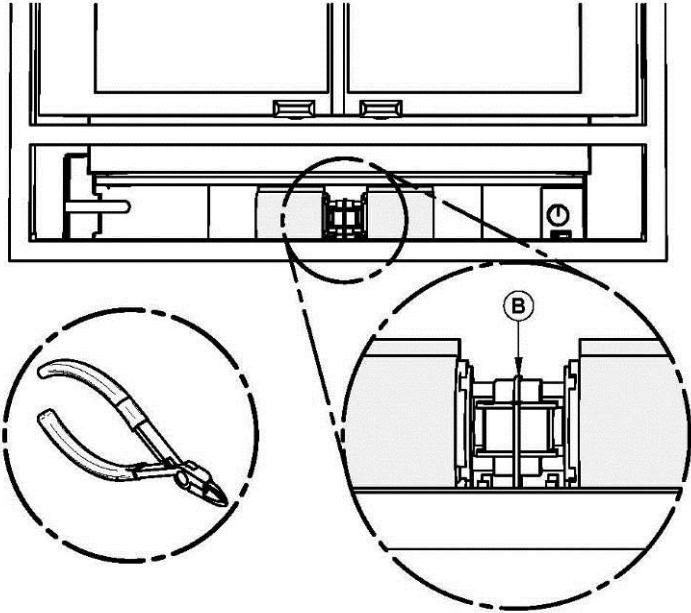

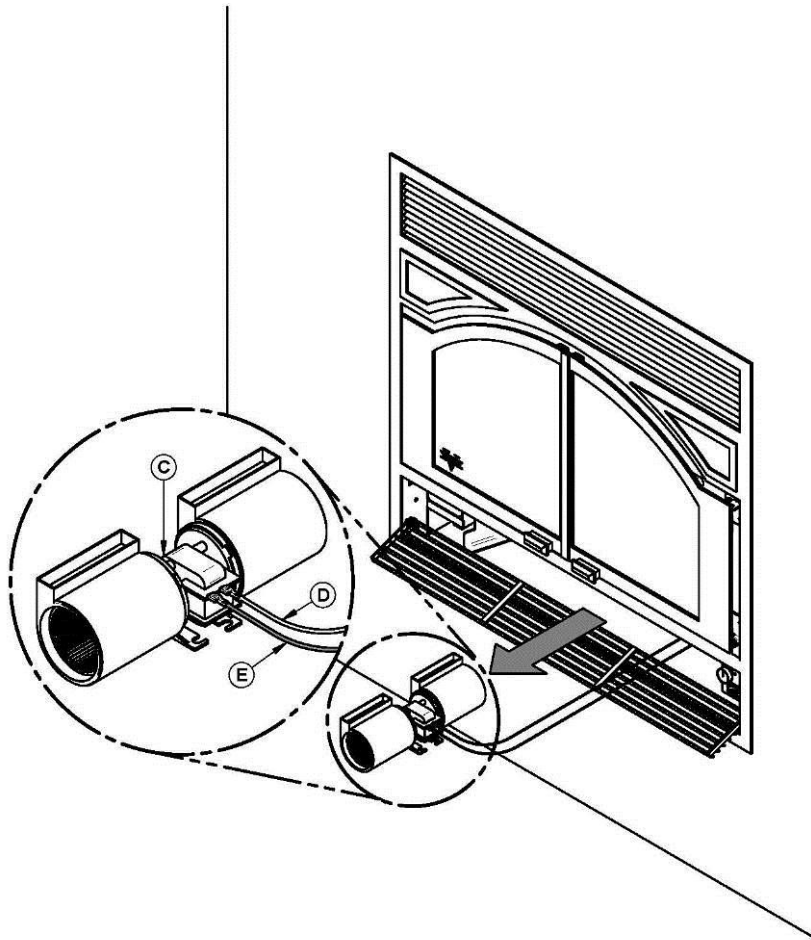

3. Lift the blower (C) located under the firebox towards the back. Turn 90° to pull out.
4. Unplug the blower's electric wires (D) and (E).

Repeat the steps in reverse order to reinstall the fan.

Blower connection

Have the wiring installed by a qualified electrician. Connect the wires from the power outlet to the terminal block, making sure that the white wire matches the white wire on the terminal. Connect the black wire with the black wire of the terminal block. The ground (green or skinned wire) must be attached to the fireplace metal frame.

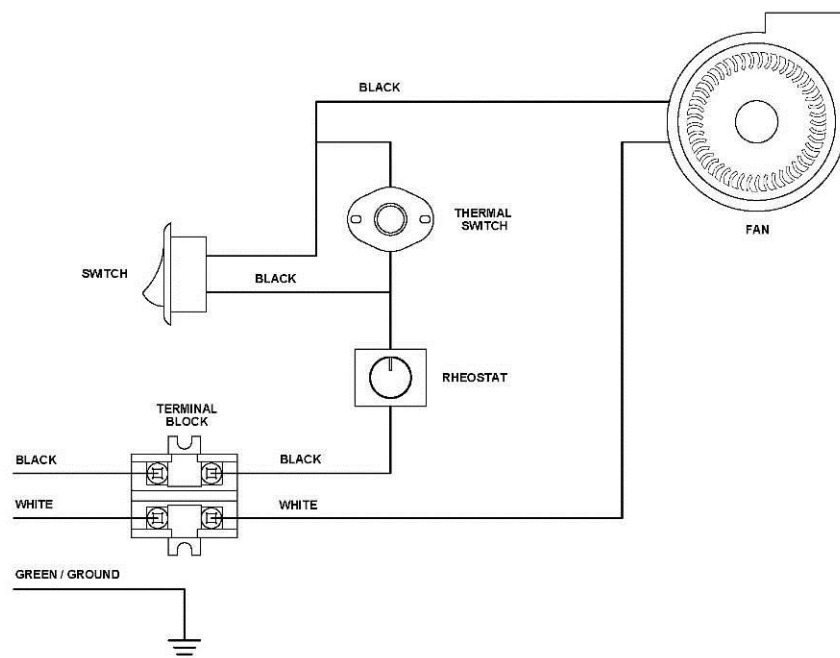

APPENDIX 1: OPTIONAL HEAT DISTRIBUTION SYSTEMS INSTALLATION (AC01375, AC01376 OR AC01340)

Different heat distribution systems can be installed with the ME300:

- Hot air gravity distribution kit - Traditional style (AC01375)
- Hot air gravity distribution kit - Modern style (AC01376)
- Forced air distribution kit (AC01340)
- **Hot air gravity distribution kit - Traditional style (AC01375)**

The kit includes:

- 2 x hot air outlets (grilles (A) and frames (B));
- 2 x 90° elbows (C);
- 6 x steel brackets (D) with fastening screws (E) and self-tapping screws (F)

Parts not included in the kit:

- 2 x 8" rigid ducting (G)

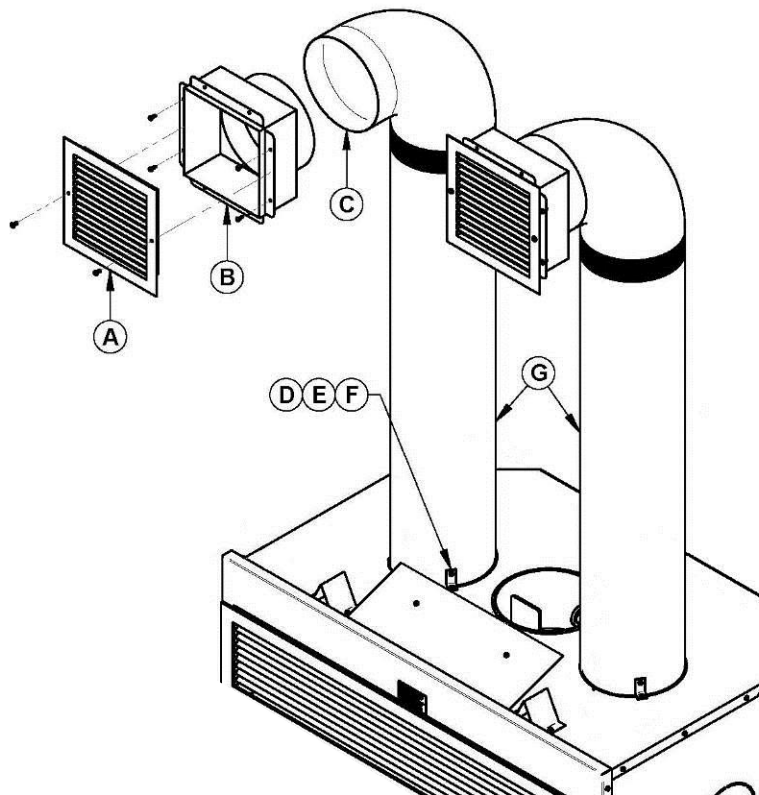

DIMENSIONS OF HOT AIR OUTLET FRAME WITH ELBOW

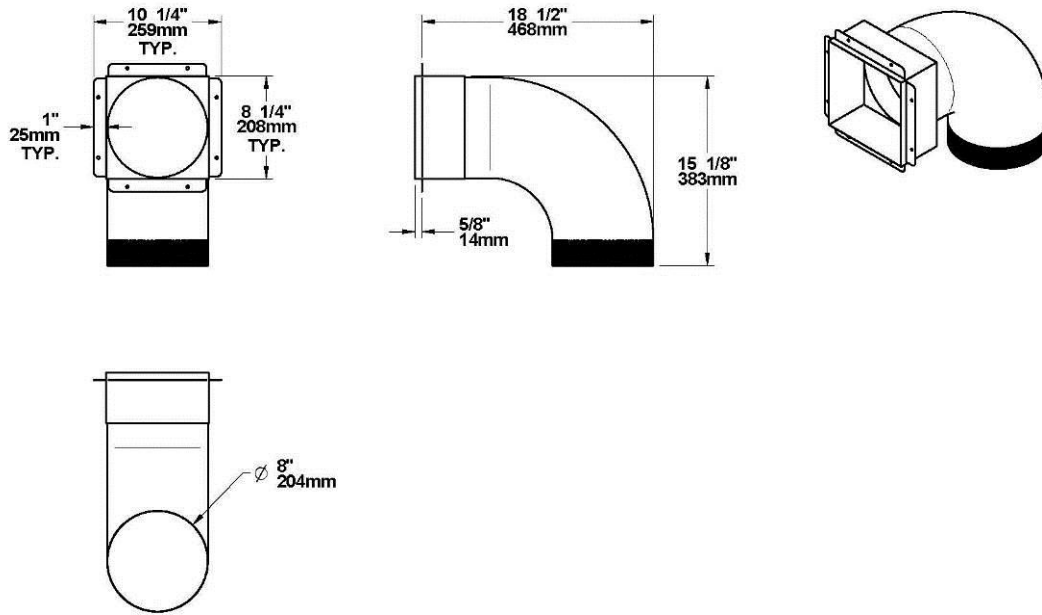

DIMENSIONS OF HOT AIR OUTLET DECORATIVE GRILLE WITH ELBOW

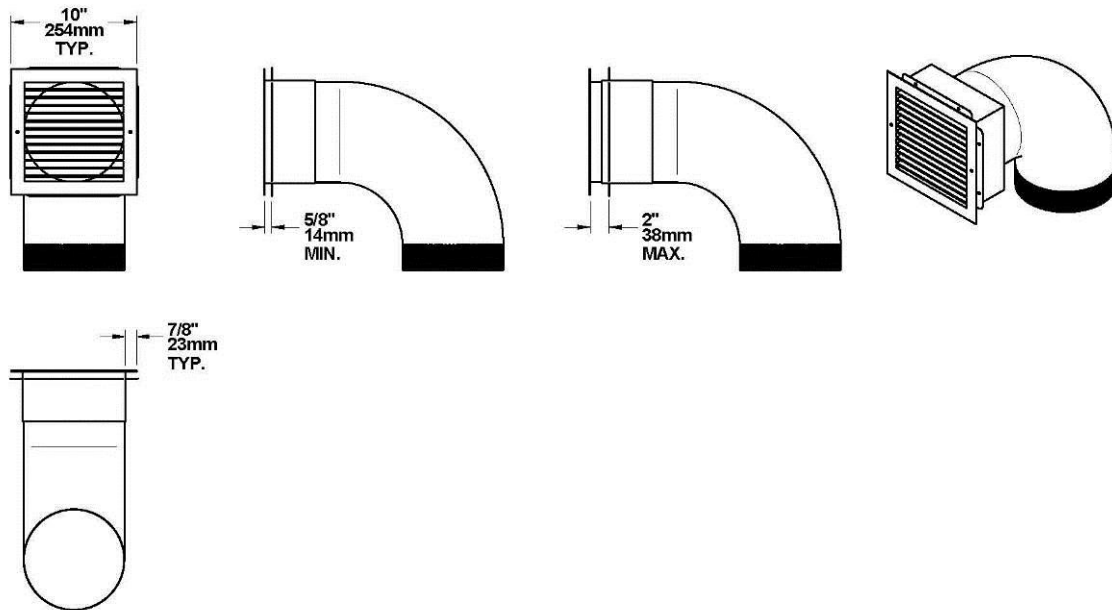

The safety rules and installation procedures for both AC01375 and AC01376 hot air gravity distribution kits are the following:

Minimum height*	68" (1.7 m)
Minimum distance from ceiling:	12" (30 cm)
Maximum length	10' (3m)

*The minimum height of the hot air ducting must be measured from the floor to the top of the hot air grilles.

The hot air grilles can be installed in the same room as the fireplace, or one or both of the grilles can be installed in adjacent or upper rooms. Installing the ducts at different elevations will tend to exhaust more heat out of the higher grilles.

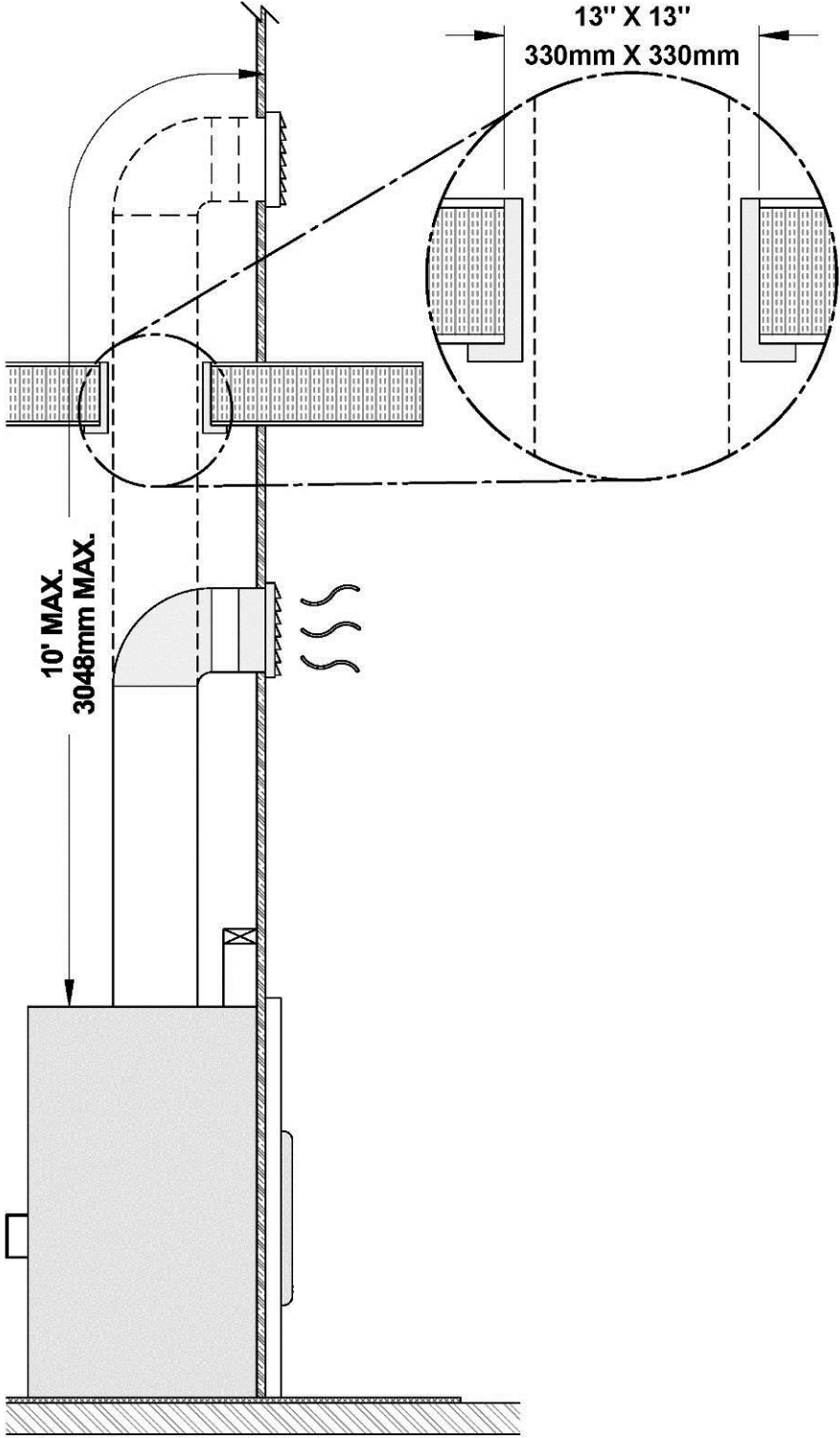

Hot air gravity distribution kit - Modern style (AC01376)

L'ensemble comprend :

- Decorative plate (A)
- Adjustable frame (B)
- Heat distribution box (C)
- 6 x steel brackets (D) with fastening screws (E) and self-tapping screws (F)
- 2 x Finishing cap assemblies (H) AND (J)
- 2 x Fastening screws (I)

Parts not included in the kit:

- 2 x 8" rigid ducting (G)

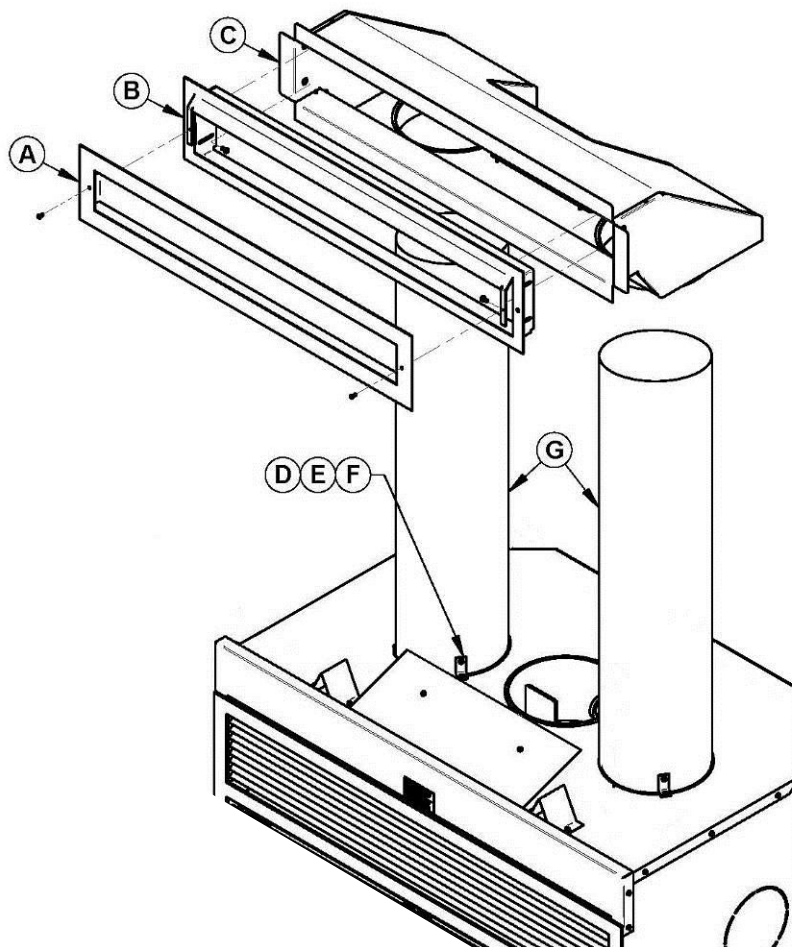

DIMENSIONS OF HEAT DISTRIBUTION BOX:

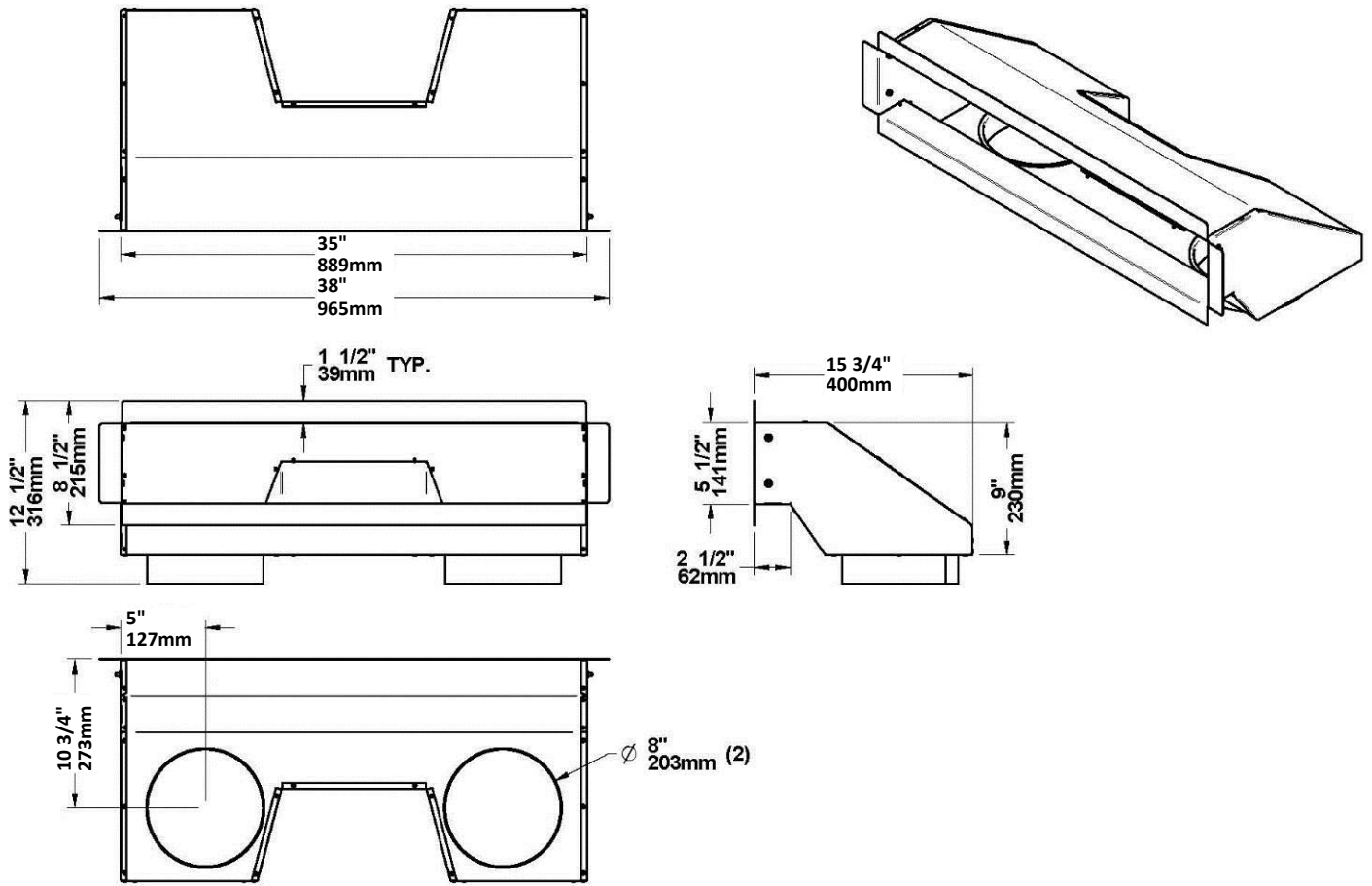

DIMENSIONS OF ADJUSTABLE DECORATIVE PLATE:

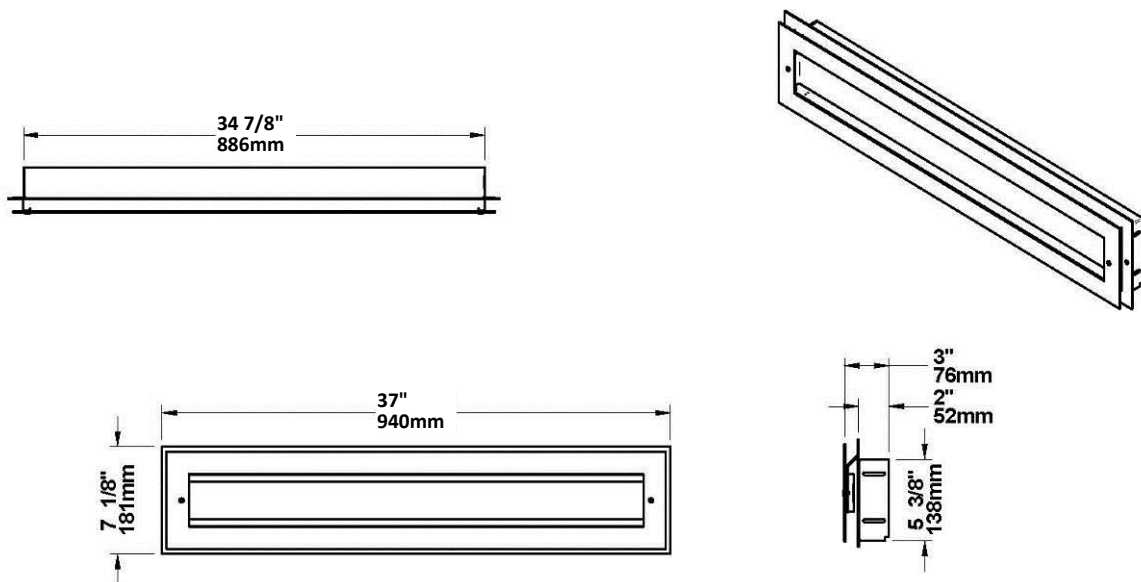

DIMENSIONS OF ASSEMBLED HEAT DISTRIBUTION BOX AND ADJUSTABLE DECORATIVE PLATE:

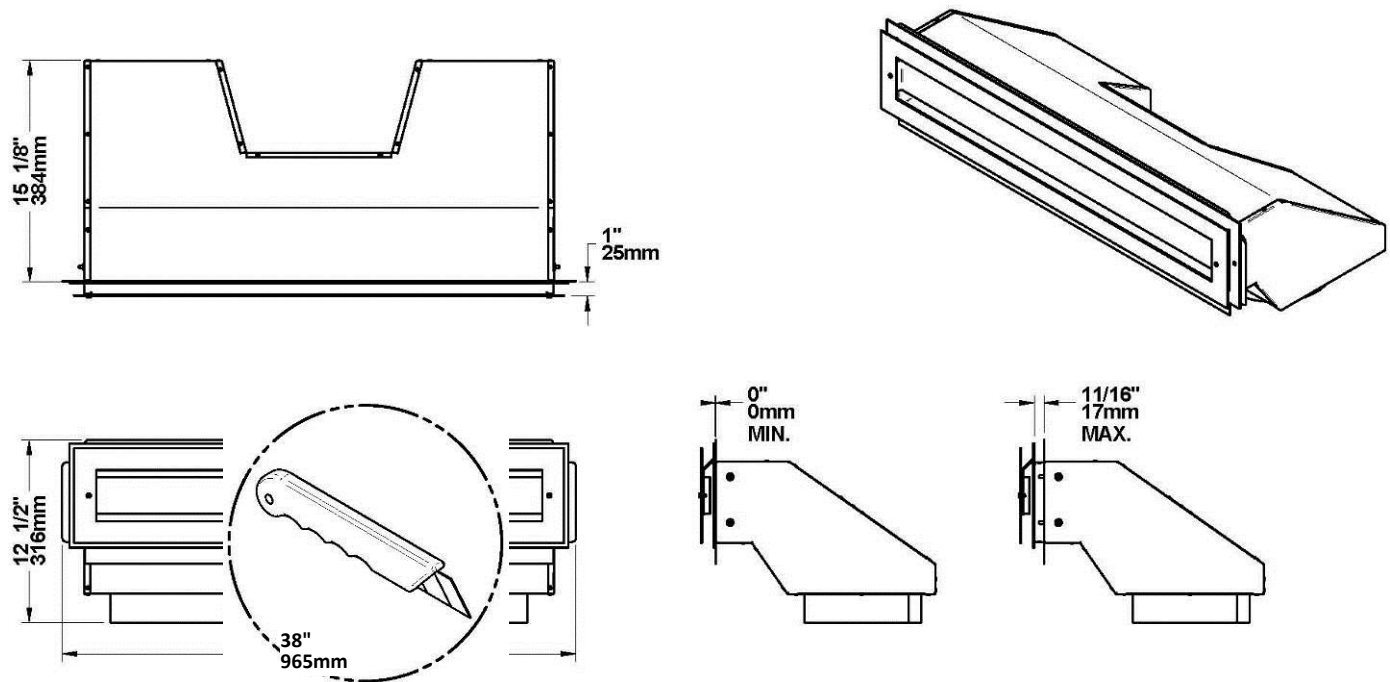

The hot air gravity distribution kit must be installed respecting the following:

1. **It is recommended to wear gloves to perform this procedure.** For either AC01375 or AC01376, remove the plates closing up the 8" dia. holes on top of the fireplace. Then, cut and remove the insulation in order to obtain two 8" dia. openings. Then, remove the plates closing up the 8" dia. holes inside the fireplace.

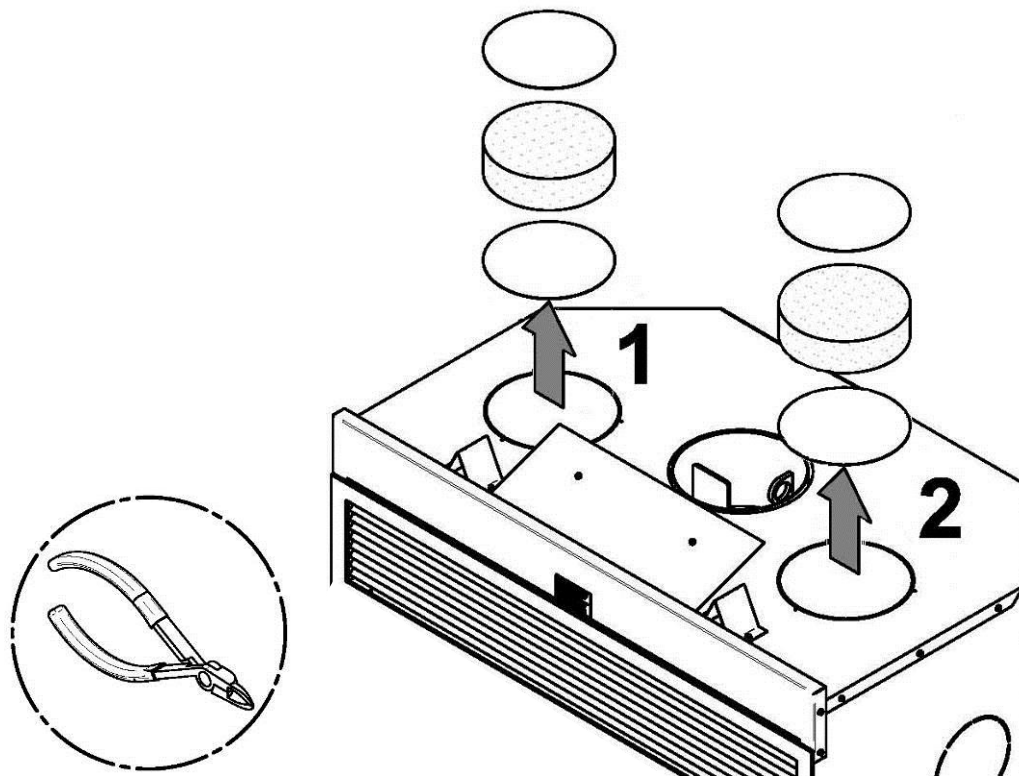

For AC01375 installation:

1. Secure the 6 steel brackets (D) with 6 screws provided (E) on top of the fireplace (3 for each ducting). Insert the ducting (G) (not provided) into each opening and secure it in place using the steel brackets (D) installed previously with 6 other self-tapping screws provided (F).
2. Secure the ducting (G) to the 90° elbows (C) with self-tapping screws (3 per elbow). Insert the hot air outlets (B) in the elbow (C). Set hot air outlets frames behind the non-combustible material and secure to the wall with screws. Secure hot air outlets (B) to the elbows (C) with 3 self-tapping screws each. Secure the hot air outlets grilles (A) to the frames with screws.

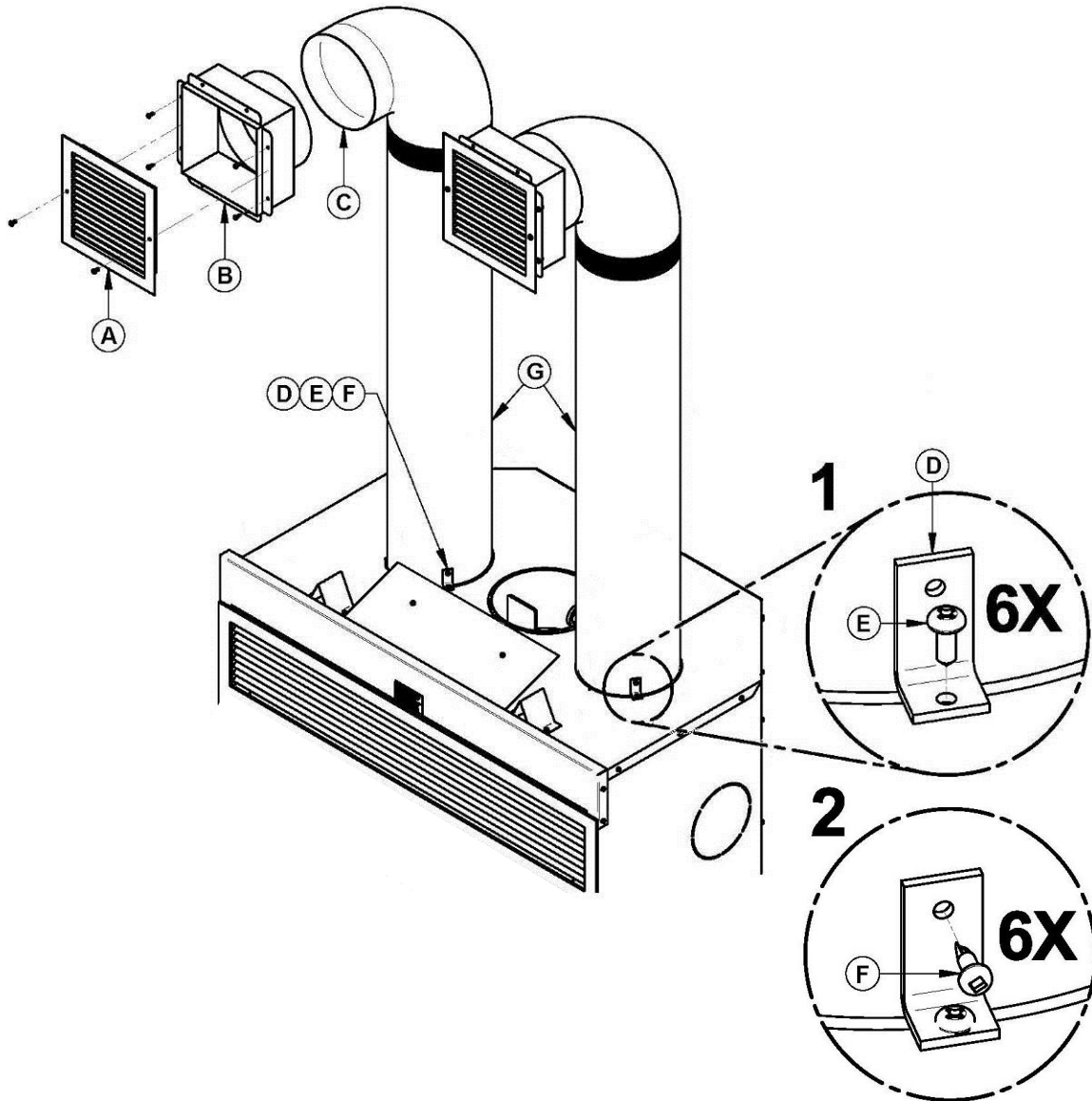

3. Maintain at least a 2" (50 mm) clearance between the ducts and the firestop; the required hole size for the hot air grilles (outlet) is 8¼" × 8¼" (210 mm × 210 mm).
4. The maximum number of elbows in a run of duct is two.
5. Maintain at least 10" (254 mm) clearance from the outlet grille framing to a combustible ceiling, side wall or mantel.
6. When passing through a combustible wall or floor, a firestop must be installed at the wall or floor penetration. The hole size must be in accordance with the duct manufacturer's instructions.

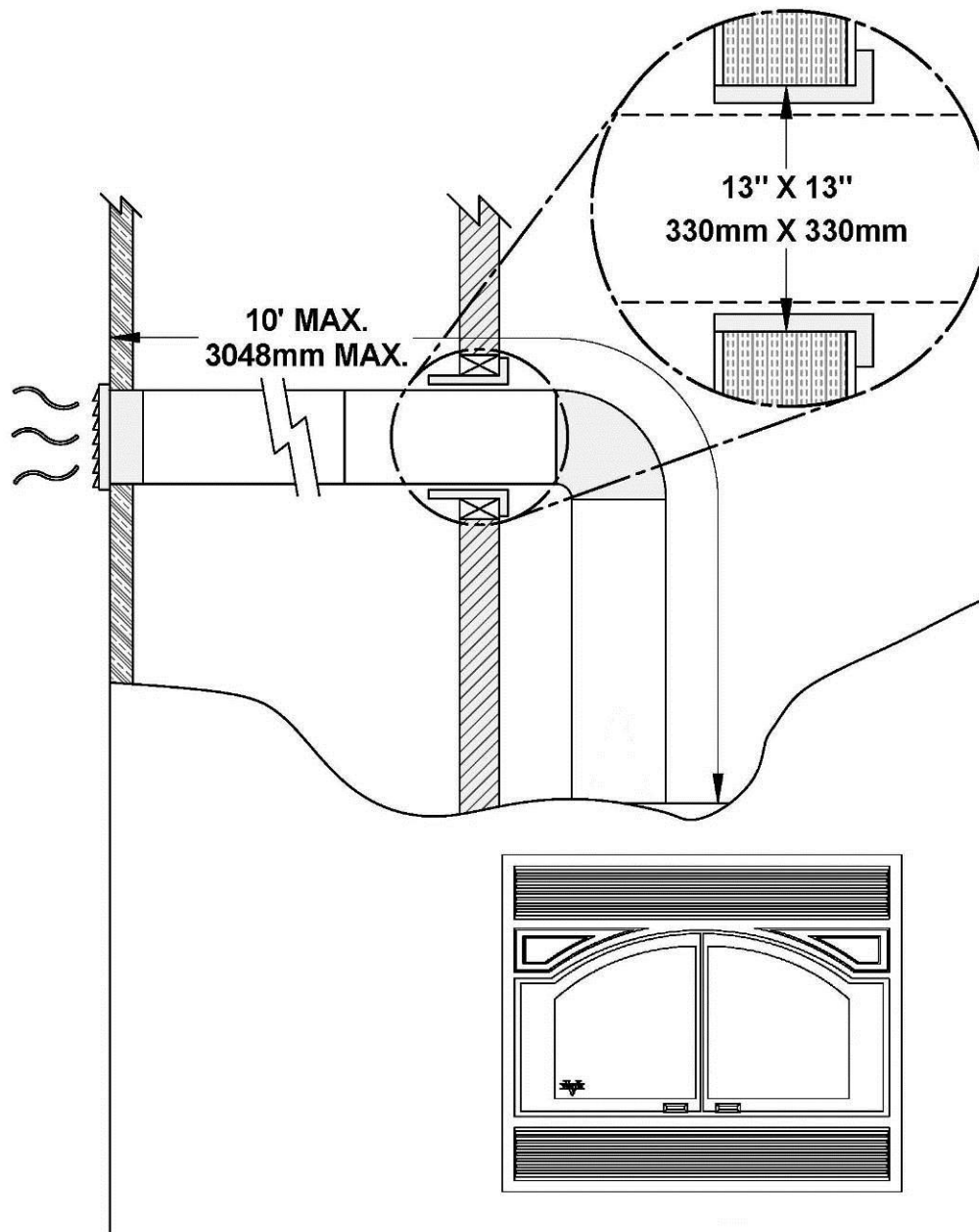

7. Do not connect the hot air ducts to a central heating system. Malfunction of the heating system's fan will cause the fireplace to overheat.
8. Do not use insulated flexible ducts as they may overheat.
9. Do not use tees or any other components than the ones specifically listed here.
10. All ducts must extend upwards or horizontally. **Never route the ducting downwards.**
11. The hot air outlet grilles must be installed with the louvers pointing downwards in order to prevent overheating adjacent ceilings.
12. Always install the two outlet grilles when using the hot air distribution kit and blocking the upper louver of the fireplace.

For AC01376 installation:

1. Secure the 6 steel brackets (D) with 6 screws provided (E) on top of the fireplace (3 for each ducting). Insert the ducting (G) (not provided) into each opening and secure it in place using the steel brackets (D) installed previously with 6 other self-tapping screws provided (F).
2. Secure the ducting (G) to the heat distribution box (C) with self-tapping screws (3 per ducting). Insert the adjustable frame (B) in the heat distribution box, press it against the non-combustible finishing material and secure with 4 screws into the heat distribution box. Set the decorative plate (A) to the adjustable frame (B) with two fastening screws (I) and finishing cap assemblies (H) and (J) provided in the kit.

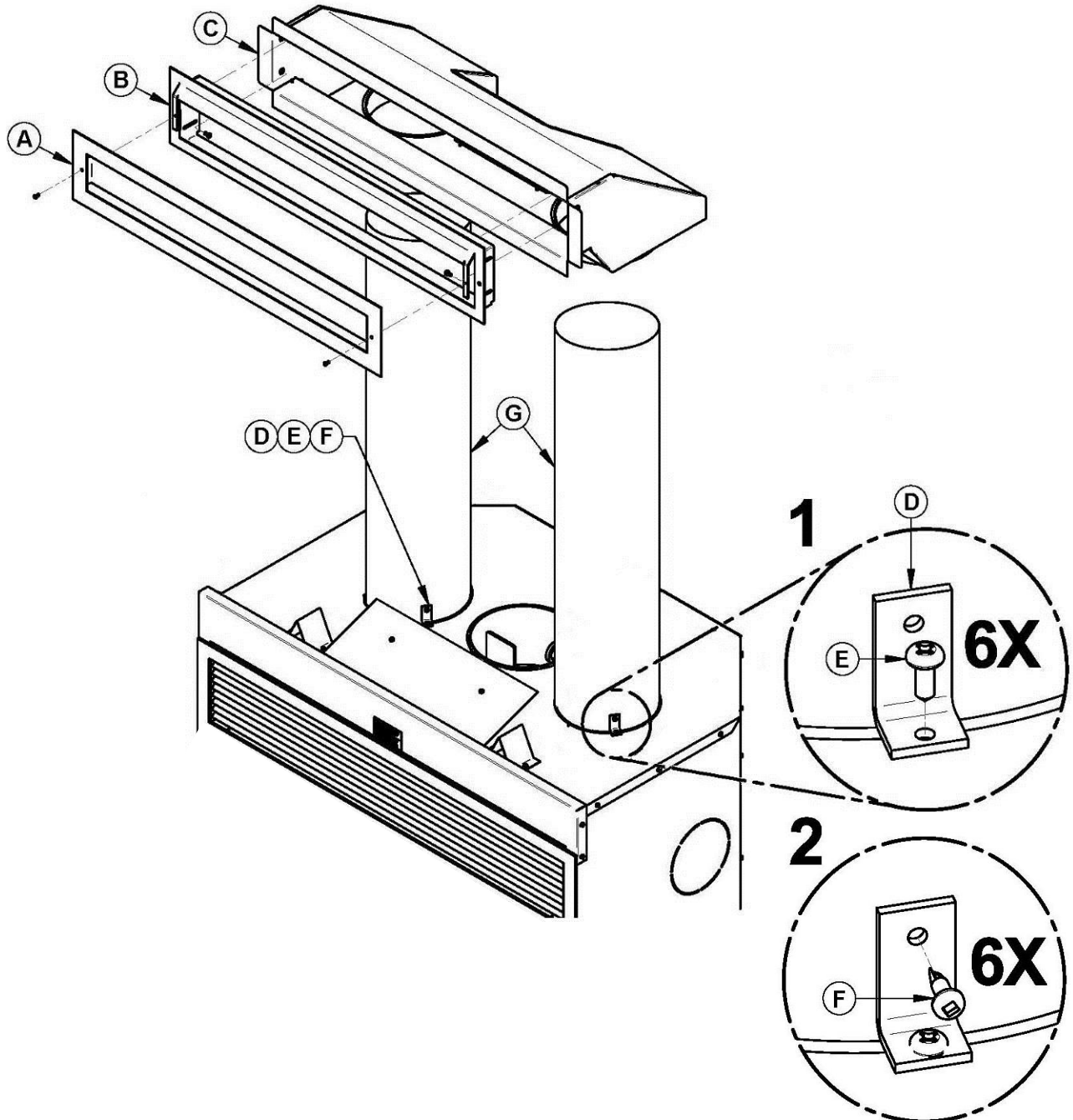

Forced Air Distribution Kit* (AC01340)

It is possible to connect a forced air distribution kit (AC01340) on the back or on either side of the HE250. This kit allows distributing heat to another room up to 50 feet (15 m) of the fireplace. The insulated flexible pipe (not included in the kit) must be HVAC type pipe and must comply with ULC S110 and/or UL 181, Class 0 or Class 1 Standards and must withstand temperatures up to 250 °F.

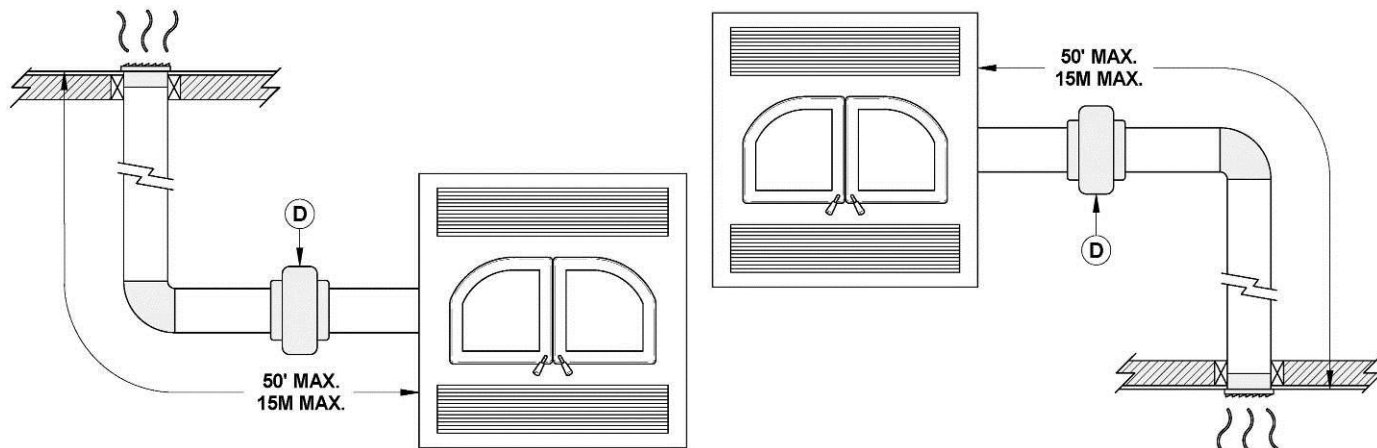

*The EPA standard states that it is necessary to perform certification testing with any ventilation that is likely to alter the units' performance. For this reason, SBI has tested the effects of the forced air kit on the emissions of fine particles. Due to the design of our appliance and more specifically to the temperature sensor that is installed to control stops and starts, the forced air kit does not affect the emission results. In fact, this option promotes the recovery of excess heat to later redistribute it to other rooms. During our testing, it was noted that the convection blowers underneath the firebox had more of an effect on the fine particles emission due to the air being directed onto the firebox thus cooling the unit. However, this appliance has already been tested for emission with one or more convection blowers. In conclusion, we have satisfied the environmental requirements efficiently.

For the complete installation procedure, see the installation manual provided with the kit. You can also download this manual at www.occanada.com

APPENDIX 2: EXPLODED DIAGRAM AND PARTS LIST

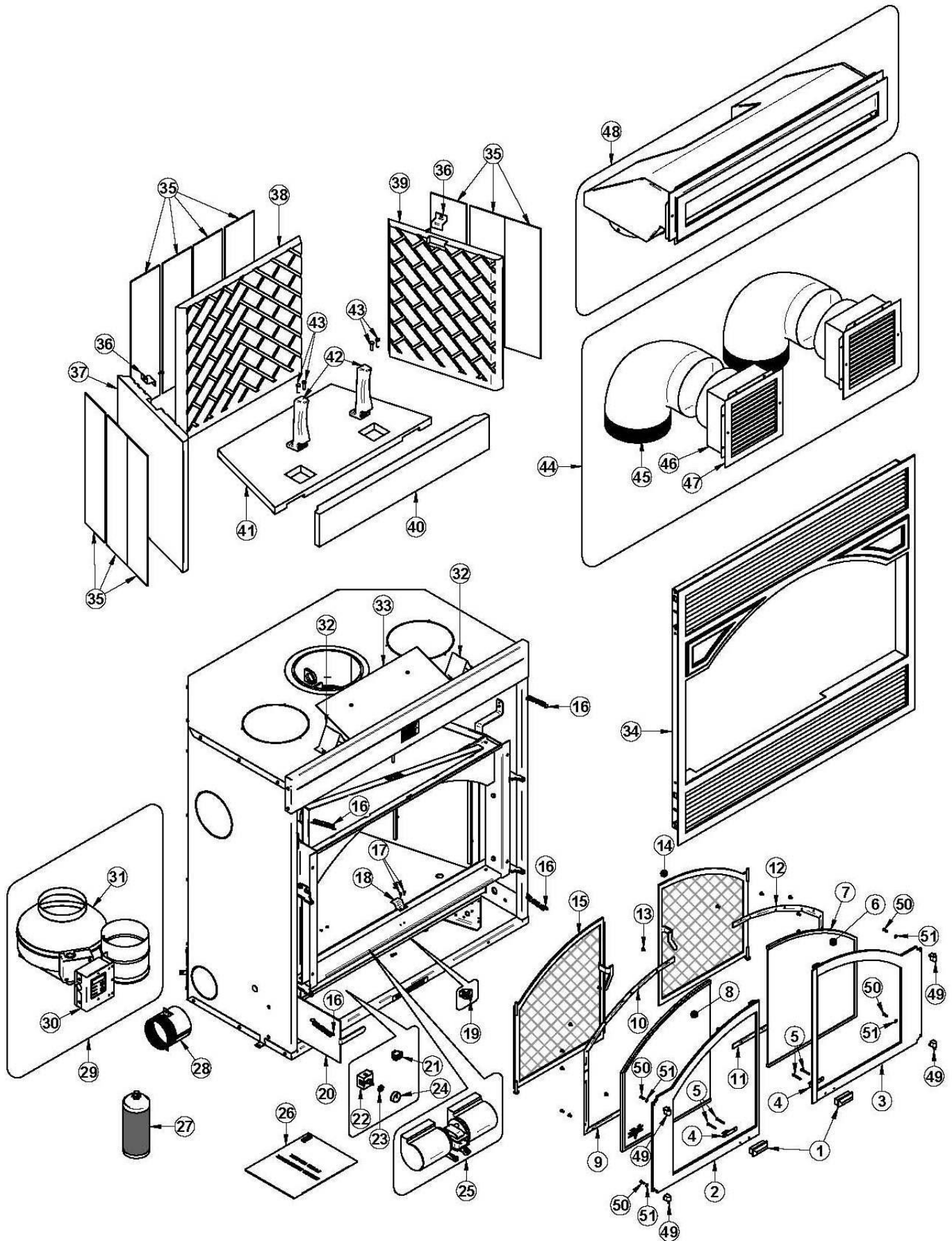

IMPORTANT: THIS IS DATED INFORMATION. When requesting service or replacement parts for your stove, please provide the model number and the serial number. We reserve the right to change parts due to technology upgrade or availability. Contact an authorized dealer to obtain any of these parts. Never use substitute materials. Use of non-approved parts can result in poor performance and safety hazards.

#	Item	Description	Qty
1	30564	BLACK WOODEN DOOR HANDLE	2
2	SE59760	LEFT DOOR FRAME ASSEMBLY	1
3	SE59761	RIGHT DOOR FRAME ASSEMBLY	1
4	PL59917	DOOR RETAINER	2
5	30244	WOOD SCREW #8 X 3/4" PAN HEAD	4
6	SE59882	REPLACEMENT GLASS WITH GASKET 15 1/8" X 18 1/32"	1
7	AC06400	BLACK SELF-ADHESIVE GLASS GASKET KIT (6')	2
8	SE59881	REPLACEMENT GLASS WITH GASKET 15 1/8" X 18 1/32"	2
9	PL59913	BOTTOM LEFT GLASS RETAINER	1
10	PL59939	TOP LEFT GLASS RETAINER	1
11	PL59912	BOTTOM RIGHT GLASS RETAINER	1
12	PL59940	TOP RIGHT GLASS RETAINER	1
13	30124	SCREW #8 - 32 X 5/16" TRUSS QUADREX ZINC	16
14	SE59876	RIGHT FIRESCREEN DOOR	1
15	SE59877	LEFT FIRESCREEN DOOR	1
16	30472	SPRING 1/2" OUTSIDE DIA. X 3" LONG	4
17	30158	BLACK METAL SCREW #8 X 1/2" PAN QUADREX TYPE "A"	2
18	PL59788	SCREEN DOOR CLIP	1
19	VA1150	THERMODISC F120-10F	1
20	PL59935	AIR CONTROL LEVER	1
21	44091	ROCKER SWITCH 2 POSITION MSR-8	1
22	44080	RHEOSTAT WITH NUT	1
23	44087	RHEOSTAT NUT	1
24	44085	RHEOSTAT KNOB	1
25	44122	DOUBLE CAGE BLOWER 176 CFM	1
26	SE45722	OWNER MANUAL VB00001 FIREPLACE	1
27	AC05959	METALLIC BLACK STOVE PAINT-342G AEROSOL	1
28	PL59765	4" ADAPTER FOR FRESH AIR INTAKE KIT	1
29	AC01340	FORCED AIR DISTRIBUTION KIT	1
30	44125	FORCED AIR DISTRIBUTION KIT PC CARD	1
31	44142	BLOWER 6" 300 CFM	1
32	PL60266	TOP STAND-OFF	2
33	PL59821	TOP HEAT SHEILD	1
34	VBA1520	TRADITIONAL STYLE FACEPLATE - METALLIC BLACK	1
35	21394	REFRACTORY PANEL ISOLATION	10
36	PL59856	REFRACTORY PANEL RETAINER	2
37	22166	LEFT REFRACTORY PANEL	1
38	22165	BACK REFRACTORY PANEL	1
39	22167	RIGHT REFRACTORY PANEL	1

#	Item	Description	Qty
40	22161	FRONT REFRACTORY PANEL	1
41	22160	BOTTOM REFRACTORY PANEL	1
42	VA7070	CAST IRON ANDIRON	2
43	30109	BOLT HEX 1/4 - 20 X 1"	4
44	AC01375	HOT AIR GRAVITY DISTRIBUTION KIT - TRADITIONAL STYLE	1
45	49066	90° GALVANISED ELBOW X 8" 26Ga.	2
46	30640	GAKLVANISED BOX FOR HOT AIR GRAVITY DISTRIBUTION KIT 8"	2
47	30540	HOT AIR GRAVITY DISTRIBUTION KIT GRILL	2
48	AC01376	HOT AIR GRAVITY DISTRIBUTION KIT - MODERN STYLE	1
49	30566	DOOR HINGE	4
50	30022	MECHANICAL SCREW 10-32 X ½ FLAT HEAD	4
51	30192	STAR RING #10	4

VENTIS LIMITED LIFETIME WARRANTY

The warranty of the manufacturer extends only to the original retail purchaser and is not transferable. This warranty covers brand new products only, which have not been altered, modified nor repaired since shipment from factory. Proof of purchase (dated bill of sale), model name and serial number must be supplied when making any warranty claim to your VENTIS dealer.

This warranty applies to normal residential use only. Damages caused by misuse, abuse, improper installation, lack of maintenance, over firing, negligence or accident during transportation, power failures, downdrafts, venting problems or under-estimated heating area are not covered by this warranty. The recommended heated area for a given appliance is defined by the manufacturer as its capacity to maintain a minimum acceptable temperature in the designated area in case of a power failure.

This warranty does not cover any scratch, corrosion, distortion, or discoloration. Any defect or damage caused by the use of unauthorized or other than original parts voids this warranty. An authorized qualified technician must perform the installation in accordance with the instructions supplied with this product and all local and national building codes. Any service call related to an improper installation is not covered by this warranty.

The manufacturer may require that defective products be returned or that digital pictures be provided to support the claim. Returned products are to be shipped prepaid to the manufacturer for investigation. Transportation fees to ship the product back to the purchaser will be paid by the manufacturer. Repair work covered by the warranty, executed at the purchaser's domicile by an authorized qualified technician requires the prior approval of the manufacturer. All parts and labour costs covered by this warranty are limited according to the table below.

The manufacturer, at its discretion, may decide to repair or replace any part or unit after inspection and investigation of the defect. The manufacturer may, at its discretion, fully discharge all obligations with respect to this warranty by refunding the wholesale price of any warranted but defective parts. The manufacturer shall, in no event, be responsible for any uncommon, indirect, consequential damages of any nature, which are in excess of the original purchase price of the product. A one-time replacement limit applies to all parts benefiting from lifetime coverage. This warranty applies to products purchased after March 1st, 2015.

DESCRIPTION	WARRANTY APPLICATION	
	PARTS	LABOUR
Combustion chamber (welds only), castings and convector air-mate.	Lifetime	4 years
Plating* (defective manufacture) – subject to limitations above and ceramic glass (thermal breakage only*).	Lifetime	N/A
Stainless steel firebox components, C-Cast baffle*, vermiculite baffle* and secondary air tubes*, glass retainers and handle assembly.	5 years	3 years
Surrounds and heat shields, ash drawer, steel legs, pedestal and trim (aluminum extrusions).	5 years	N/A
Carbon steel firebox components.	3 years	2 years
Blowers, heat sensors, switches, rheostat, wiring and electronics.	2 years	1 year
Paint (peeling), gaskets, insulations, firebricks and ceramic fibre blankets.	1 year	N/A

***Pictures required**

Labour cost and repair work to the account of the manufacturer are based on a predetermined rate schedule and must not exceed the wholesale price of the replacement part.

Shall your unit or a components be defective, contact immediately your **VENTIS** dealer. To accelerate processing of your warranty claim, make sure to have on hand the following information when calling:

- Your name, address and telephone number;
- Bill of sale and dealer's name;
- Installation configuration;
- Serial number and model name as indicated on the nameplate fixed to the back of your unit;
- Nature of the defect and any relevant information.

Before shipping your unit or defective component to our plant, you must obtain an Authorization Number from your **VENTIS** dealer. Any merchandise shipped to our plant without authorization will be refused automatically and returned to sender.